

(12) **United States Patent**
Murray et al.

(10) **Patent No.:** **US 10,272,544 B1**
(45) **Date of Patent:** **Apr. 30, 2019**

(54) **METHODS AND APPARATUS FOR CLAMPING TOOLS**

(71) Applicant: **Exceptional IP Holdings, LLC**, Apex, NC (US)

(72) Inventors: **Scott A. Murray**, Lenexa, KS (US);
Sun Xiao Wei, YongKang (CN)

(73) Assignee: **Exceptional IP Holdings, LLC**

(*) Notice: Subject to any disclaimer, the term of this patent is extended or adjusted under 35 U.S.C. 154(b) by 382 days.

(21) Appl. No.: **15/250,798**

(22) Filed: **Aug. 29, 2016**

Related U.S. Application Data

(63) Continuation of application No. 14/171,731, filed on Feb. 3, 2014, now Pat. No. 9,427,848, which is a continuation of application No. 13/037,204, filed on Feb. 28, 2011, now Pat. No. 8,641,024, which is a continuation of application No. 11/383,201, filed on May 13, 2006, now Pat. No. 7,896,323, which is a continuation of application No. 10/965,958, filed on Oct. 18, 2004, now Pat. No. 7,093,828.

(60) Provisional application No. 60/511,660, filed on Oct. 17, 2003.

(51) **Int. Cl.**
B25B 5/16 (2006.01)
B25B 5/06 (2006.01)
B25B 27/02 (2006.01)

(52) **U.S. Cl.**
CPC **B25B 5/16** (2013.01); **B25B 5/067** (2013.01); **B25B 5/068** (2013.01); **B25B 27/02** (2013.01)

(58) **Field of Classification Search**
CPC B25B 5/16; B25B 5/067; B25B 5/068; B25B 5/101
See application file for complete search history.

(56) **References Cited**

U.S. PATENT DOCUMENTS

D162,910 S	4/1951	Wallace	D8/354
2,876,814 A	10/1955	Leister		
2,947,333 A	7/1958	Johnson		
3,096,975 A	7/1963	Irwin		
3,210,070 A	10/1965	Lagana		

(Continued)

OTHER PUBLICATIONS

Bessey KlikKlamp display and sales information, Date Aug. 5, 2004.

(Continued)

Primary Examiner — Lee D Wilson

(74) *Attorney, Agent, or Firm* — Wolff Law Offices PLLC; Kevin Alan Wolff

(57) **ABSTRACT**

The present invention is directed generally to tools that are high quality, strong, and lightweight. For example, various tools such as clamps may be made using parts containing a compound or alloy including magnesium. Magnesium may be for cast or extruded parts. In one embodiment, an “F” style clamp may be made with one or both of the two cooperating jaw members or sections being cast from a magnesium compound or alloy. In one variation, the “F” style clamp may include a shaft made from extruded magnesium. In another embodiment, a “C” style clamp may be made with the “C” shaped frame being cast from a magnesium compound or alloy. In a further embodiment, a bar clamp having trigger indexing may be made with one or both of two jaw members or sections being cast from a magnesium compound or alloy. In a variation, the bar may be an extruded magnesium.

20 Claims, 9 Drawing Sheets

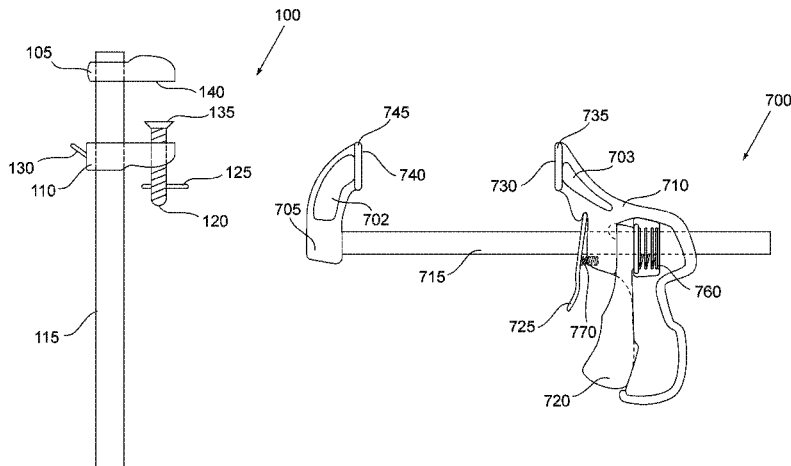

(56)

References Cited

U.S. PATENT DOCUMENTS

3,357,968 A 12/1967 Flynn 269/221
 4,081,170 A 3/1978 Doss, Jr. 251/5
 4,132,397 A 1/1979 Ward 269/252
 4,220,322 A 9/1980 Hobday 269/6
 4,488,696 A 12/1984 Sauber 248/74.1
 4,563,921 A 1/1986 Wallace 81/373
 4,786,124 A 11/1988 Stone et al. 359/15
 4,786,214 A 11/1988 Schmidt et al. 405/303
 4,834,354 A 5/1989 Yang 269/156
 4,874,155 A 10/1989 Goul 269/6
 4,893,801 A 1/1990 Flinn 269/6
 4,926,722 A 5/1990 Sorensen et al. 81/487
 5,009,134 A 4/1991 Sorensen et al. 81/487
 5,015,116 A 5/1991 Nardone et al. 403/28
 D320,919 S 10/1991 Sorensen D8/72
 5,161,787 A 11/1992 Hobday 269/6
 5,454,551 A 10/1995 Hobday 269/6
 5,826,310 A 10/1998 Hobday 24/514

6,708,966 B1 3/2004 Troutd 269/249
 6,726,193 B1 4/2004 Yates 269/184
 6,848,683 B2 2/2005 Foshag et al. 269/3
 7,093,828 B2* 8/2006 Murray B25B 5/067
 269/3
 7,896,323 B2* 3/2011 Murray B25B 5/067
 269/166
 8,641,024 B1* 2/2014 Murray B25B 5/067
 269/143
 9,427,848 B1* 8/2016 Murray B25B 5/067
 2003/0116901 A1 6/2003 Roesch 269/6
 2005/0082730 A1 4/2005 Murray et al. 269/166

OTHER PUBLICATIONS

“Superplastic Magnesium Alloys for Sporting and Leisure Equipments”, Materials and Science in Sports, Proceedings of a Symposium, Coronado, CA, US, Apr. 22-25, 2001, Tan, J.C.; Tan, M.J. (pp. 43 and 44 of STIC Search Report).

* cited by examiner

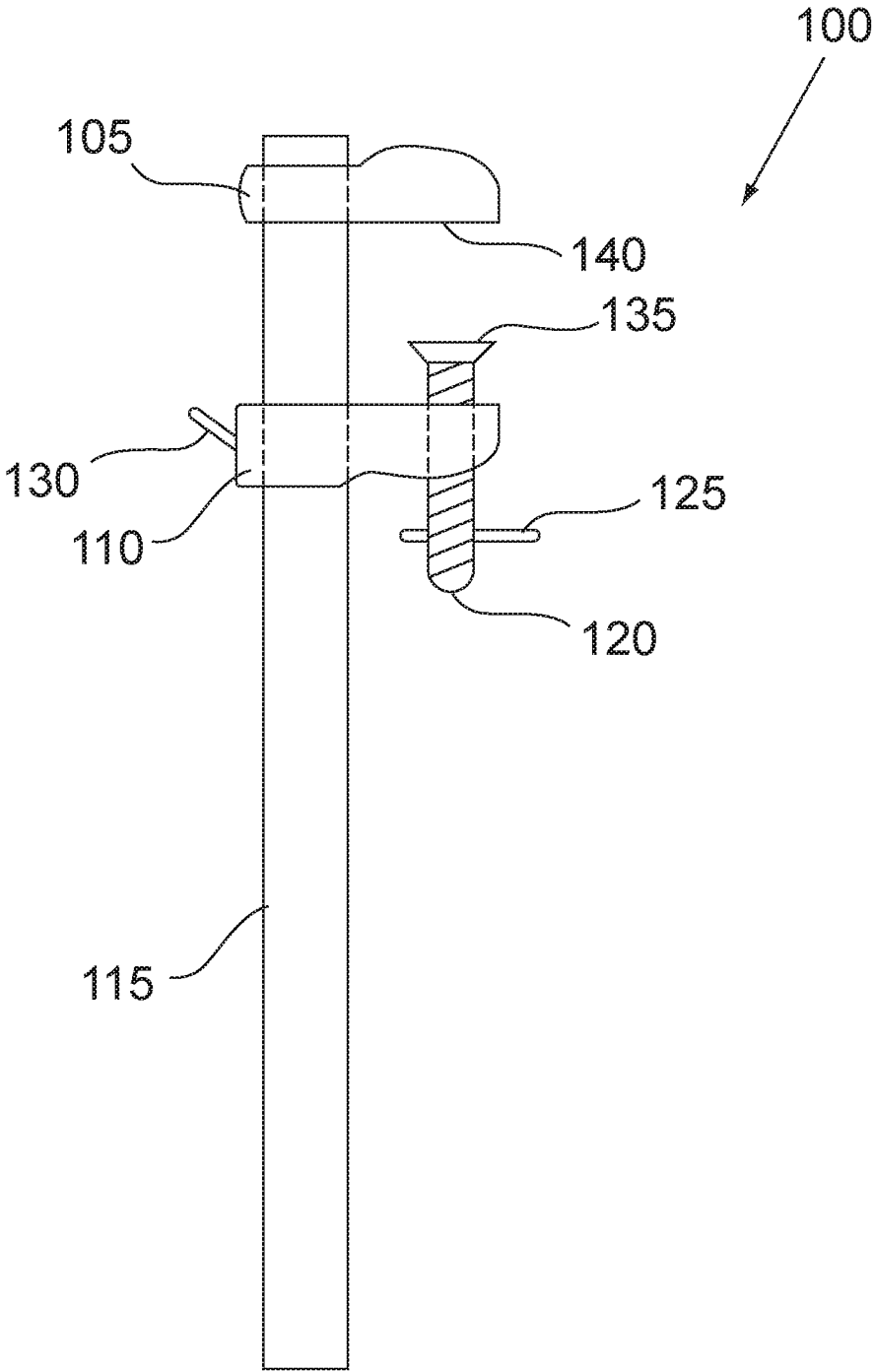

Figure 1

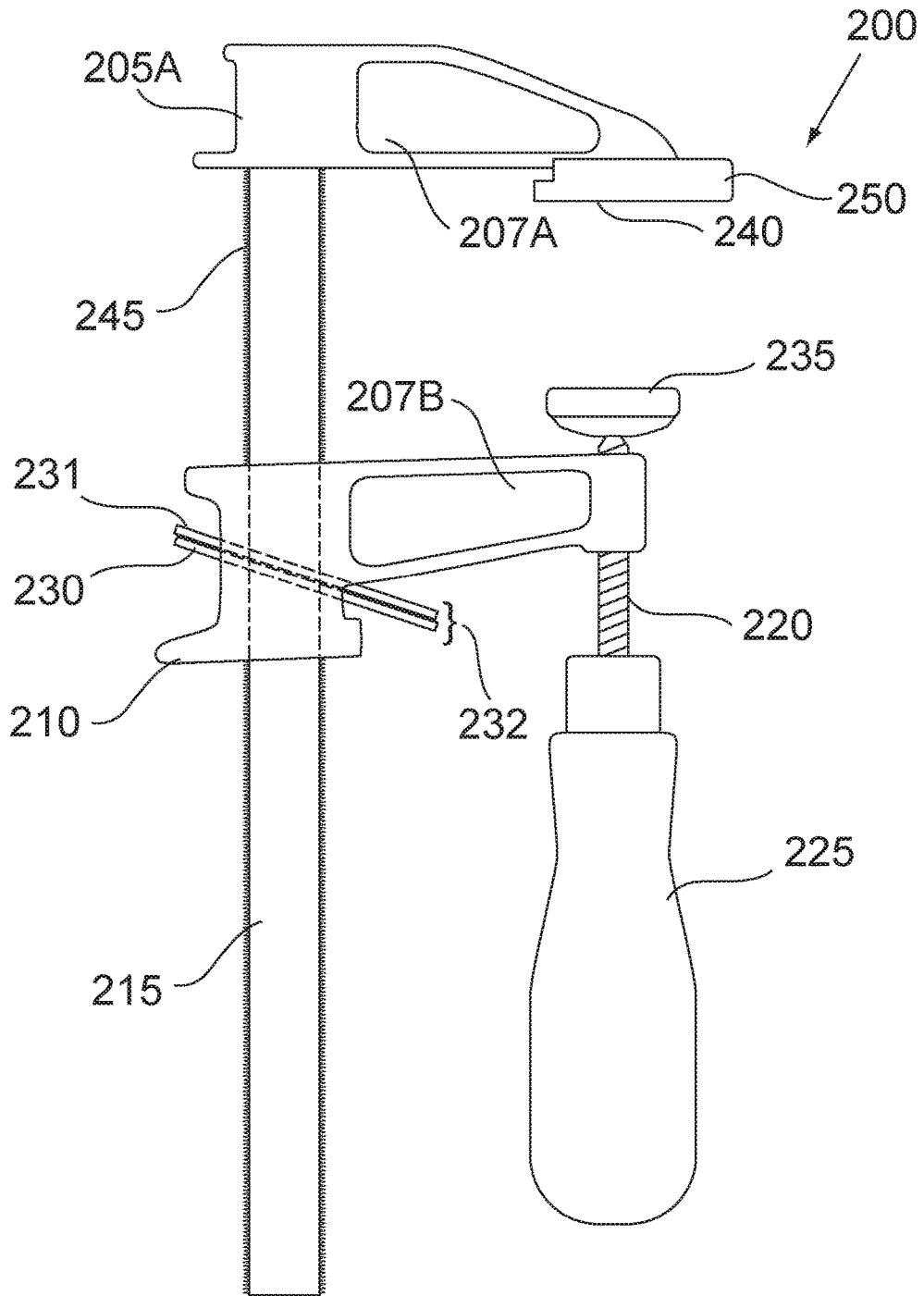

Figure 2A

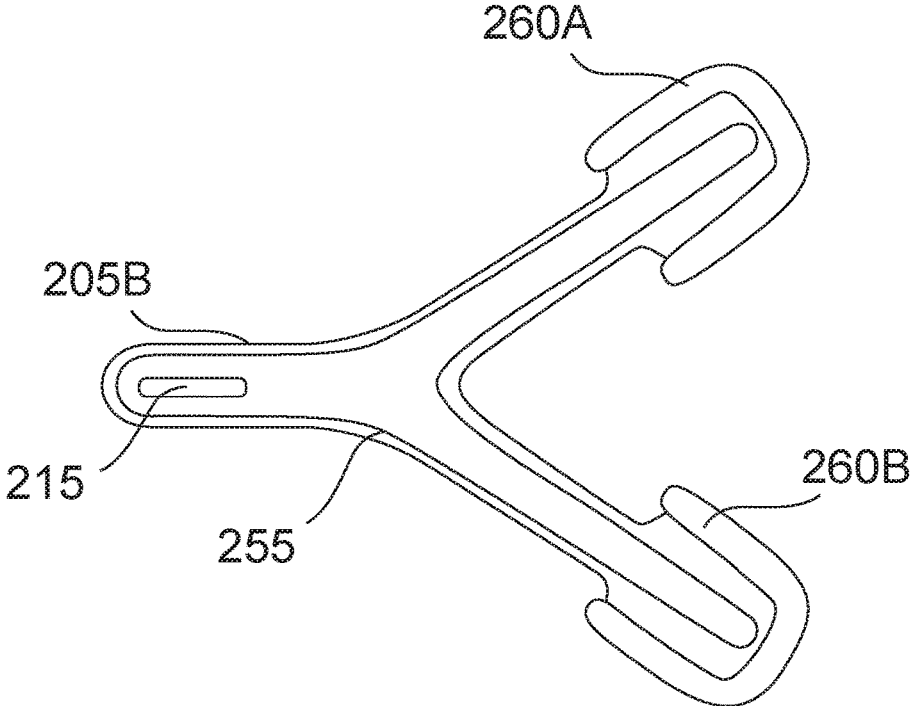

Figure 2B

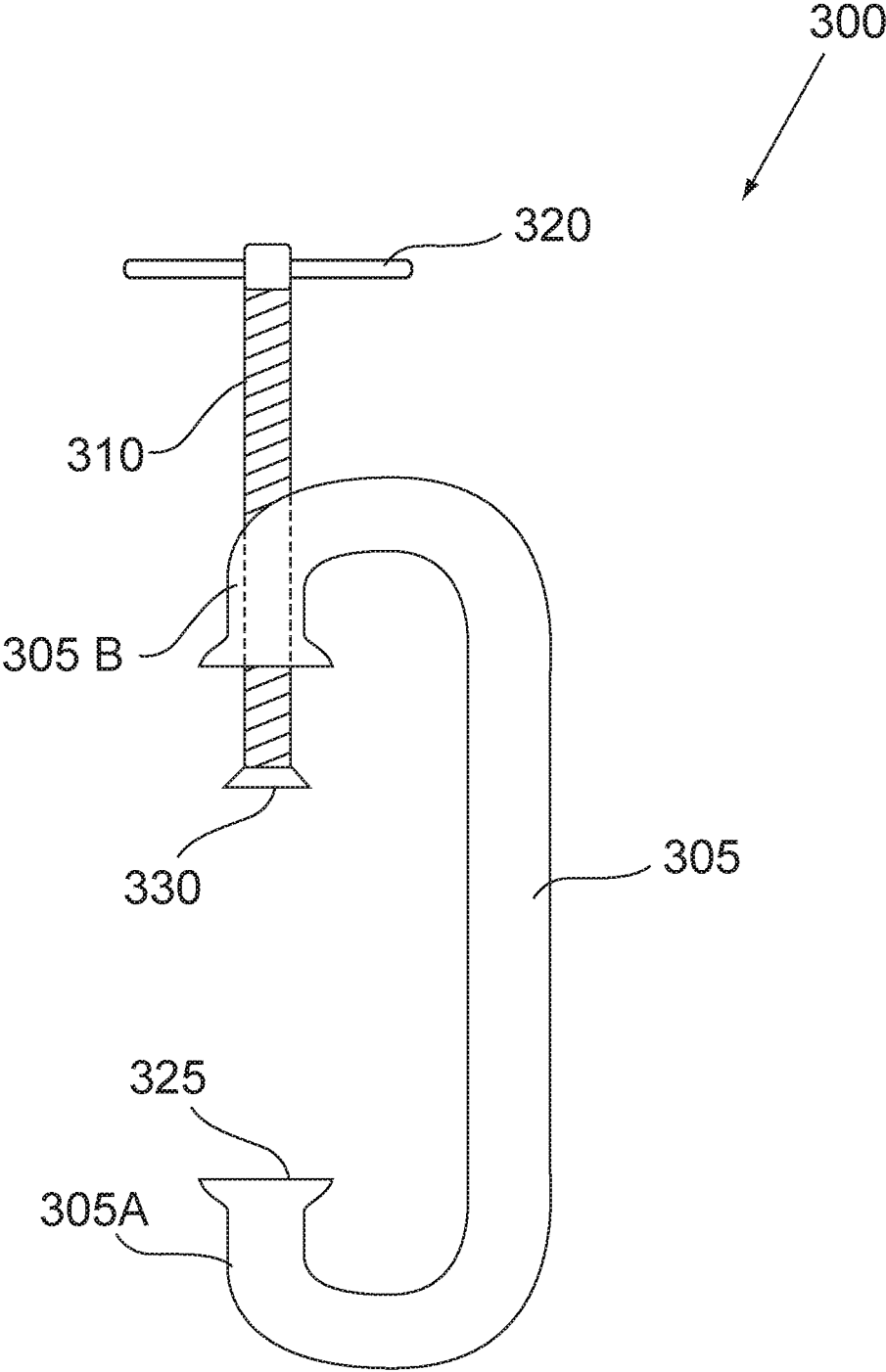

Figure 3

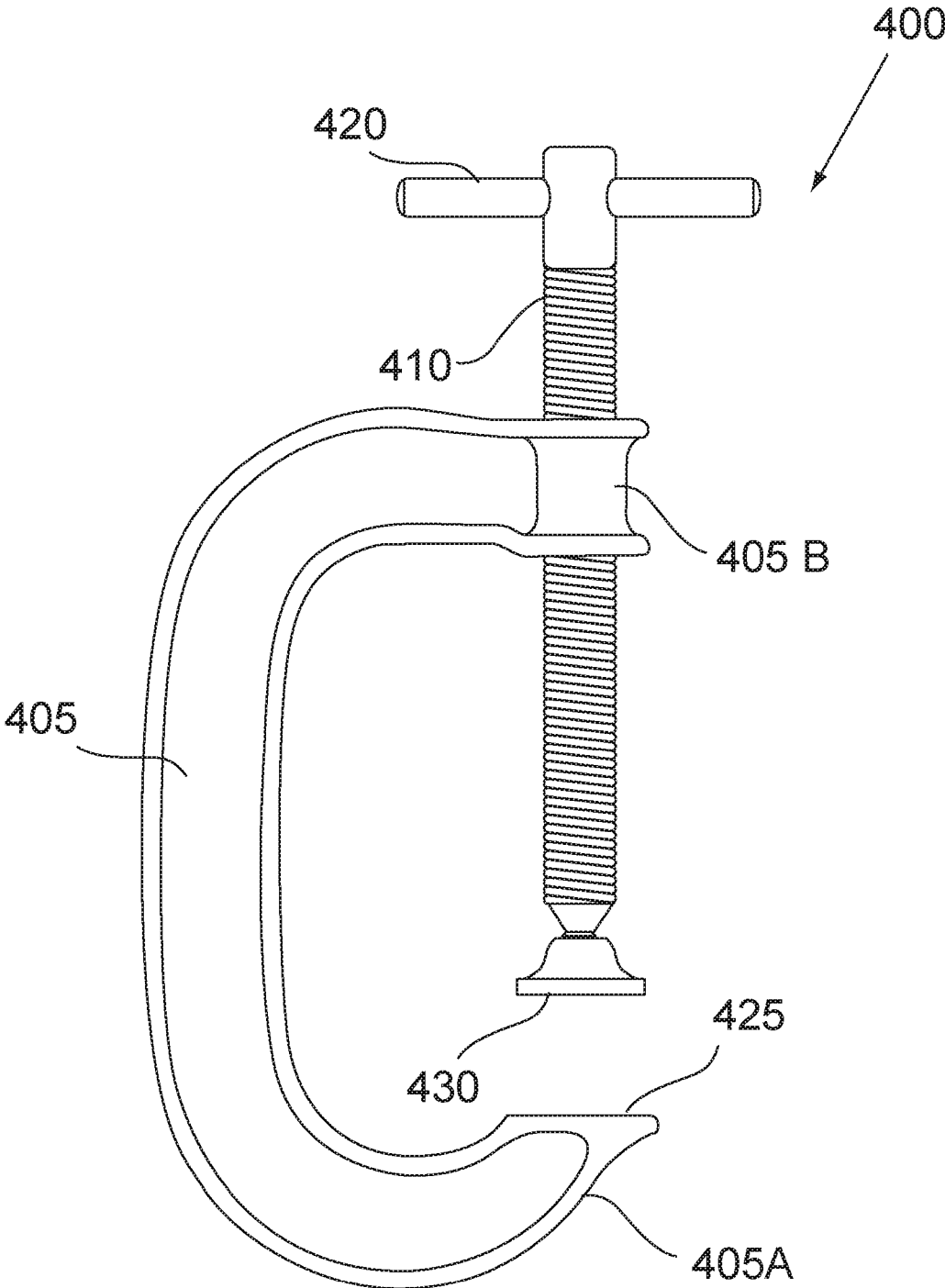

Figure 4

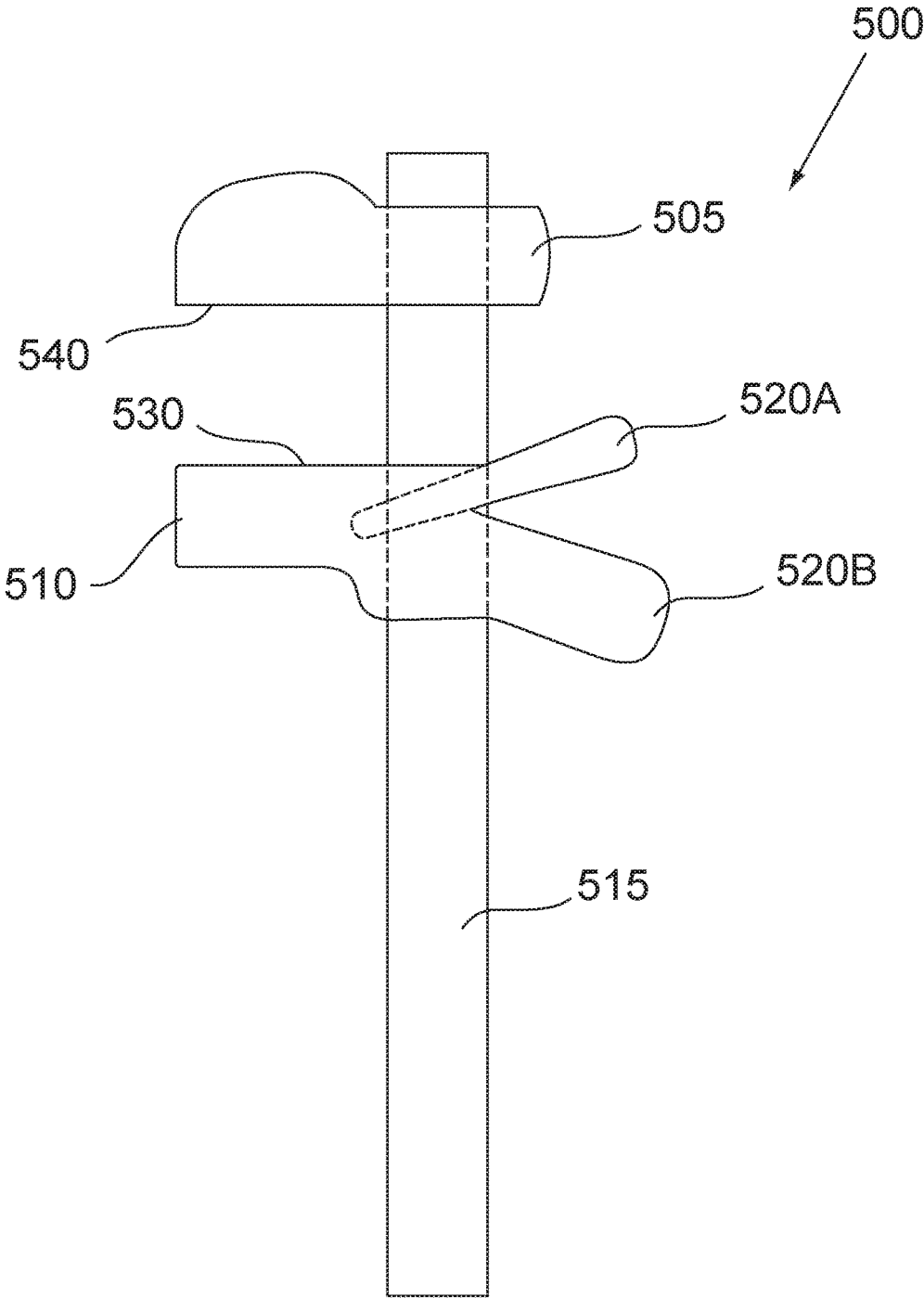

Figure 5

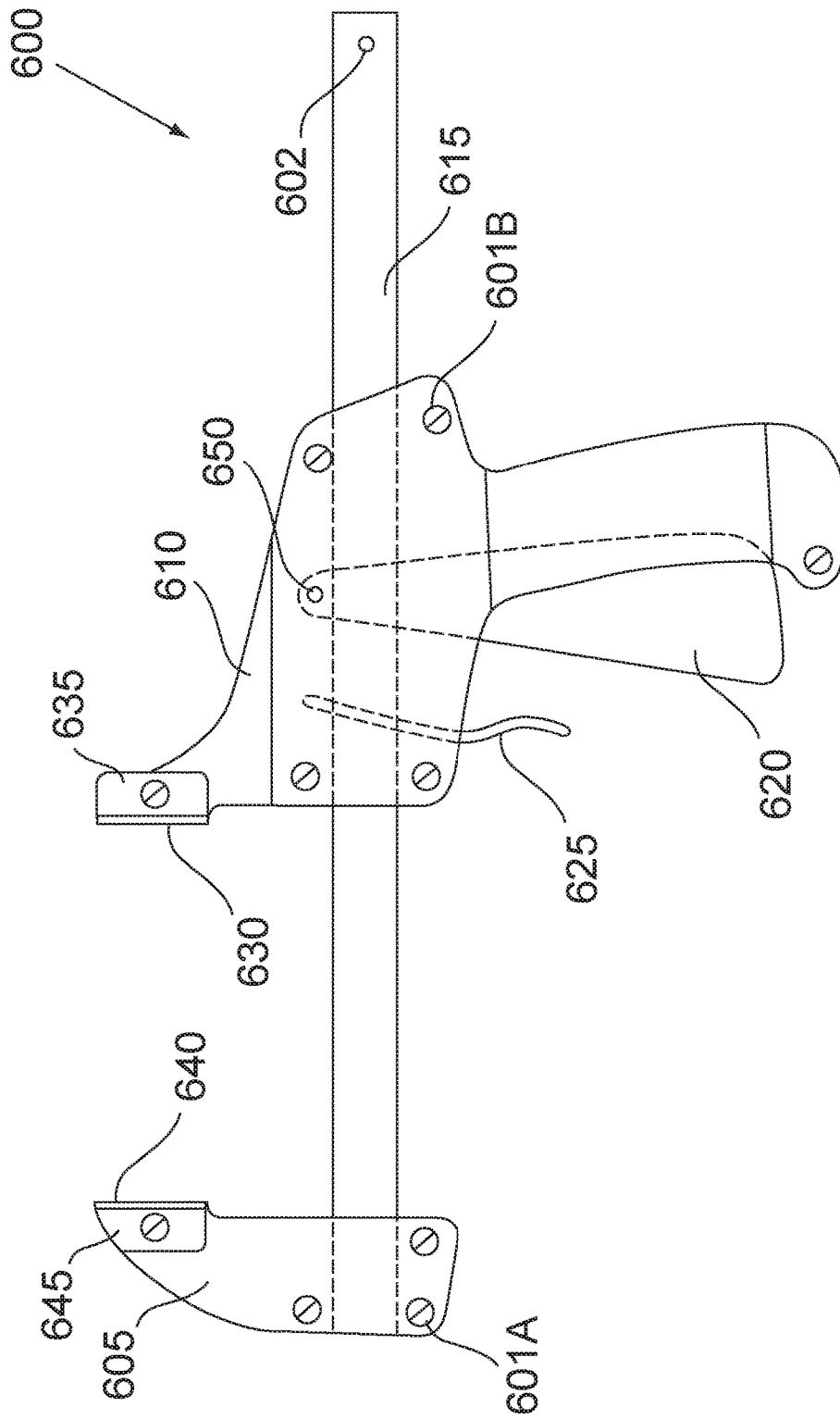

Figure 6

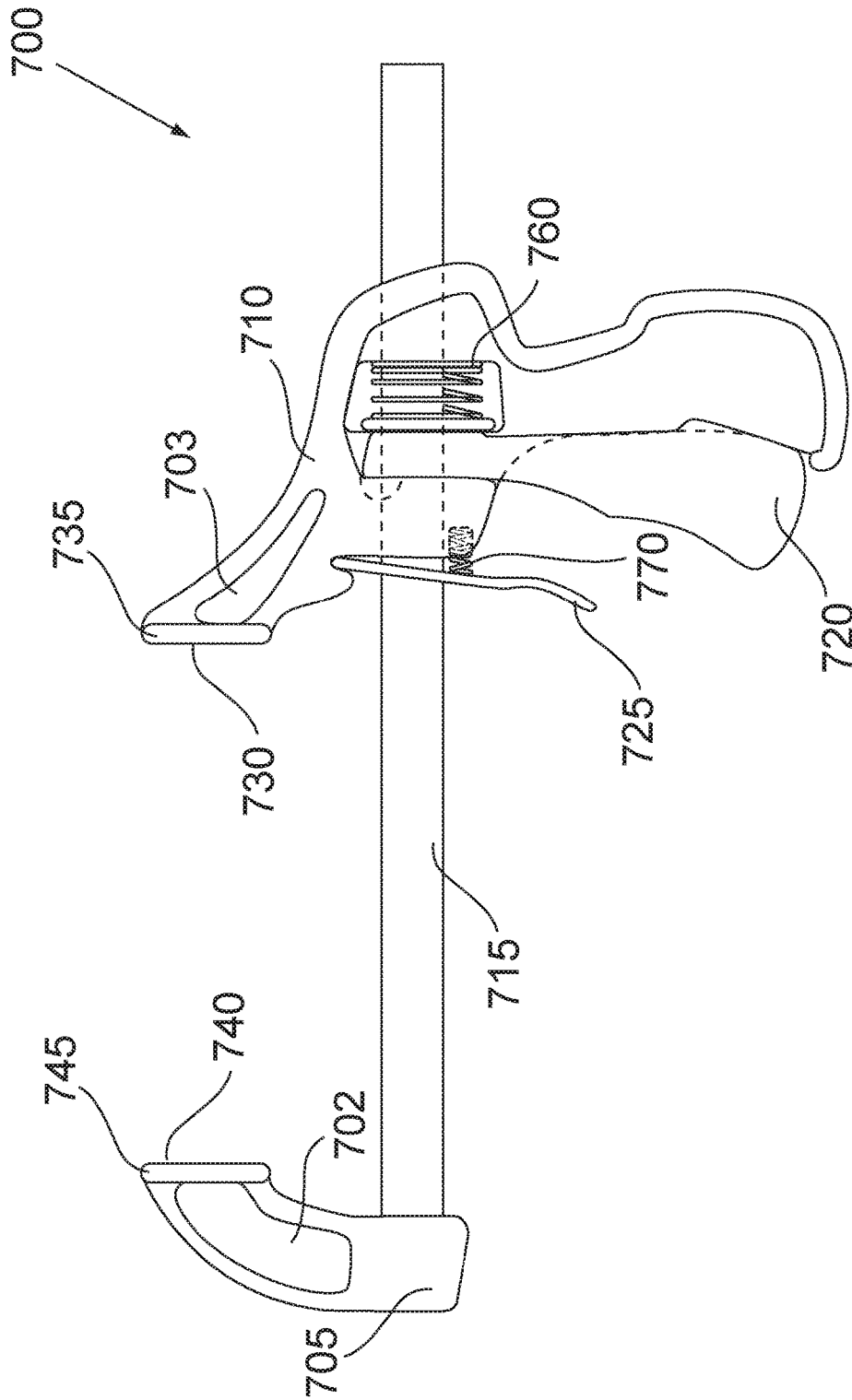

Figure 7

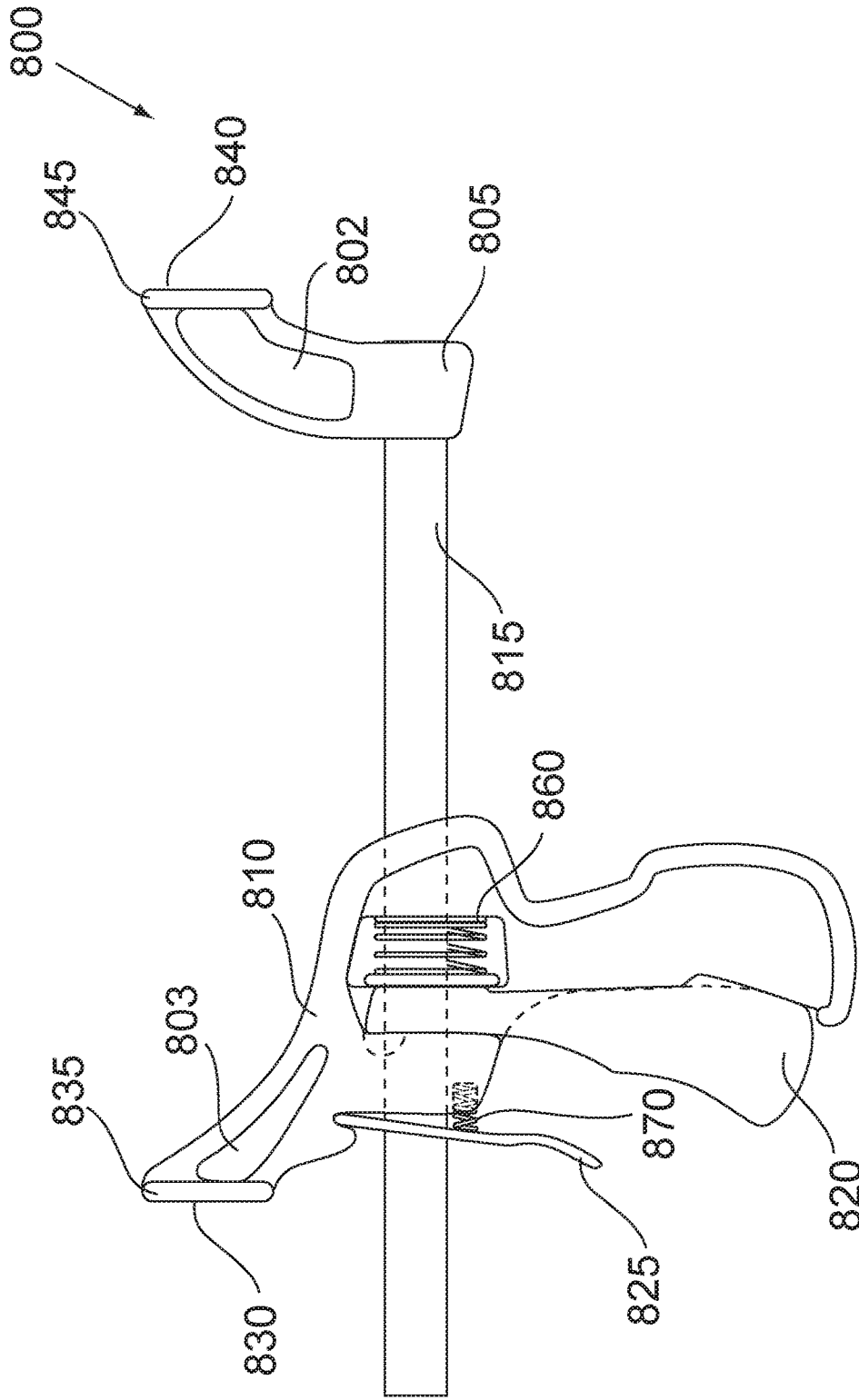

Figure 8

METHODS AND APPARATUS FOR CLAMPING TOOLS

This patent application is a continuation application of U.S. patent application Ser. No. 14/171,731 filed Feb. 3, 2014, now to issue shortly as U.S. Pat. No. 9,427,848, which is a continuation application of U.S. patent application Ser. No. 13/037,204 filed Feb. 28, 2011, now U.S. Pat. No. 8,641,024, which is a continuation application of U.S. patent application Ser. No. 11/383,201 filed May 13, 2006, now U.S. Pat. No. 7,896,323, which is a continuation application of U.S. patent application Ser. No. 10/965,958 filed Oct. 18, 2004, now U.S. Pat. No. 7,093,828, which relates to U.S. Provisional Patent Application No. 60/511,660 filed on Oct. 17, 2003, which are all incorporated herein in their entirety for all purposes.

FIELD OF THE INVENTION

The present invention pertains to methods and various apparatus for building tools. For example, the invention involves methods and various apparatus for high quality, durable and in some case lightweight building tools.

BACKGROUND

Various work piece clamping or spreading tools have been known in the past for working with, spreading, holding and/or clamping together various work pieces or items being worked on. How to make and use such tools is generally known in the art as shown by, for example, various designs disclosed in U.S. Pat Nos. 2,876,814; 2,947,333; 3,096,975; 3,210,070; 3,357,698; 4,132,397; 4,220,322; 4,874,155; 4,893,801; 4,926,722; 5,161,787; and 6,708,966, which are incorporated herein by reference. Some examples of typical types of clamps include the "F" style bar clamp having screw and indexing adjustments, "C" style clamps having screw adjustment, and bar clamps having trigger indexing adjustment. Traditionally the "F" style bar clamp has been made of cast iron or steel jaw parts placed along or over a steel shaft. Traditionally the "C" style clamp has been made of cast iron or steel. Traditionally the bar clamp having trigger indexing adjustment have been made of plastic or glass-filled nylon jaw parts and trigger along or over a steel bar. Work piece spreaders may be constructed of similar components and materials, but exert force pushing apart or away from one another so as to spread apart a work piece or portions thereof. Regardless, the traditional materials often make the clamps somewhat heavy in weight due to the use of steel and/or iron for strength to meet the stress and forces that the clamps and/or spreaders experience when used to hold a work item. Therefore, it is advantageous to build such clamps to be light in weight yet strong enough to withstand the stress and forces that the clamps experience when closed to hold a work item.

SUMMARY

The present invention is directed generally to tools that are high quality, strong, and lightweight. For example, various tools such as clamps and/or spreaders may be made using parts containing a compound or alloy including magnesium. Magnesium may be used to reduce the weight of the cast or extruded parts of the clamps and/or spreaders. In one embodiment, an "F" style clamp may be made with one or both of the two cooperating jaw members or sections being cast from a magnesium compound or alloy. In one variation,

the "F" style clamp may include a shaft made from extruded magnesium. In another embodiment, a "C" style clamp may be made with the "C" shaped frame being cast from a magnesium compound or alloy. In a further embodiment, a bar clamp having trigger indexing may be made with all or a portion of one or both of two jaw members or sections being cast from a magnesium compound or alloy. In a variation, the bar may be made of extruded magnesium. In another embodiment, a work piece spreader may include one or more parts made from a material including magnesium.

BRIEF DESCRIPTION OF THE DRAWINGS

The objects, features and advantages of the present invention will become more readily apparent to those skilled in the art upon reading the following detailed description, in conjunction with the appended drawings, in which:

FIG. 1 illustrates an "F" style clamp, according to one embodiment of the invention; FIG. 2A illustrates an "F" style clamp, according to another embodiment of the invention;

FIG. 2B illustrates a portion of an "F" style clamp, according to a still further embodiment of the invention;

FIG. 3 illustrates a "C" style clamp, according to one embodiment of the invention;

FIG. 4 illustrates a "C" style clamp, according to another embodiment of the invention;

FIG. 5 illustrates a bar style clamp with trigger indexing, according to one embodiment of the invention;

FIG. 6 illustrates a bar style clamp with trigger indexing, according to another embodiment of the invention;

FIG. 7 illustrates a bar style clamp with trigger indexing, according to another embodiment of the invention; and

FIG. 8 illustrates a bar style work piece spreader with trigger indexing, according to one embodiment of the invention.

DETAILED DESCRIPTION

The present invention is directed generally to tools that are high quality, strong, durable, and lightweight. As such, the present invention includes various embodiments showing methods and various apparatus for clamps and/or work piece spreaders that may be, at least in part, made of a magnesium compound or alloy.

Referring to FIG. 1, an "F" style clamp **100** is illustrated. In this embodiment, the "F" style clamp may include a first jaw member **105** and a second jaw member **110** that may be coupled to a shaft or bar **115**. The shaft may be, for example, a pipe or a straight bar rectangular in shape. Further, the first jaw member **105** may be set to a fixed position on the shaft or bar **115** by, for example, being securely attached to the shaft **115** using friction, welding, screws, bolts and nuts, rivets threads, etc., so that it does not move when a work item is squeezed in the clamp. Further, the second jaw member **110** may be movable along the shaft **115** and may have a moveable indexing mechanism **130** for holding or releasing the second jaw member **110** in a particular position along the shaft **115** so as to provide the "F" style clamp with course length or distance adjustment between the first jaw member **105** and the second jaw member **110**. The indexing mechanism **130** may ride against the shaft **115** with the assistance of a spring or tension member (not shown). The shaft **115** may movably fit through a hole in the second jaw member **110** and the movable indexing mechanism **130**. There may also be fine adjustment for the clamp by including a threaded member **120** (like a screw or bolt) that may

be turned using handle **125** that is inserted into a hole in the threaded member **120**. The threaded member **120** may have a head **135** that may interface with a work item to be held in the clamp **100**. The interface head **135** may be coupled to the threaded member **120** and operate in conjunction with the opposing flat surface **140** of the first jaw member **105**, between which a work piece may be held or clamped. In one variation, the second jaw member **110** may be stationary on the shaft or bar **115** and the first jaw member **105** may move. In another variation, both the first jaw member **105** and the second jaw member **110** may be adjustable and be movable along the shaft or bar **115**.

In one embodiment, the “F” style clamp **100** may be made with the first jaw member **105** and/or the second jaw member **110** including magnesium material. The magnesium material may be a compound or alloy and may be, for example, a cast magnesium compound piece. The magnesium compound or alloy may be made partially or primarily of magnesium (Mg) to provide light weight and have various other materials or elements so as to increase its strength and durability. In the past, it was believed that a magnesium compound or alloy was not of sufficient strength to be used in clamping or spreading devices. However, the present inventors have found that magnesium compound or alloy may be formulated to have sufficient strength for use in various clamping or spreading devices and provide lighter weight tools. For example, one magnesium compound or alloy, may include the following substances in the following amounts: Aluminum (Al) at 8.5% to 9.5%; Copper (Cu) at 0.25% maximum; Manganese (Mn) at 0.15% minimum; Nickel (Ni) at 0.01% maximum; Silicon (Si) at 0.20% maximum; Zinc (Zn) at 0.45% to 0.9%; other materials (OT) at 0.30% maximum; and Magnesium (Mg) is the % remainder. This composition of Magnesium is particular good for forming parts by casting. However, other formulations are possible, such as the formulation of the magnesium alloy may vary within the above by +/-5% for Al and Mg, and +5% for Mn.

Using the aforementioned formulation, it has been found that, for example, an “F” style clamp with one or more jaws made of magnesium may have a strength sufficient to withstand a clamping or spreading force of, for example, approximately 3 kN (kilo-Newtons) or greater without breaking or fracturing under the force of the clamp, using a US type of test setup. In this type of testing, it has been shown that a clamp having two jaws made of the aforementioned magnesium compound can withstand approximately 3.3 kN of clamping force for up to four hours without breaking, fracture or signs of fatigue. The “F” clamp according to the invention using this test setup has been shown to achieve a maximum force capability of approximately 4 kN before experiencing degradation. Further, the clamp or spreader when using a European type test setup may withstand approximately 5 kN of clamping or spreading force without breaking or fracturing. In this type of testing, it has been shown that a clamp having two jaws made of the aforementioned magnesium compound can withstand approximately 5.3 kN of clamping force for up to six hours without breaking, fracture or signs of fatigue. The “F” clamp according to the invention using this test setup has been shown to achieve a maximum force capability of approximately 6 kN before experiencing degradation. Similar type of strength performance may be shown for other types of clamps and spreaders using the aforementioned magnesium compound or similar magnesium compounds.

In one variation, the “F” style clamp **100** may have a shaft, pipe or bar **115** that includes Magnesium. The shaft or

bar **115** may include a compound or alloy of magnesium material and may be, for example, an extruded magnesium compound piece. The magnesium compound or alloy may be made partially or primarily of magnesium (Mg) to provide light weight and have various other materials or elements so as to increase its strength and durability. For example, one magnesium compound or alloy particularly well suited to extrusion may include the following substances in the following amounts: Aluminum (Al) at 2.5% to 3.5%; Copper (Cu) at 0.05% maximum; Iron (Fe) at 0.005% maximum; Manganese (Mn) at 0.20% minimum; Nickel (Ni) at 0.005% maximum; Silicon (Si) at 0.30% maximum; Zinc (Zn) at 0.60% to 1.4%; Calcium at 0.3% maximum; other materials (OT) at 0.30% maximum; and Magnesium (Mg) is the % remainder. This composition of Magnesium is particular good for forming parts by extrusion. The formulation may have variations from those above, for example, the composition of magnesium may vary within the above by -2.5% to 5% for Al and Mg, and +5% for Mn. In another variation, the shaft or bar **115** may be formed from casting rather than extrusion. Although, the shaft or bar **115** may be made of, for example, aluminum, iron, steel, etc., along with other straight parts.

It is understood that the “F” style clamp may have various different shaped jaws or shafts and still utilize the unique properties of the present invention. For example, another embodiment of an “F” clamp design is show in FIG. 2A. In this embodiment, the “F” style clamp is similar to the “F” style clamp shown in FIG. 1 with a number of differences. For example, a first jaw **205** may be constructed differently to have a void area **207A** and a second jaw **210** may be construed having a void area **207B** to further reduce the weight of the jaws when used with a magnesium compound or alloy. In this case, the first jaw **205A** may have a single work piece interface surface **240**. Further, the first jaw **205** may have a pad **250** made of a resilient material, for example a plastic or rubber material, to interface with a surface of a work piece that is held between the jaws of the clamp. Similarly, the head **235** may also include a flexible resilient material that contacts a surface of a work piece. A handle **225** may also be attached to a threaded member **220**, for making fine adjustment to the pressure applied to a work piece. The shaft, pipe or bar **215** may also include a roughened surface **245** to improve the holding strength between the jaw **210** and the shaft **215**, that may be made of a magnesium compound or alloy. In addition the moveable indexing mechanism **232** may include two plates or sections **230** and **231** for holding or releasing the second jaw member **210** and extend through a through hole in the second jaw member **210** so as to extend on both sides. In this case, the movable indexing mechanism **232** may be activated from two sides of the second jaw member **210**. The indexing mechanism **232** may ride against the shaft **215** with the assistance of a spring or tension member (not shown).

Referring to FIG. 2B, a top view of a different type of jaw useful for clamps and/or spreaders is shown. In this case there are two separate arms to the jaw **205B** having work piece interface pads **260A** and **260B**. The jaw **255** may also have an angle iron type shape having material with an L shape to improve strength of the two arm jaw **205B**. The pads **260A** and **260B** may include a resilient and/or flexible material such as rubber or plastic. The jaw **255** may be attached then to the shaft **215**.

Referring now to FIG. 3, one embodiment of a “C” style clamp is illustrated. The “C” clamp may include jaws **305** having a first jaw member **305A** and a second jaw member **305B** integrally formed with an elongated shafts section to

5

form the shape of a "C." The integral jaws **305** (including **305A** and **305B**) may be formed of a Magnesium compound similar to the Magnesium compound used for making the "F" style clamp of FIG. 1. In one variation, one or more sections of the jaws **305** may be formed of a Magnesium compound or alloy using, for example, a casting process. Further, the "C" style clamp includes a threaded member **310** that may be threaded through a threaded hole in second jaw member **305B**. A handle member **320** may be coupled to the threaded member **310** through a hole in one end of the threaded member **310**. An interface head may be coupled to the opposite end of the threaded member **310**. The "C" style clamp may have only one means of adjustment; by turning the handle member **320** and thereby the threaded member **310** the interface head may apply pressure to a work piece situated between first jaw member **305A** and the threaded member **310** with interface head. The various portions of the "C" clamp **300** may be made of a magnesium compound or alloy such as those described above for the "F" clamps or similar compounds, to reduce the weight of the clamp and may be capable of supporting a clamping force of approximately 3 kN or greater, or approximately 5 kN or greater, without breaking or fracturing.

Referring now to FIG. 4, another embodiment for a "C" clamp is shown. This "C" clamp is similar to the earlier described "C" clamp in most respects, however, the design is different in a number of ways. For example, the C shaped frame **405** has only one end shaped in a curve that looks like a C, end **405A**, while the other end **405B** is not curved much. As a result, the C shape of the clamp **400** is complete by a portion of the threaded member **410**. Further, in this embodiment, the strength of the light weight magnesium frame can be increased by including an angle iron ribs around the perimeter of the clamp frame **405**. Again, a work piece may be coupled between surface **425** and **430** by turning the threaded member **410** using the handle member **420**. Further, the various portions of the "C" clamp **400** may be made of a magnesium compound or alloy such as those described above for the "F" clamps (or similar magnesium compounds), to reduce the weight of the clamp, and may be able to withstand a clamping force of approximately 3 kN or greater, or approximately 5 kN or greater, without breaking or fracturing.

Referring now to FIG. 5, a trigger indexing bar clamp **500** is illustrated. In this embodiment, the trigger indexing bar clamp may include a first jaw member **505** and a second jaw member **510** that may be coupled to a shaft or bar **515** by, for example, a hole in the jaw members. The shaft **515** is preferably a bar but may be, for example, a pipe or other rigid elongated shape. Further, the first jaw member **505** may be set to a fixed position on the shaft or bar **515** by, for example, being securely attached to the shaft **515** using friction, welding, screws, bolts and nuts, rivets threads, etc., so that it does not move when a work piece or item is squeezed in the clamp. In one variation, the first jaw member may be movable and adjustable along the shaft **515**. Further, the second jaw member **510** may be movable along the shaft **515** by the assistance of an indexing mechanism **520** including, for example, a pumping trigger **520B** for moving second jaw member **510** towards first jaw member **505** to hold a work piece and a hold and release trigger **520A** for holding the second jaw member **510** in a particular position along the shaft **515** and releasing the second jaw member when wishing to release a work piece. In the trigger indexing bar clamp **500** the pumping trigger **520B** and hold and release trigger **520A** provide the only mechanism for moving the second jaw member **510**.

6

Various portions of the trigger indexing bar clamp **500** may be made of material including magnesium so that it reduces the weight of the clamp yet still has the strength necessary to be used in various applications as a clamp without fracturing, fatiguing, or breaking. In one variation the material make up of at least some of the parts are a compound or alloy including magnesium, such as the magnesium compounds or alloys described above with reference to the "F" style clamp, and similar compounds or alloys. The magnesium may be used for cast or extruded parts. In one variation, the first jaw member **505** may be made of cast magnesium compound or alloy and one or more of the second jaw member **510**, pumping trigger **520B** and hold and release trigger **520A** may be made of cast magnesium compound or alloy. In one variation, the trigger indexing bar clamp may include a shaft or bar **515** made from extruded magnesium. Although, the shaft or bar **515** may be made of, for example, aluminum, iron, steel, etc., along with various other parts.

Referring to FIG. 6, another type of trigger indexing clamp is shown. Trigger indexing clamp **600** is similar to the trigger clamp **500** and may include a first jaw member **605**, but it may be made in two sections (one side shown) that are held together by bolts or screws **601A**. In this manner, the first jaw may be moved along the shaft **615** by loosening the bolts or screws **601A**, relocating the first jaw at another location on the shaft **615**, and then tightening the bolts or screws. The first jaw member **605** may also have a separate piece **645** couple to it so as to provide the contact surface **640**. The second jaw member **610** may also be made of two parts (one shown) held together with bolts or screws **601B** and may include a pumping or stepping trigger **620** that inserts into a handle portion of the second jaw member **610** and pivots on a pin **650**. The trigger **620** may be forced into a resting position via a spring mechanism (not shown). When the trigger **620** is moved toward the handle of the second jaw member **610**, the second jaw member **610** will move along the shaft **615** toward the first jaw member **605**. The second jaw member **610** may also include a release trigger **625** that may be pressed to release the second jaw member **610** so that it may be moved along the shaft **615** freely in either direction, toward or away from the first jaw member **605**. The second jaw member **610** may also have a separate piece **635** couple to it so as to provide the contact surface **630**. A stop pin **602** may also be place on one end of the shaft **615**.

Various portions of the trigger indexing bar clamp **600** may be made of material including magnesium so that it reduces the weight of the clamp yet still has the strength necessary to be used in various applications as a clamp without fracturing, fatiguing, or breaking. In one variation the material make up of at least some of the parts are a compound or alloy including magnesium, such as the magnesium compounds or alloys described above with reference to the "F" style clamp, and similar compounds or alloys. The magnesium may be used for cast or extruded parts. In various variations, the first jaw member **605** may be made of cast magnesium compound or alloy and one or more of the second jaw member **610** with handle, pumping trigger **620** and/or hold and release trigger **625** may be made of cast magnesium compound or alloy. In one particular variation, the first jaw **605** and second jaw **610** may be made of a cast magnesium compound while the trigger **620** may be made of a hard plastic. In one variation, the trigger indexing bar clamp **600** may include a shaft or bar **615** made from

extruded magnesium. Although, the shaft or bar **615** may be made of, for example, aluminum, iron, steel, etc., along with various other parts.

Referring now to FIG. 7, another version of a trigger indexing bar clamp **700** is shown. This trigger indexing bar clamp **700** is similar to the trigger indexing bar clamp **600**, but may have a solid piece for the first jaw member **705** with a sunken hallowed out area **702** surrounded by ribs and a solid piece for the second jaw member **710** with a sunken hallowed out area **703** surrounded by ribs. The hallowed out areas **702** and **703** may help to reduce weight of the clamp and the ribs may help improve the strength of the clamp. Pad **745** and/or work piece contact surface **740** and pad **735** and/or work piece contact surface **730** may be of a flexible resilient material, such as rubber. The pumping or stepping trigger **720** may be formed to go around the sides of the second jaw member **710** handle portion (i.e., the trigger **720** is wider than the handle portion). In this embodiment, the spring member **760** is shown to apply pressure to the back of the trigger **720** so that it returns to its normal position after being pressed and released. The release trigger **725** in this embodiment is almost entirely external to the second jaw member **710**, except for a portion of its tension spring member. Of course, various parts of this clamp may be made of a magnesium compound or alloy to reduce weight of the clamp while achieving a strength sufficient to withhold a clamping force of approximately 3 kN or greater, or approximately 5 kN or greater, without breaking or fracturing. In one particular variation, the first jaw **705** and second jaw **710** may be made of a cast magnesium compound while the trigger **720** may be made of a hard plastic.

Most of the aforementioned "F" style clamps and trigger indexing bar clamps may be configured to be operated as a work piece spreader by turning the jaw and the work piece contact surfaces in opposite directions so that a force can be applied in away from one another rather than toward one another. Referring to FIG. 8, a modified clamp similar to clamp **700** shown in FIG. 7 is used to illustrate on version of a work piece spreader **800**. In this case, a first jaw member is facing outward from the shaft **815** and second jaw member **810**. As shown, in this embodiment the work piece contact surfaces **830** and **840** are facing in opposite directions so that they may be used to spread a work piece. As with the aforementioned clamps, the spreader **800** may have various parts made of a magnesium compound or alloy to reduce weight of the clamp while achieving a strength sufficient to withhold a spreading force of approximately 3 kN or greater, or approximately 5 kN or greater, without breaking or fracturing. In one particular variation, the first jaw **805** and second jaw **810** may be made of a cast magnesium compound while the trigger **820** may be made of a hard plastic.

Although a particular embodiment(s) of the present invention has been shown and described, it will be understood that it is not intended to limit the invention to the preferred embodiment(s) and it will be obvious to those skilled in the art that various changes and modifications may be made without departing from the spirit and scope of the present invention. Thus, the invention is intended to cover alternatives, modifications, and equivalents, which may be included within the spirit and scope of the invention as defined by the claims. For example, forming various parts of other clamp or spreader designs or styles using a magnesium compound or alloy may be alternative embodiments of the present invention. For example, the lever clamp design disclosed in U.S. Patent Application Publication No. 2003/0116901 may be modified to include portions made of a magnesium compound or alloy as described herein.

Of course, the present invention may also prove to be useful with other tools that would benefit from being light in weight yet strong when forces are exerted on them. Some of the other applications for light weight yet strong might include other hand tools such as pliers, channel locks, vise grips, wrenches, etc. Other tools might include a vise, press, cutting shears, etc.

All publications, patents, and patent applications cited herein are hereby incorporated by reference in their entirety for all purposes.

What is claimed is:

1. A clamping or spreading tool, comprising:
 - an elongate shaft;
 - a first jaw member securely mounted to the elongate shaft;
 - a second jaw member movably mounted to the elongate shaft; and
 - an adjustable member mounted to the second jaw member and having an interface head for along with a portion of the first jaw member may hold or clamp a work piece, wherein at least one piece of the clamping or spreading tool is made of, at least in part, magnesium.
2. The clamping or spreading tool of claim 1, wherein the first jaw member is made of, at least in part, magnesium.
3. The apparatus of claim 1, wherein the second jaw member is made of, at least in part, magnesium.
4. The apparatus of claim 1, wherein the elongated shaft is made of, at least in part, magnesium.
5. The apparatus of claim 1, wherein the adjustable member is made, at least in part, magnesium.
6. The apparatus of claim 1, wherein the interface head is made of, at least in part, magnesium.
7. The apparatus of claim 1, wherein the second jaw member and the adjustable member are both made of, at least in part, magnesium.
8. The apparatus of claim 5, wherein the adjustable member includes a lever element that facilitates moving the interface head or pressure plate toward and away from the work piece by moving the lever.
9. The apparatus of claim 1, wherein the clamping or spreading tool is an "F" style clamp or a bar clamp and the elongated shaft is a slide rail on which the first jaw member is a fixed arm and the second jaw member is a slide arm.
10. The apparatus of claim 1, wherein the clamping or spreading tool is a lever clamp.
11. A clamping or spreading tool, comprising:
 - a first jaw member that is configured as a fixed arm;
 - a second jaw member that is configured as a slide arm;
 - an interconnecting member that couples the first jaw member and the second jaw member together and is configured as a slide rail;
 - a fine adjustment member or lever element connected to the second jaw member and having an interface head or pressure plate mounted to it; wherein at least one of the first jaw member, second jaw member, interconnecting member, fine adjustment member and/or the interface head are made of a material including, at least in part, magnesium.
12. The clamping or spreading tool of claim 11, wherein the clamping or spreading tool is a lever clamp.
13. The clamping or spreading tool of claim 11, wherein the first jaw member is made of a compound including, at least in part, magnesium.
14. The apparatus of claim 11, wherein the second jaw member is made of a compound including, at least in part, magnesium.

15. The apparatus of claim **11**, wherein the fine adjustment member or lever element is made of a compound including, at least in part, magnesium.

16. An apparatus, comprising:

a first jaw member or slide arm made of a material including magnesium; 5

a second jaw member or fixed arm made of a material including magnesium; and

an interconnecting member or slide rail that couples the first jaw member and the second jaw member together; 10
and

a fine adjustment member or lever element connected to the second jaw member and made of a material including magnesium, having an interface head or pressure plate mounted to it, wherein the clamping or spreading tool including magnesium is constructed such that 15
when applying a predetermined maximum clamping or spreading force the apparatus does not break or fracture.

17. The apparatus of claim **16**, wherein the first jaw member and second jaw member are made of a cast magnesium metal. 20

18. The apparatus of claim **16**, wherein the fine adjustment member or lever element is made of a cast magnesium metal. 25

19. The apparatus of claim **16**, wherein the apparatus is a lever clamp having one or more parts that are made to include magnesium.

20. The apparatus of claim **16**, wherein the interconnecting member is made of a metal that is not magnesium. 30

* * * * *