



US010333249B1

(12) **United States Patent**  
**Wang**

(10) **Patent No.:** **US 10,333,249 B1**  
(45) **Date of Patent:** **Jun. 25, 2019**

(54) **ELECTRONIC CONNECTOR WITH MAGNETIC ELEMENT AND DATA TRANSMISSION LINE USING SAME**  
(71) Applicant: **Shenzhen Tongyin Hai Precision Electronics Co., Ltd.**, Shenzhen, Guangdong (CN)  
(72) Inventor: **Yinyin Wang**, Guangdong (CN)  
(\* ) Notice: Subject to any disclaimer, the term of this patent is extended or adjusted under 35 U.S.C. 154(b) by 0 days.

|                   |         |          |       |              |
|-------------------|---------|----------|-------|--------------|
| 9,515,442 B2 *    | 12/2016 | Cymerman | ..... | H01R 31/06   |
| 9,979,138 B1 *    | 5/2018  | Chen     | ..... | H01R 13/7137 |
| 9,991,628 B2 *    | 6/2018  | Daoura   | ..... | H01R 13/6205 |
| 9,991,657 B2 *    | 6/2018  | Powers   | ..... | H01R 31/06   |
| 10,069,265 B2 *   | 9/2018  | Wu       | ..... | H01R 31/06   |
| 10,096,932 B2 *   | 10/2018 | Chang    | ..... | H01R 13/74   |
| 2010/0144164 A1 * | 6/2010  | Wang     | ..... | H01R 13/6205 |
|                   |         |          |       | 439/39       |
| 2013/0189855 A1 * | 7/2013  | Lai      | ..... | H01R 13/625  |
|                   |         |          |       | 439/39       |
| 2015/0081944 A1 * | 3/2015  | An       | ..... | H01R 13/6205 |
|                   |         |          |       | 710/300      |
| 2015/0118868 A1 * | 4/2015  | Choi     | ..... | H01R 11/30   |
|                   |         |          |       | 439/39       |
| 2015/0244105 A1 * | 8/2015  | Peng     | ..... | H01R 13/6205 |
|                   |         |          |       | 439/39       |

(21) Appl. No.: **16/242,002**

(Continued)

(22) Filed: **Jan. 8, 2019**

Primary Examiner — Ross N Gushi

(30) **Foreign Application Priority Data**

(74) *Attorney, Agent, or Firm* — Jie Yang; Zan IP LLC

Aug. 2, 2018 (CN) ..... 2018 2 1243859 U  
Aug. 2, 2018 (CN) ..... 2018 2 1255953 U

(51) **Int. Cl.**  
**H01R 13/62** (2006.01)  
**H01R 24/62** (2011.01)  
**H01R 31/06** (2006.01)  
**H01R 11/30** (2006.01)

(57) **ABSTRACT**

An electronic connector is disclosed in the present disclosure. The electronic connector includes: a male connector; a female connector comprising: a shell; a supporting element received in the shell, and including an insertion opening and a receptacle space communicated with the insertion opening; a magnetic element received in the shell and surrounding the supporting element; a first terminal assembly and a second terminal assembly corresponding to the first terminal assembly received in the supporting element, wherein, the first terminal assembly including a plurality of first terminals, and the second terminal assembly including a plurality of second terminals, each of the first terminal extending into the receptacle space, and each of the second terminal extending into the receptacle space, and the first terminal and the corresponding second terminal forming a clamp for clamping the male connector which is inserted into receptacle space via the insertion opening.

(52) **U.S. Cl.**  
CPC ..... **H01R 13/6205** (2013.01); **H01R 11/30** (2013.01); **H01R 24/62** (2013.01); **H01R 31/065** (2013.01)

(58) **Field of Classification Search**  
CPC ..... H01R 11/30; H01R 13/6205  
See application file for complete search history.

(56) **References Cited**

U.S. PATENT DOCUMENTS

9,362,664 B2 \* 6/2016 Yen ..... H01R 13/6205  
9,515,420 B2 \* 12/2016 Daoura ..... H01R 13/6205

**17 Claims, 8 Drawing Sheets**

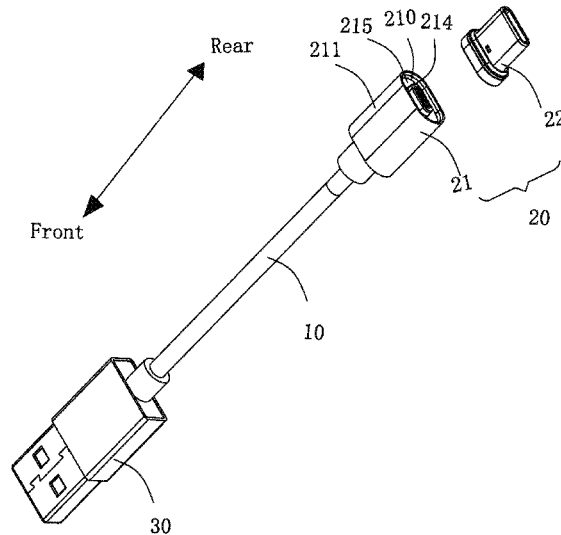

(56)

**References Cited**

U.S. PATENT DOCUMENTS

2015/0288118 A1\* 10/2015 Michelmann ..... H01R 13/502  
439/38  
2015/0364860 A1\* 12/2015 Cheng ..... H01R 13/60  
439/40  
2016/0211609 A1\* 7/2016 Sorias ..... H01R 13/6205  
2017/0085045 A1\* 3/2017 Cymerman ..... H01R 13/64  
2018/0013231 A1\* 1/2018 DiFonzo ..... H01R 13/6205  
2018/0294596 A1\* 10/2018 Zhang ..... H01R 13/24  
2018/0331468 A1\* 11/2018 Little ..... H01R 13/6205  
2018/0375251 A1\* 12/2018 Wrisley ..... H01R 13/6205  
2018/0375271 A1\* 12/2018 Powers ..... H01R 31/06  
2019/0027861 A1\* 1/2019 Brown ..... H01F 1/0317

\* cited by examiner

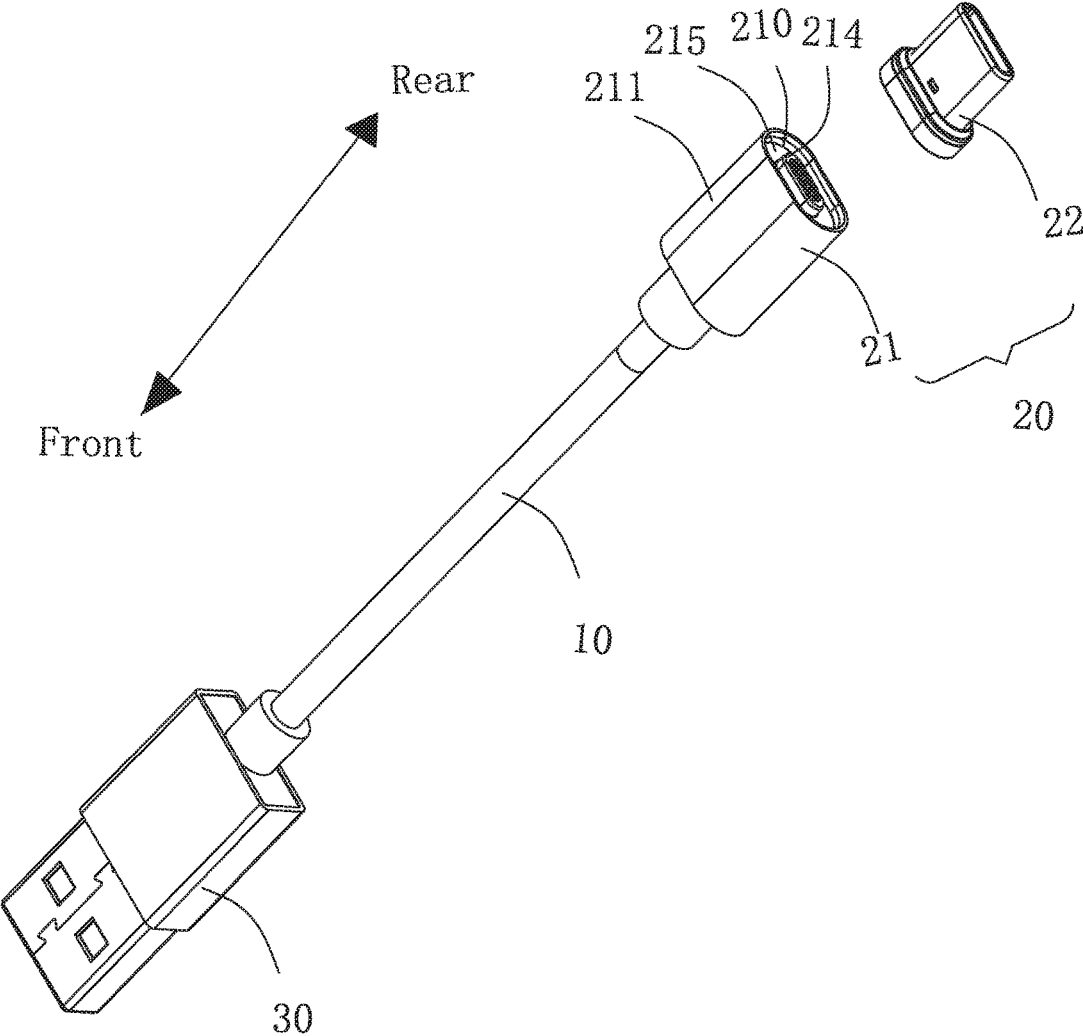

Fig. 1

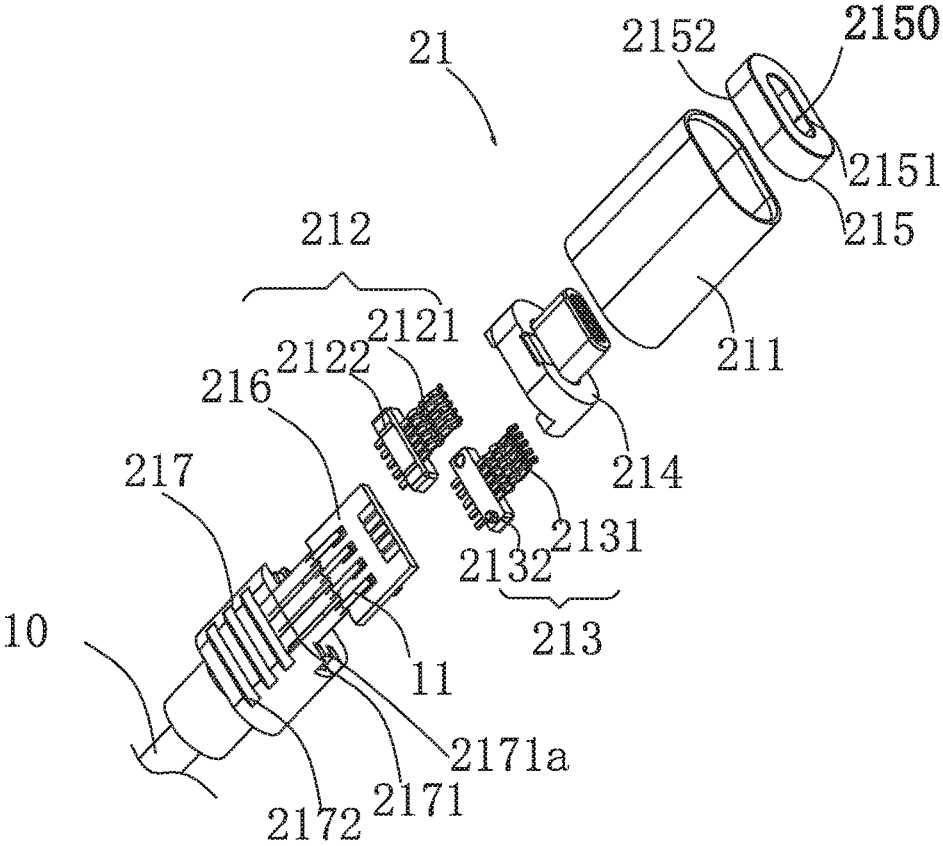

Fig. 2

214

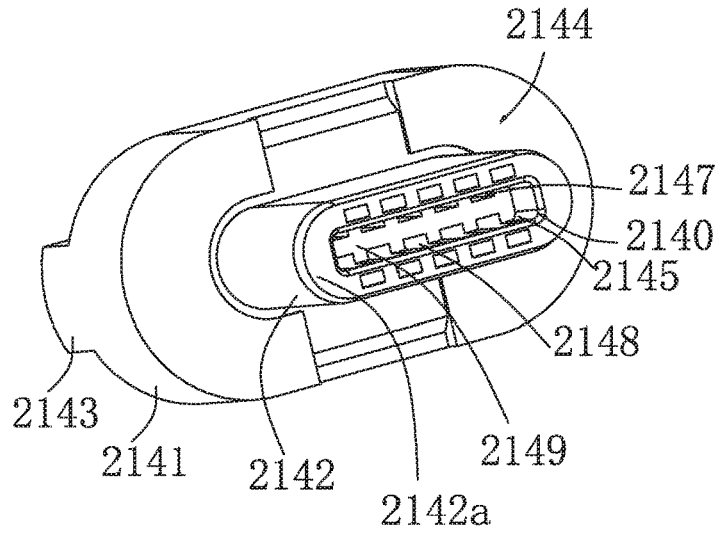

Fig. 3

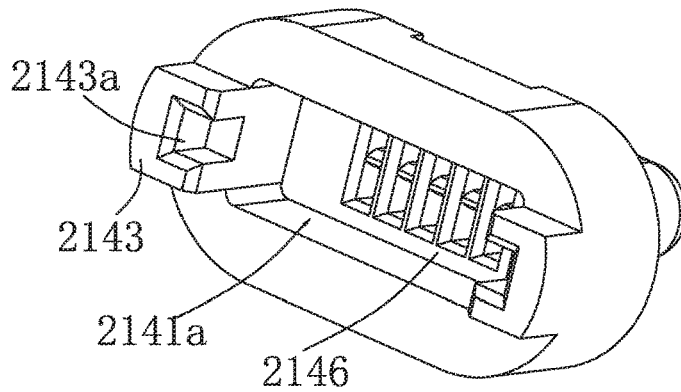

Fig. 4

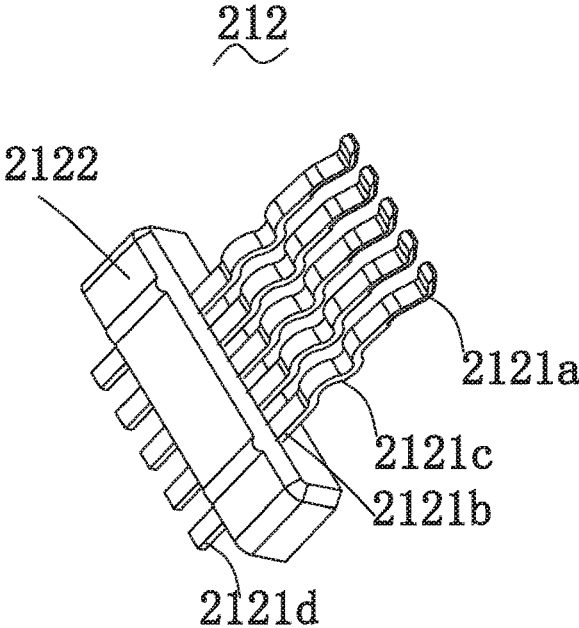

Fig. 5

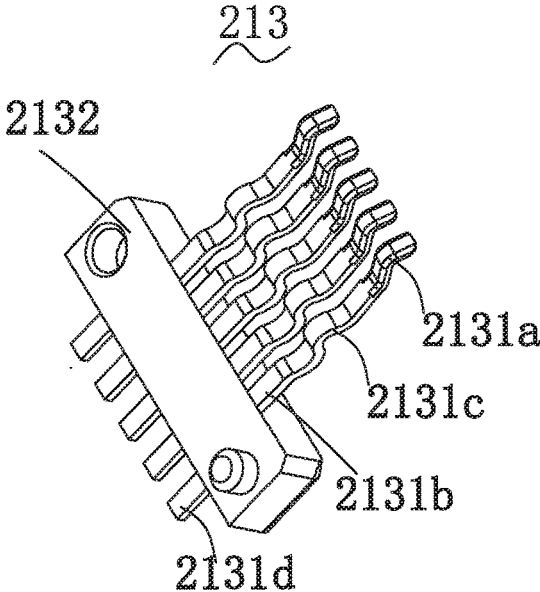

Fig. 6

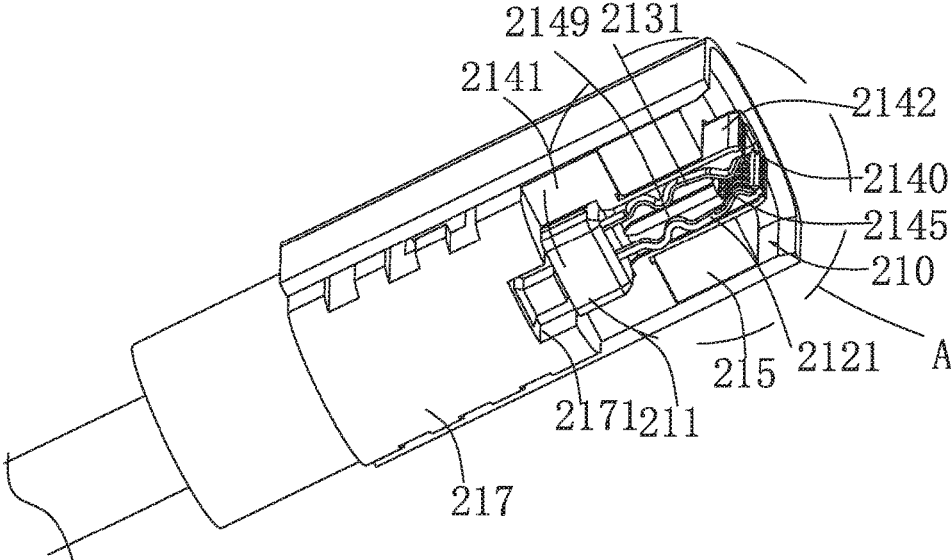

Fig. 7

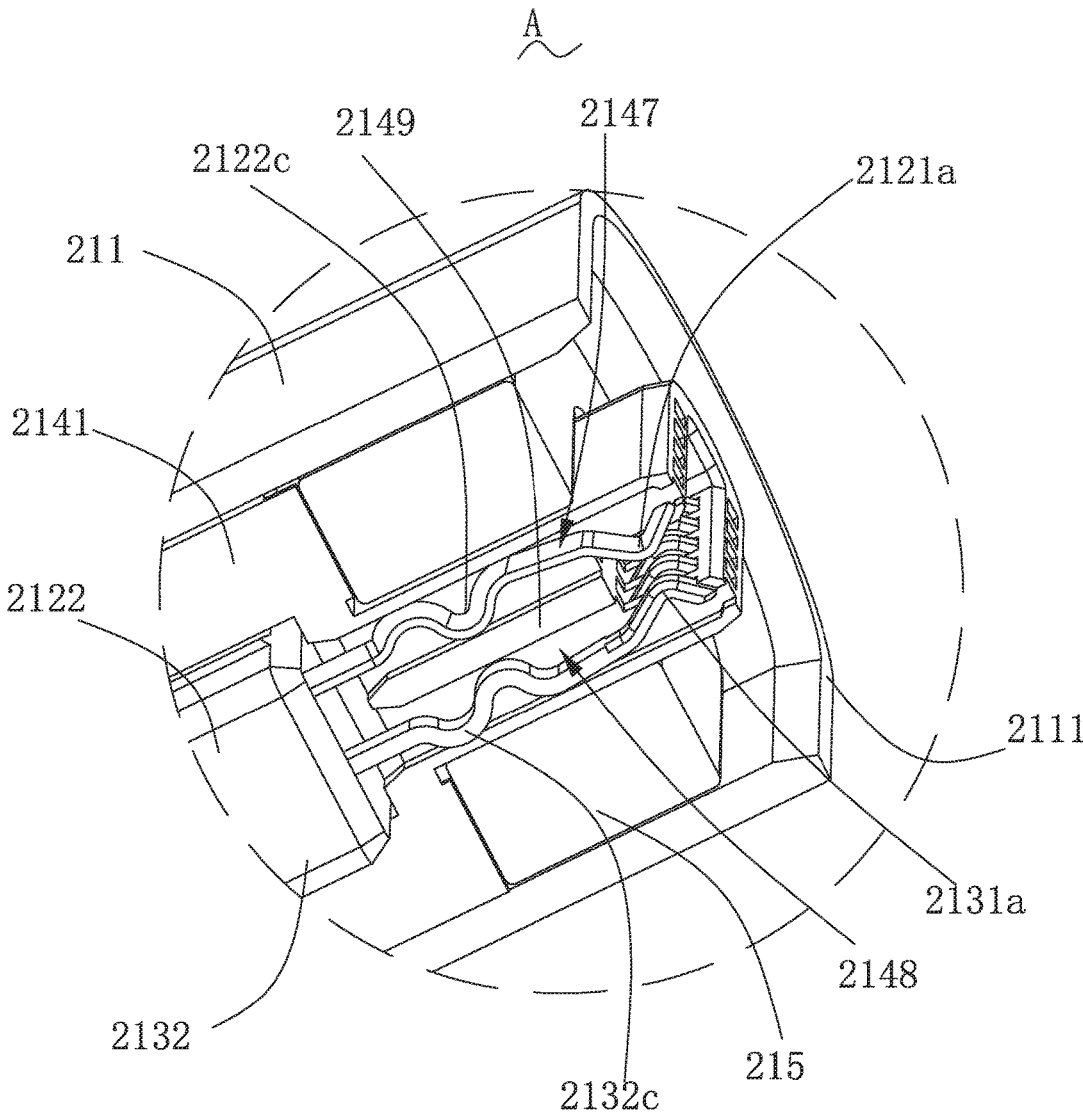

Fig. 8



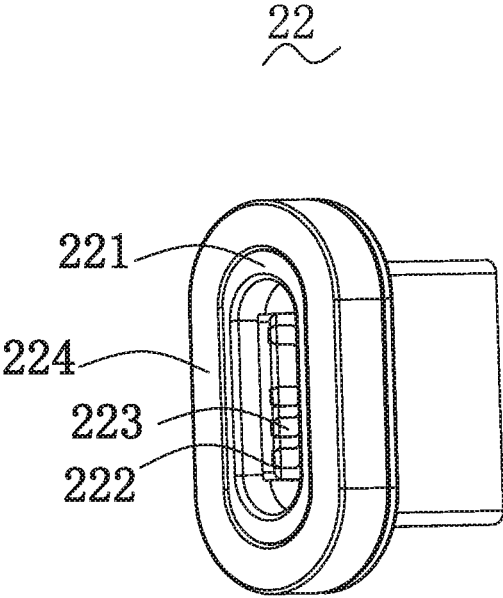

Fig. 9

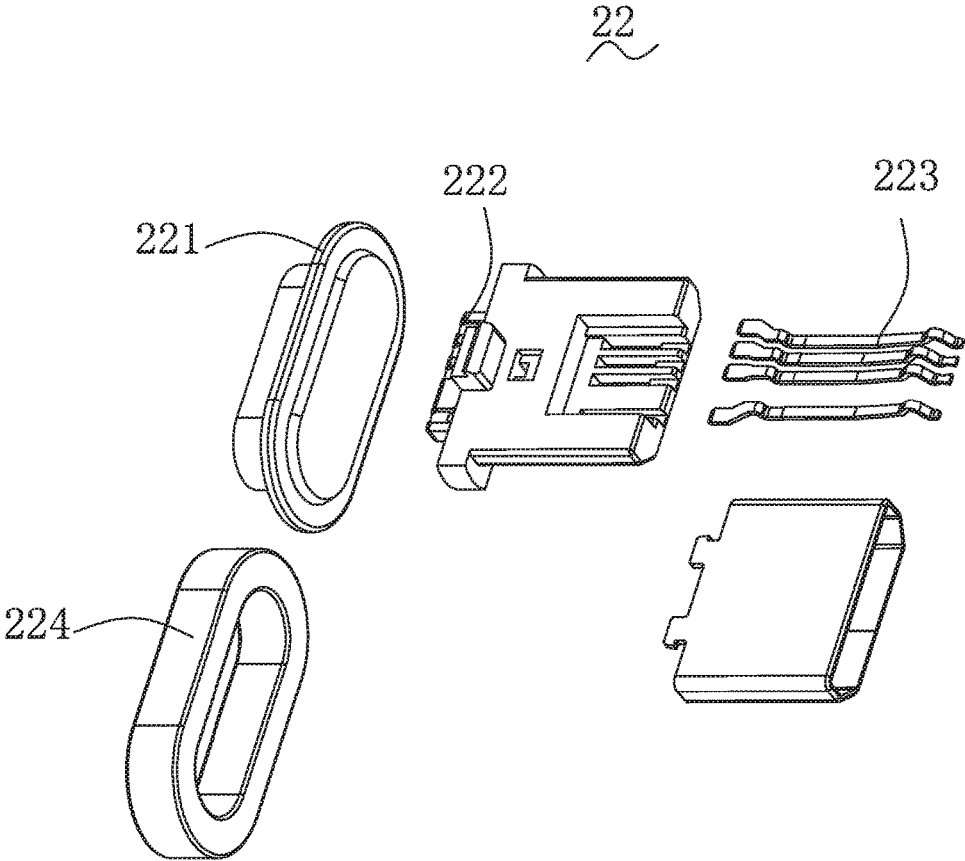

Fig. 10

1

## ELECTRONIC CONNECTOR WITH MAGNETIC ELEMENT AND DATA TRANSMISSION LINE USING SAME

### CROSS REFERENCE TO RELATED APPLICATIONS

This application claims the benefit of Chinese Application No. 201821255953.2, filed on Aug. 2, 2018, entitled “Magnetic data cable”, and Chinese Application No. 201821243859.5, filed on Aug. 2, 2018, entitled “Android Micro connector”, the contents of all of which are incorporated by reference herein in their entirety for all purposes.

### TECHNICAL FIELD

The present disclosure relates to an electronic connector, and more particularly to a electronic connector with magnetic element and a data transmission line using such electronic connector.

### BACKGROUND ART

The data transmission line used to connect existing electronic product, such as mobile phone, IPAD, and etc., generally includes a line main body and electronic connectors that are respectively provided at both ends of the line main body. When the data transmission line is used, the electronic connector of the data transmission line is frequently inserted into or removed from an interface of the mobile phone and other electronic product, such as the IPAD, repeatedly. After a long period of use, it is often easy to cause loose connections and poor contact between the electronic connector and the interface of the electronic product. In addition, at present, the electronic connector of the data transmission line can only be inserted into the interface of the electronic product in one position, and the reverse insertion cannot be realized, which brings inconvenience to the user.

### SUMMARY

In one aspect of the disclosure, an electronic connector comprises: a male connector; a female connector comprising: a shell; a supporting element received in the shell, and including an insertion opening and a receptacle space communicated with the insertion opening; a magnetic element received in the shell and surrounding the supporting element; a first terminal assembly and a second terminal assembly corresponding to the first terminal assembly received in the supporting element, wherein, the first terminal assembly including a plurality of first terminals, and the second terminal assembly including a plurality of second terminals, each of the first terminal extending into the receptacle space, and each of the second terminal extending into the receptacle space, and the first terminal and the corresponding second terminal forming a clamp for clamping the male connector which is inserted into receptacle space via the insertion opening.

In another aspect of the disclosure, an data transmission line comprises a second electronic connector; a first electronic connector comprising: a male connector; a female connector comprising: a shell; a supporting element received in the shell, and including an insertion opening and a receptacle space communicated with the insertion opening; a magnetic element received in the shell and surrounding the supporting element; a first terminal assembly and a second

2

terminal assembly corresponding to the first terminal assembly received in the supporting element, wherein, the first terminal assembly including a plurality of first terminals, and the second terminal assembly including a plurality of second terminals, each of the first terminal extending into the receptacle space, and each of the second terminal extending into the receptacle space, and the first terminal and the corresponding second terminal forming a clamp for clamping the male connector which is inserted into receptacle space via the insertion opening.

### BRIEF DESCRIPTION OF THE DRAWINGS

The above and/or additional objects, features and advantages of the present disclosure, will be further elucidated by the following illustrative and non-limiting detailed description of embodiment of the present disclosure, with reference to the appended drawings, wherein:

FIG. 1 is a perspective view of a data transmission line according to an embodiment of the present disclosure.

FIG. 2 shows an exploded view of the female connector shown in FIG. 1.

FIG. 3 and FIG. 4 show perspective view of the supporting element of the female connector shown in FIG. 2.

FIG. 5 shows a perspective view of the first terminal assembly of the female connector shown in FIG. 2.

FIG. 6 shows a perspective view of the second terminal assembly of the female connector shown in FIG. 2.

FIG. 7 shows a cross-sectional view of the female connector shown in FIG. 1.

FIG. 8 is an enlarged view of part A in FIG. 7.

FIG. 9 and FIG. 10 show a male connector of the data transmission line according to the embodiment of the present disclosure.

### DESCRIPTION OF THE PREFERRED EMBODIMENT

The present invention will be further illustrated below with reference to the attached drawings and the embodiment.

As shown in FIG. 1 through FIG. 10, a data transmission line 100 according to the embodiment includes a first electronic connector 20, a second electronic connector 30 and a cable 10 connected between the first electronic connector 20 and the second electronic connector 30. In this embodiment, the second electronic connector 30 may be an USB interface used for connecting with the interface of an electronic product, such as mobile phone, IPAD, laptop, and etc, or power supply adapter. The first electronic connector 20 may also be an interface used for connecting with the interface of other electronic product. The data transmission line 100 is used for data transmission between two electronic products that are connected via such data transmission line 100, or used to charge the electronic product.

In the embodiment, the term “front” means a forward direction toward the second connector 30, and the term “rear” means a rearward direction toward the first connector. This definition of the term is configured to help to understand the present invention instead of limiting the scope of the application.

The first connector 20 includes a female connector 21 and a male connector 22. When the first connector 20 is used, the male connector 22 is inserted into the female connector 21, with such configuration, the male connector 22 and the female connector 21 are electronically connected. The male connector 22 may be a micro USB connector, a type-C connector, or other conventional connectors. The male con-

nectors **22** are removably connected to the female connector **21**. The male connector **22** may include a first connecting assembly for connecting with the female connector **21** and electrically connected with the female connector **21**. Specifically, the first connecting assembly includes a hollow housing **221**, an insulating part **222** received in the housing **221**, a plurality of terminals **223** carried by the insulating part **222** for electrically connecting with the female connector **21**, and a magnetic element **224** surrounding the housing **221** for connecting with the female connector **21** by means of magnetic attraction.

The female connector **21** includes a hollow shell **211**, a first terminal assembly **212**, a second terminal assembly **213**, a supporting element **214** for supporting the first terminal assembly **212** and the second terminal assembly **213**, and a magnetic element **215**. The first terminal assembly **212**, the second terminal assembly **213**, the supporting element **214** and the magnetic element **215** are received in the hollow shell **211**. Preferably, the hollow shell **211** has a substantially elliptical column shape and may be made of metallic material. The supporting element **214** may be made of insulating material.

The supporting element **214** is received in the hollow shell **211** and has a T shape. The supporting element **214** includes a base body **2141**, a first extending part **2142** extending from the base body **2141** and a pair of second extending parts **2143** extending from the base body **2141** in a direction away from the first extending part **2142**. A step portion **2144** is formed between the base body **2141** and the first extending part **2142**, as the thickness of the first extending part **2142** is lower than that of the base body **2141**. The base body **2141** defines an accommodating space **2141a**. The second extending part **2143** has a first position groove **2143a**.

The first extending part **2142** has an insertion opening **2140** and a receptacle space **2145** communicated with the insertion opening **2140**. The first extending part **2142** further includes an inner part **2146** located before the receptacle space **2145**. The inner part **2146** has a plurality of first terminal grooves **2147** communicated with the receptacle space **2145**, a plurality of second terminal grooves **2148** communicated with the receptacle space **2145** and an insulating plate **2149** configured to separate the first terminal groove **2147** and the second terminal groove **2148**. The first terminal groove **2147** is close to the upper side of the first extending part **2142**, and the second terminal groove **2148** is close to the lower side of the first extending part **2142**. The first terminal grooves **2147** correspond to the second terminal grooves **2148** one by one. The first terminal grooves **2147** and the second terminal grooves **2148** communicate the accommodating space **2141a** to the receptacle space **2145**.

The first terminal assembly **212** includes a plurality of first terminals **2121** and a first combining block **2122** assembled with the first terminals **2121**. Each of the first terminal **2121** includes a first contact portion **2121a**, a first fixing portion **2121b** assembled with the first combining block **2122**, a first connecting portion **2121c** connected between the first contact portion **2121a** and the first fixing portion **2121b**, and a first extending portion **2121d** extending from the first fixing portion **2121b** in a direction away from the first contact portion **2121a**. The first contact portion **2121a** has a curved profile. The first connecting portion **2121c** also has a wavy shaped profile. Each of the first terminal **2121** may be made of elastic electric conducting material. The first combining block **2122** may be made of plastic material.

The second terminal assembly **213** includes a plurality of second terminals **2131** and a second combining block **2132** assembled with the first terminals **2131**. Each of the second terminal **2131** includes a second contact portion **2131a**, a second fixing portion **2131b** assembled with the second combining block **2132**, a second connecting portion **2131c** connected between the second contact portion **2131a** and the second fixing portion **2131b**, and a second extending portion **2131d** extending from the second fixing portion **2131b** in a direction away from the second contact portion **2131a**. The second contact portion **2131a** has a curved profile. The second connecting portion **2131c** also has a wavy shaped profile. Each of the second terminal **2131** may be made of elastic electric conducting material. The second combining block **2132** may be made of plastic material.

The magnetic element **215** may be a permanent magnet or an electromagnet. The magnetic element **215** is substantially oval shaped and has a through hole **2150** formed in the center thereof.

When assembled, the first combining block **2122** is assembled with the second combining block **2132** so that the first terminal assembly **212** is connected with the second terminal assembly **213**. Then, the first combining block **2122** and the second combining block **2132** are mounted into the accommodating space **2141a** of the base body **2141**; the first terminals **2121** and the second terminals **2131** are received in the first terminal grooves **2147** and the second terminal grooves **2148** respectively, and the first contact portions **2121a** of the first terminals **2121** and the second contact portions **2131a** of the second terminals **2131** extend into the receptacle space **2145** to form a clamp for clamping the male connector **22** which is inserted into the receptacle space **2145** via the insertion opening **2140**. The first contact portions **2121a** correspond to the second contact portions **2131a**, and the first contact portions **2121a** have a curved profile that may be curved inward, and the corresponding second contact portions **2131a** also have a curved portion that may be curved outward. The first connection portion **2121c** has a wavy shape and the corresponding second connection portion **2131c** also has a wavy shape which protrudes in an opposite direction, thus, the first connecting portion **2121c** and the second connection portion **2131c** form a clamp for clamping the insulating plate **2149**. A rear end surface **2111** of the shell is flush with the rear end surface **2142a** of the first extending part **2142**.

The first extending part **2141** passes through the through hole **2150** of the magnetic element **215**, and the magnetic element **215** is mounted on the step portion **2144**. The magnetic element **215** surrounds the outside of the supporting element **214** and is received in the shell **211**. A front end surface **2152** of the magnetic element **215** abuts against the base body **2141**, and a rear end surface **2151** of the magnetic element **215** is more closer to the base body **2141** than the rear end surface **2142a** of the first extending part **2142** so that a receiving groove **210** is formed by the magnetic element **215** incorporated with the shell **211** and the first extending part **2142**. The receiving groove **210** is configured for receiving a part of the male connector **22** while the male connector **22** is inserted into the female connector **21**.

The female connector **21** further includes a PCB **216** received in the shell **211**. The first extending portions **2121d** of the first terminals **2121** and the second extending portions **2131d** of the second terminals **2131** are connected with such PCB **216** respectively for data transmission.

The female connector **21** further includes a fixing element **217** for connecting the cable **10** to the first electronic connector **20**. Specifically, the fixing element **217** is config-

5

ured for holding wires **11** of the cable **10**. The wires **11** are connected with the PCB **216**. The fixing element **217** has a pair of second position grooves **2171** formed in a rearward surface thereof for receiving the second extending part **2143** of the support element **214**. Specifically, a protruding part **2171a** is formed in the position groove **2171**, which is received in the first position groove **2143a** while the second extending part **2143** inserted into the second position groove **2171**.

The description in more detail aims to help to understand the present invention, instead of limiting the present invention. According to the contents disclosed by the present invention, those skilled in the art shall understand that the present invention can be implemented even without some or all of these specific details. Under other circumstances, to avoid weakening the inventiveness of the present invention, the well-known circuits, methods, operation processes and the like will not be described in detail.

What is claimed is:

**1.** An electronic connector, comprising:  
 a male connector;  
 a female connector comprising:  
 a shell;  
 a supporting element received in the shell, and including an insertion opening and a receptacle space communicated with the insertion opening;  
 a magnetic element received in the shell and surrounding the supporting element;  
 a first terminal assembly and a second terminal assembly corresponding to the first terminal assembly received in the supporting element, wherein, the first terminal assembly including a plurality of first terminals, and the second terminal assembly including a plurality of second terminals, each of the first terminal extending into the receptacle space, and each of the second terminal extending into the receptacle space, and the first terminal and the corresponding second terminal forming a clamp for clamping the male connector which is inserted into receptacle space via the insertion opening.

**2.** The electronic connector of claim **1**, wherein, the female connector further comprise a PCB, the PCB is connected to the first terminals and the second terminals, and the PCB is received in the shell.

**3.** The electronic connector of claim **1**, wherein, the supporting element comprises a base body and a first extending part extending from the base body; the insertion opening is defined in a rear end surface of the first extending part and the receptacle space is defined in an inner of the first extending part.

**4.** The electronic connector of claim **3**, wherein, the magnetic element surrounds the first extending part, and a front end surface of the magnetic element abuts against the base body and a rear end surface of the magnetic element is more closer to the base body than that of the first extending part, so that a receiving groove is formed by the magnetic element incorporated with the first extending part and the shell.

**5.** The electronic connector of claim **4**, wherein, a rear end surface of the shell is flush with the front surface of the first extending part.

**6.** The electronic connector of claim **3**, wherein, the first extending part includes a plurality of first terminal grooves formed on an upper side thereof for receiving the first terminals, a plurality of second terminal grooves formed on a lower side thereof for receiving the second terminals, and an insulated plate formed between the first terminal grooves and the second terminal grooves for separating the first

6

terminal grooves and the second terminal grooves; the first terminal grooves and the second terminal grooves are communicated with the receptacle space.

**7.** The electronic connector of claim **6**, wherein, each of the first terminals comprises a first contact portion, a first fixing portion, a first connecting portion connected between the first contact portion and the first fixing portion, and a first extending portion extending from the first fixing portion in a direction opposite to the first contact portion; the first connecting portion has a wavy shape;

each of the second terminals comprises a second contact portion, a second fixing portion, a second connecting portion connected between the second contact portion and the second fixing portion and a second extending portion extending from the second fixing portion in a direction opposite to the second contact portion; the second connecting portion has a wavy shape;

the second connecting portion received in the second terminal groove and the corresponding first connecting portion received in the first terminal groove forms a clamp for clamping the insulated plate.

**8.** A data transmission line, comprising:

a first electronic connector comprising:

a male connector;

a female connector comprising:

a shell;

a supporting element received in the shell, and including an insertion opening and a receptacle space communicated with the insertion opening;

a magnetic element received in the shell and surrounding the supporting element;

a first terminal assembly and a second terminal assembly corresponding to the first terminal assembly received in the supporting element, wherein, the first terminal assembly including a plurality of first terminals, and the second terminal assembly including a plurality of second terminals, each of the first terminal extending into the receptacle space, and each of the second terminal extending into the receptacle space, and the first terminal and the corresponding second terminal forming a clamp for clamping the male connector which is inserted into receptacle space via the insertion opening;

a second electronic connector; and

a cable connected between the first electronic connector and the second electronic connector.

**9.** The data transmission line of claim **8**, wherein, the female connector further comprise a PCB received in the shell, the PCB is connected to the first terminals and the second terminals and wires of the cable respectively.

**10.** The data transmission line of claim **8**, wherein, the female connector further comprises a fixing element for holding wires of the cable, the fixing element is received in the shell and connected with the supporting element.

**11.** The data transmission line of claim **10**, wherein, the supporting element comprises a base body, a first extending part extending from the base body, and a pair of second extending parts extending from the base body in a direction opposite to the first extending part; the insertion opening is defined in a rear end surface of the first extending part and the receptacle space is defined in an inner of the first extending part.

**12.** The data transmission line of claim **11**, wherein, the fixing element includes a pair of second position groove formed in a rear surface of the fixing element for receiving the second extending parts respectively so that the fixing element is fixed to the supporting element.

13. The data transmission line of claim 12, wherein, each of the second extending parts includes a first position groove, and the fixing element further includes a pair of protruding parts, each of the protruding parts formed in the second position groove corresponding to the first position groove so that the protruding part receives in the first position groove.

14. The data transmission line of claim 11, wherein, the magnetic element surrounds the first extending part, and a front end surface of the magnetic element abuts against the base body and a rear end surface of the magnetic element is more closer to the base body than that of the first extending part, so that a receiving groove is formed by the magnetic element incorporated with the first extending part and the shell.

15. The data transmission line of claim 11, wherein, a rear end surface of the shell is flush with the rear end surface of the first extending part.

16. The data transmission line of claim 15, wherein, each of the first terminals comprises a first contact portion, a first fixing portion, a first connecting portion connected between the first contact portion and the first fixing portion, and a first extending portion extending from the first fixing portion in

a direction opposite to the first contact portion; the first connecting portion has a wavy shape;

each of the second terminals comprises a second contact portion, a second fixing portion, a second connecting portion connected between the second contact portion and the second fixing portion and a second extending portion extending from the second fixing portion in a direction opposite to the second contact portion; the second connecting portion has a wavy shape;

the second connecting portion received in the second terminal groove and the corresponding first connecting portion received in the first terminal groove forms a clamp for clamping the insulated plate.

17. The data transmission line of claim 11, wherein, the first extending part includes a plurality of first terminal grooves formed on an upper side thereof for receiving the first terminals, a plurality of second terminal grooves formed on a lower side thereof for receiving the second terminal grooves, and an insulated plate formed between the first terminal grooves and the second terminal grooves for separating the first terminal grooves and the second terminal grooves; the first terminal grooves and the second terminal grooves are communicated with the receptacle space.

\* \* \* \* \*