



US010359659B2

(12) **United States Patent**
Dunn et al.

(10) **Patent No.:** **US 10,359,659 B2**

(45) **Date of Patent:** **Jul. 23, 2019**

(54) **COOLING SYSTEM FOR ELECTRONIC DISPLAY**

(71) Applicant: **Manufacturing Resources International, Inc.**, Alpharetta, GA (US)

(72) Inventors: **William Dunn**, Alpharetta, GA (US); **Kevin O'Connor**, Duluth, GA (US)

(73) Assignee: **MANUFACTURING RESOURCES INTERNATIONAL, INC.**, Alpharetta, GA (US)

(*) Notice: Subject to any disclaimer, the term of this patent is extended or adjusted under 35 U.S.C. 154(b) by 0 days.

(21) Appl. No.: **16/114,049**

(22) Filed: **Aug. 27, 2018**

(65) **Prior Publication Data**
US 2018/0364519 A1 Dec. 20, 2018

Related U.S. Application Data

(63) Continuation of application No. 15/289,563, filed on Oct. 10, 2016, now Pat. No. 10,088,702, which is a (Continued)

(51) **Int. Cl.**
G06F 1/16 (2006.01)
H05K 5/00 (2006.01)
(Continued)

(52) **U.S. Cl.**
CPC ... **G02F 1/133382** (2013.01); **H05K 7/20972** (2013.01); **G02F 1/133385** (2013.01); **G02F 2201/36** (2013.01)

(58) **Field of Classification Search**
CPC ... G06F 1/1601; G06F 1/1616; G06F 1/1618; G06F 1/162; G06F 1/1622; G06F 1/1624; (Continued)

(56) **References Cited**
U.S. PATENT DOCUMENTS

4,093,355 A 6/1978 Kaplit et al.
4,593,978 A 6/1986 Mourey et al.
(Continued)

FOREIGN PATENT DOCUMENTS

AU 2011248190 B2 5/2011
AU 2014287438 B2 1/2018
(Continued)

OTHER PUBLICATIONS

Itsenclosures, Product Catalog, 2009, 48 pages.
(Continued)

Primary Examiner — Anthony M Houghton
(74) *Attorney, Agent, or Firm* — Standley Law Group LLP; Jeffrey S. Standley; Adam J. Smith

(57) **ABSTRACT**

A cooling assembly for an electronic display includes a front channel that passes in front of the viewable area of the electronic display. A center channel is located behind the electronic display. A rear channel is located behind the second channel. A first plurality of subchannels are located within the center channel and connect only to the front channel. A second plurality of subchannels are located within the center channel and connect only to the rear channel.

20 Claims, 7 Drawing Sheets

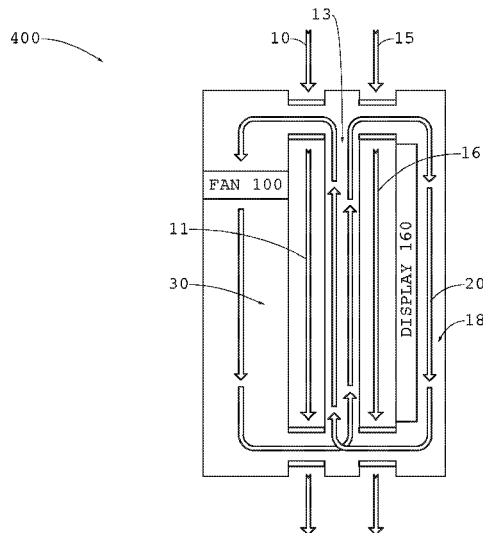

Related U.S. Application Data

- continuation of application No. 14/326,059, filed on Jul. 8, 2014, now Pat. No. 9,470,924.
- (60) Provisional application No. 61/843,706, filed on Jul. 8, 2013.
- (51) **Int. Cl.**
H05K 7/00 (2006.01)
G02F 1/1333 (2006.01)
H05K 7/20 (2006.01)
- (58) **Field of Classification Search**
 CPC G06F 1/1628; G06F 1/163; G06F 1/1633;
 G06F 1/169; G06F 1/1643; G06F 1/20;
 G06F 1/203; G06F 1/206; H05K 7/20972;
 G02F 1/133382
 USPC 361/679.21-679.3, 679.55, 679.56,
 361/692-695, 679.4-679.44, 679.37,
 361/679.48-679.51
 See application file for complete search history.

(56) **References Cited**

U.S. PATENT DOCUMENTS

4,634,225 A 1/1987 Haim et al.
 4,748,765 A 6/1988 Martin
 4,763,993 A 8/1988 Vogeley et al.
 4,921,041 A 5/1990 Akachi
 4,952,783 A 8/1990 Aufderheide et al.
 4,952,925 A 8/1990 Haastert
 5,029,982 A 7/1991 Nash
 5,088,806 A 2/1992 McCartney et al.
 5,132,666 A 7/1992 Fahs
 5,247,374 A 9/1993 Terada
 5,282,114 A 1/1994 Stone
 5,293,930 A 3/1994 Pitasi
 5,351,176 A 9/1994 Smith et al.
 5,432,526 A 7/1995 Hyatt
 5,535,816 A 7/1996 Ishida
 5,559,614 A 9/1996 Urbish et al.
 5,621,614 A 4/1997 O'Neill
 5,657,641 A 8/1997 Cunningham et al.
 5,748,269 A 5/1998 Harris et al.
 5,765,743 A 6/1998 Sakiura et al.
 5,767,489 A 6/1998 Ferrier
 5,808,418 A 9/1998 Pitman et al.
 5,818,010 A 10/1998 McCann
 5,818,694 A 10/1998 Daikoku et al.
 5,835,179 A 11/1998 Yamanaka
 5,864,465 A 1/1999 Liu
 5,869,818 A 2/1999 Kim
 5,869,919 A 2/1999 Sato et al.
 5,903,433 A 5/1999 Gudmundsson
 5,991,153 A 11/1999 Heady et al.
 6,003,015 A 12/1999 Kang et al.
 6,007,205 A 12/1999 Fujimori
 6,089,751 A 7/2000 Conover et al.
 6,104,451 A 8/2000 Matsuoka et al.
 6,125,565 A 10/2000 Hillstrom
 6,157,432 A 12/2000 Helbing
 6,181,070 B1 1/2001 Dunn et al.
 6,191,839 B1 2/2001 Briley et al.
 6,198,222 B1 3/2001 Chang
 6,211,934 B1 4/2001 Habing et al.
 6,215,655 B1 4/2001 Heady et al.
 6,351,381 B1 2/2002 Bilski et al.
 6,392,727 B1 5/2002 Larson et al.
 6,417,900 B1 7/2002 Shin et al.
 6,428,198 B1 8/2002 Saccomanno et al.
 6,473,150 B1 10/2002 Takushima et al.
 6,493,440 B2 12/2002 Gromatsky et al.
 6,504,713 B1 1/2003 Pandolfi et al.
 6,535,266 B1 3/2003 Nemeth et al.
 6,628,355 B1 9/2003 Takahara

6,701,143 B1 3/2004 Dukach et al.
 6,714,410 B2 3/2004 Wellhofer
 6,727,468 B1 4/2004 Nemeth
 6,812,851 B1 11/2004 Dukach et al.
 6,825,828 B2 11/2004 Burke et al.
 6,839,104 B2 1/2005 Taniguchi et al.
 6,850,209 B2 2/2005 Mankins et al.
 6,885,412 B2 4/2005 Ohnishi et al.
 6,886,942 B2 5/2005 Okada et al.
 6,891,135 B2 5/2005 Pala et al.
 6,909,486 B2 6/2005 Wang et al.
 6,943,768 B2 9/2005 Cavanaugh et al.
 6,961,108 B2 11/2005 Wang et al.
 7,015,470 B2 3/2006 Faytlin et al.
 7,059,757 B2 6/2006 Shimizu
 7,083,285 B2 8/2006 Hsu et al.
 7,157,838 B2 1/2007 Thielemans et al.
 7,161,803 B1 1/2007 Heady
 7,190,416 B2 3/2007 Paukshto et al.
 7,190,587 B2 3/2007 Kim et al.
 7,209,349 B2 4/2007 Chien et al.
 7,212,403 B2 5/2007 Rockenfeller
 7,259,964 B2 8/2007 Yamamura et al.
 7,269,023 B2 9/2007 Nagano
 7,284,874 B2 10/2007 Jeong et al.
 7,452,121 B2 11/2008 Cho et al.
 7,457,113 B2 11/2008 Kumhyr et al.
 7,480,140 B2 1/2009 Hara et al.
 7,535,543 B2 5/2009 Dewa et al.
 7,591,508 B2 9/2009 Chang
 7,602,469 B2 10/2009 Shin
 D608,775 S 1/2010 Leung
 7,667,964 B2 2/2010 Kang et al.
 7,682,047 B2 3/2010 Hsu et al.
 7,752,858 B2 7/2010 Johnson et al.
 7,753,567 B2 7/2010 Kang et al.
 7,800,706 B2 9/2010 Kim et al.
 7,813,124 B2 10/2010 Karppanen
 7,903,416 B2 3/2011 Chou
 7,995,342 B2 8/2011 Nakamichi et al.
 8,004,648 B2 8/2011 Dunn
 8,035,968 B2 10/2011 Kwon et al.
 8,081,465 B2 12/2011 Nishiura
 8,102,173 B2 1/2012 Merrow
 8,142,027 B2 3/2012 Sakai
 8,208,115 B2 6/2012 Dunn
 8,223,311 B2 7/2012 Kim et al.
 8,241,573 B2 8/2012 Banerjee et al.
 8,248,784 B2 8/2012 Nakamichi et al.
 8,254,121 B2 8/2012 Lee et al.
 8,269,916 B2 9/2012 Ohkawa
 8,270,163 B2 9/2012 Nakamichi et al.
 8,274,622 B2 9/2012 Dunn
 8,274,789 B2 9/2012 Nakamichi et al.
 8,300,203 B2 10/2012 Nakamichi et al.
 8,320,119 B2 11/2012 Isoshima et al.
 8,351,014 B2 1/2013 Dunn
 8,358,397 B2 1/2013 Dunn
 8,369,083 B2 2/2013 Dunn et al.
 8,373,841 B2 2/2013 Dunn
 8,379,182 B2 2/2013 Dunn
 8,400,608 B2 3/2013 Takahashi et al.
 8,472,174 B2 6/2013 Idems et al.
 8,472,191 B2 6/2013 Yamamoto et al.
 8,482,695 B2 7/2013 Dunn
 8,497,972 B2 7/2013 Dunn et al.
 8,590,602 B2 11/2013 Fernandez
 8,649,170 B2 2/2014 Dunn et al.
 8,649,176 B2 2/2014 Okada et al.
 8,654,302 B2 2/2014 Dunn et al.
 8,678,603 B2 3/2014 Zhang
 8,693,185 B2 4/2014 Dunn et al.
 8,700,226 B2 4/2014 Schuch et al.
 8,711,321 B2 4/2014 Dunn et al.
 8,749,749 B2 6/2014 Hubbard
 8,755,021 B2 6/2014 Hubbard
 8,758,144 B2 6/2014 Williams et al.
 8,760,613 B2 6/2014 Dunn
 8,767,165 B2 7/2014 Dunn

(56)

References Cited

U.S. PATENT DOCUMENTS

8,773,633	B2	7/2014	Dunn et al.	2005/0134525	A1	6/2005	Tanghe et al.
8,804,091	B2	8/2014	Dunn et al.	2005/0134526	A1	6/2005	Willem et al.
8,823,916	B2	9/2014	Hubbard et al.	2005/0213950	A1	9/2005	Yoshimura
8,827,472	B2	9/2014	Takada	2005/0229630	A1	10/2005	Richter et al.
8,854,572	B2	10/2014	Dunn	2005/0237714	A1	10/2005	Ebermann
8,854,595	B2	10/2014	Dunn	2005/0276053	A1	12/2005	Nortrup et al.
8,879,042	B2	11/2014	Dunn	2005/0286131	A1	12/2005	Saxena et al.
8,988,647	B2	3/2015	Hubbard	2006/0012958	A1	1/2006	Tomioka et al.
9,030,641	B2	5/2015	Dunn	2006/0018093	A1	1/2006	Lai et al.
9,089,079	B2	7/2015	Dunn	2006/0034051	A1	2/2006	Wang et al.
9,119,325	B2	8/2015	Dunn et al.	2006/0056994	A1	3/2006	Van Lear et al.
9,119,330	B2	8/2015	Hubbard et al.	2006/0082271	A1	4/2006	Lee et al.
9,173,322	B2	10/2015	Dunn	2006/0092348	A1	5/2006	Park
9,173,325	B2	10/2015	Dunn	2006/0125998	A1	6/2006	Dewa et al.
9,282,676	B1	3/2016	Diaz	2006/0132699	A1	6/2006	Cho et al.
9,285,108	B2	3/2016	Dunn et al.	2006/0177587	A1	8/2006	Ishizuka et al.
9,313,917	B2	4/2016	Dunn et al.	2006/0199514	A1	9/2006	Kimura
9,370,127	B2	6/2016	Dunn	2006/0209266	A1	9/2006	Utsunomiya
9,448,569	B2	9/2016	Schuch et al.	2006/0260790	A1	11/2006	Theno et al.
9,451,060	B1	9/2016	Bowers et al.	2006/0262079	A1	11/2006	Seong et al.
9,451,733	B2	9/2016	Dunn et al.	2006/0266499	A1	11/2006	Choi et al.
9,456,525	B2	9/2016	Yoon et al.	2006/0283579	A1	12/2006	Ghosh et al.
9,470,924	B2	10/2016	Dunn et al.	2007/0013647	A1	1/2007	Lee et al.
9,500,896	B2	11/2016	Dunn et al.	2007/0019419	A1	1/2007	Hafuka et al.
9,516,485	B1	12/2016	Bowers et al.	2007/0030879	A1	2/2007	Hatta
9,549,490	B2	1/2017	Hubbard	2007/0047239	A1	3/2007	Kang et al.
9,594,271	B2	3/2017	Dunn et al.	2007/0065091	A1	3/2007	Hinata et al.
9,613,548	B2	4/2017	DeMars	2007/0076431	A1	4/2007	Atarashi et al.
9,622,392	B1	4/2017	Bowers et al.	2007/0103863	A1	5/2007	Kim
9,629,287	B2	4/2017	Dunn	2007/0103866	A1	5/2007	Park
9,648,790	B2	5/2017	Dunn et al.	2007/0115686	A1	5/2007	Tyberghien
9,655,289	B2	5/2017	Dunn et al.	2007/0139929	A1	6/2007	Yoo et al.
9,703,230	B2	7/2017	Bowers et al.	2007/0140671	A1	6/2007	Yoshimura
9,723,765	B2	8/2017	DeMars	2007/0151274	A1	7/2007	Roche et al.
9,797,588	B2	10/2017	Dunn et al.	2007/0151664	A1	7/2007	Shin
9,801,305	B2	10/2017	Dunn et al.	2007/0171353	A1	7/2007	Hong
9,823,690	B2	11/2017	Bowers et al.	2007/0206158	A1	9/2007	Kinoshita et al.
9,835,893	B2	12/2017	Dunn	2007/0211205	A1	9/2007	Shibata
9,894,800	B2	2/2018	Dunn	2007/0212211	A1	9/2007	Chiyoda et al.
2001/0001459	A1	5/2001	Savant et al.	2007/0217221	A1	9/2007	Lee et al.
2001/0019454	A1	9/2001	Tadic-Galeb et al.	2007/0237636	A1	10/2007	Hsu
2002/0009978	A1	1/2002	Dukach et al.	2007/0267174	A1	11/2007	Kim
2002/0033919	A1	3/2002	Sanelle et al.	2008/0055534	A1	3/2008	Kawano
2002/0050793	A1	5/2002	Cull et al.	2008/0076342	A1	3/2008	Bryant et al.
2002/0065046	A1	5/2002	Mankins et al.	2008/0099193	A1	5/2008	Aksamit et al.
2002/0084891	A1	7/2002	Mankins et al.	2008/0148609	A1	6/2008	Ogoreve
2002/0101553	A1	8/2002	Enomoto et al.	2008/0209934	A1	9/2008	Richards
2002/0112026	A1	8/2002	Fridman et al.	2008/0218446	A1	9/2008	Yamanaka
2002/0126248	A1	9/2002	Yoshia	2008/0236005	A1	10/2008	Isayev et al.
2002/0148600	A1	10/2002	Bosch et al.	2008/0267790	A1	10/2008	Gaudet et al.
2002/0149714	A1	10/2002	Anderson et al.	2008/0283234	A1	11/2008	Sagi et al.
2002/0154255	A1	10/2002	Gromatzky et al.	2008/0285290	A1	11/2008	Ohashi et al.
2002/0164944	A1	11/2002	Haglid	2008/0310116	A1	12/2008	O'Connor
2002/0164962	A1	11/2002	Mankins et al.	2009/0009047	A1	1/2009	Yanagawa et al.
2002/0167637	A1	11/2002	Burke et al.	2009/0009729	A1	1/2009	Sakai
2003/0007109	A1	1/2003	Park	2009/0059518	A1	3/2009	Kakikawa et al.
2003/0020884	A1	1/2003	Okada et al.	2009/0065007	A1	3/2009	Wilkinson et al.
2003/0043091	A1	3/2003	Takeuchi et al.	2009/0086430	A1	4/2009	Kang et al.
2003/0104210	A1	6/2003	Azumi et al.	2009/0120629	A1	5/2009	Ashe
2003/0128511	A1	7/2003	Nagashima et al.	2009/0122218	A1	5/2009	Oh et al.
2003/0214785	A1	11/2003	Perazzo	2009/0126906	A1	5/2009	Dunn
2004/0012722	A1	1/2004	Alvarez	2009/0126907	A1	5/2009	Dunn
2004/0035032	A1	2/2004	Milliken	2009/0126914	A1	5/2009	Dunn
2004/0035558	A1	2/2004	Todd et al.	2009/0135365	A1	5/2009	Dunn
2004/0036622	A1	2/2004	Dukach et al.	2009/0147170	A1	6/2009	Oh et al.
2004/0036834	A1	2/2004	Ohnishi et al.	2009/0154096	A1	6/2009	Iyengar et al.
2004/0103570	A1	6/2004	Ruttenberg	2009/0174626	A1	7/2009	Isoshima et al.
2004/0105159	A1	6/2004	Saccomanno et al.	2009/0244472	A1	10/2009	Dunn
2004/0165139	A1	8/2004	Anderson et al.	2009/0279240	A1	11/2009	Karppanen
2004/0223299	A1	11/2004	Ghosh	2009/0302727	A1	12/2009	Vincent et al.
2005/0012039	A1	1/2005	Faytlin et al.	2009/0306820	A1	12/2009	Simmons et al.
2005/0012722	A1	1/2005	Chon	2010/0060861	A1	3/2010	Medin
2005/0062373	A1	3/2005	Kim et al.	2010/0079949	A1	4/2010	Nakamichi et al.
2005/0073632	A1	4/2005	Dunn et al.	2010/0162747	A1	7/2010	Hamel et al.
2005/0073639	A1	4/2005	Pan	2010/0171889	A1	7/2010	Pantel et al.
				2010/0182562	A1	7/2010	Yoshida et al.
				2010/0220249	A1	9/2010	Nakamichi et al.
				2010/0226091	A1	9/2010	Dunn
				2010/0232107	A1	9/2010	Dunn

(56)

References Cited

U.S. PATENT DOCUMENTS

2010/0238394 A1 9/2010 Dunn
 2010/0321887 A1 12/2010 Kwon et al.
 2011/0001898 A1 1/2011 Mikubo et al.
 2011/0013114 A1 1/2011 Dunn et al.
 2011/0019363 A1 1/2011 Vahlsing et al.
 2011/0051071 A1 3/2011 Nakamichi et al.
 2011/0058326 A1 3/2011 Idems et al.
 2011/0075361 A1 3/2011 Nakamichi et al.
 2011/0083460 A1 4/2011 Thomas et al.
 2011/0083824 A1 4/2011 Rogers
 2011/0085301 A1* 4/2011 Dunn G02F 1/133385
 361/695
 2011/0114384 A1 5/2011 Sakamoto et al.
 2011/0116000 A1 5/2011 Dunn et al.
 2011/0116231 A1 5/2011 Dunn et al.
 2011/0122162 A1 5/2011 Sato et al.
 2011/0141724 A1 6/2011 Edon
 2011/0261523 A1 10/2011 Dunn et al.
 2012/0006523 A1 1/2012 Masahiro et al.
 2012/0012295 A1 1/2012 Kakiuchi et al.
 2012/0012300 A1 1/2012 Dunn et al.
 2012/0014063 A1 1/2012 Weiss
 2012/0020114 A1 1/2012 Miyamoto et al.
 2012/0038849 A1 2/2012 Dunn et al.
 2012/0044217 A1 2/2012 Okada et al.
 2012/0106081 A1* 5/2012 Hubbard G02F 1/133308
 361/696
 2012/0188481 A1 7/2012 Kang et al.
 2012/0206687 A1 8/2012 Dunn et al.
 2012/0249402 A1 10/2012 Kang
 2012/0255704 A1 10/2012 Nakamichi
 2012/0274876 A1 11/2012 Cappaert et al.
 2012/0284547 A1 11/2012 Culbert et al.
 2013/0170140 A1 7/2013 Dunn
 2013/0173358 A1 7/2013 Pinkus
 2013/0176517 A1 7/2013 Kim et al.
 2013/0201685 A1 8/2013 Messmore et al.
 2013/0258659 A1 10/2013 Erion
 2013/0279154 A1 10/2013 Dunn
 2013/0294039 A1 11/2013 Chao
 2014/0044147 A1 2/2014 Wyatt et al.
 2014/0085564 A1 3/2014 Hendren et al.
 2014/0111758 A1 4/2014 Dunn et al.
 2014/0113540 A1 4/2014 Dunn et al.
 2014/0313698 A1 10/2014 Dunn et al.
 2014/0314395 A1 10/2014 Dunn et al.
 2015/0009627 A1 1/2015 Dunn et al.
 2015/0253611 A1 9/2015 Yang et al.
 2015/0264826 A1 9/2015 Dunn et al.
 2015/0319882 A1 11/2015 Dunn et al.
 2015/0366101 A1 12/2015 Dunn et al.
 2016/0041423 A1 2/2016 Dunn
 2016/0044829 A1 2/2016 Dunn
 2016/0192536 A1 6/2016 Diaz
 2016/0195254 A1 7/2016 Dunn et al.
 2016/0198588 A1 7/2016 DeMars
 2016/0238876 A1 8/2016 Dunn et al.
 2016/0242329 A1 8/2016 DeMars
 2016/0242330 A1 8/2016 Dunn
 2016/0249493 A1 8/2016 Dunn et al.
 2016/0302331 A1 10/2016 Dunn
 2017/0023823 A1 1/2017 Dunn et al.
 2017/0068042 A1 3/2017 Dunn et al.
 2017/0074453 A1 3/2017 Bowers et al.
 2017/0083043 A1 3/2017 Bowers et al.
 2017/0083062 A1 3/2017 Bowers et al.
 2017/0111486 A1 4/2017 Bowers et al.
 2017/0111520 A1 4/2017 Bowers et al.
 2017/0111521 A1 4/2017 Bowers et al.
 2017/0127579 A1 5/2017 Hubbard
 2017/0140344 A1 5/2017 Bowers et al.
 2017/0147992 A1 5/2017 Bowers et al.
 2017/0163519 A1 6/2017 Bowers et al.
 2017/0175411 A1 6/2017 Bowers et al.
 2017/0188490 A1 6/2017 Dunn et al.

2017/0245400 A1 8/2017 Dunn et al.
 2017/0257978 A1 9/2017 Diaz
 2017/0332523 A1 11/2017 DeMars
 2018/0042134 A1 2/2018 Dunn et al.
 2018/0116073 A1 4/2018 Dunn

FOREIGN PATENT DOCUMENTS

AU 2015253128 B2 3/2018
 CA 2705814 C 2/2018
 CA 2947524 C 4/2018
 CN 2702363 Y 5/2005
 CN 107251671 A 10/2017
 EP 1408476 A1 4/2004
 EP 1647766 A2 4/2006
 EP 1762892 A1 3/2007
 EP 1951020 A1 7/2008
 EP 2225603 A2 9/2010
 EP 2370987 A2 10/2011
 EP 2603831 A2 6/2013
 EP 2801888 A2 11/2014
 EP 2909829 A1 8/2015
 EP 3020260 A2 5/2016
 EP 3117693 A2 1/2017
 EP 3259968 A1 12/2017
 GB 2402205 A 12/2004
 JP 402062015 A 3/1990
 JP 402307080 A 12/1990
 JP 3153212 A 7/1991
 JP H06-2337 U 1/1994
 JP 6082745 A 3/1994
 JP 8115788 A 5/1996
 JP 8194437 A 7/1996
 JP H08-305301 A 11/1996
 JP 8339034 A 12/1996
 JP H09246766 A 9/1997
 JP 11160727 A 6/1999
 JP H11296094 A 10/1999
 JP 2000-10501 A 1/2000
 JP 2001209126 A 8/2001
 JP 2002158475 A 5/2002
 JP 2004053749 A 2/2004
 JP 2004-199675 A 7/2004
 JP 2005017556 A 1/2005
 JP 2000131682 A 5/2005
 JP 2005134849 A 5/2005
 JP 2005265922 A 9/2005
 JP 2006513577 A 4/2006
 JP 2007322718 A 5/2006
 JP 2006148047 A 6/2006
 JP 2006163217 A 6/2006
 JP 2007003638 A 1/2007
 JP 2007-293105 A 11/2007
 JP 09307257 A 11/2007
 JP 2008010361 A 1/2008
 JP 2008292743 A 12/2008
 JP 2010024624 A 2/2010
 JP 2010-102227 A 5/2010
 JP 2010-282109 A 12/2010
 JP 2011-503663 A 1/2011
 JP 2011-75819 A 4/2011
 JP 2012-133254 A 7/2012
 JP 2013-537721 A 10/2013
 JP 2014-225595 A 12/2014
 JP 2017518526 A 7/2017
 JP 2018-511838 A 4/2018
 JP 6305564 B2 4/2018
 KR 200366674 Y1 11/2004
 KR 20050033986 A 4/2005
 KR 200401354 Y1 11/2005
 KR 20060016469 A 2/2006
 KR 100666961 B1 1/2007
 KR 1020070070675 A 4/2007
 KR 1020070048294 8/2007
 KR 101764381 B1 7/2017
 KR 10-1847151 B1 4/2018
 KR 10-1853885 B1 4/2018
 KR 10-1868077 B1 6/2018
 KR 10-1885884 B1 7/2018

(56)

References Cited

FOREIGN PATENT DOCUMENTS

RU	2513043	C2	4/2014
WO	WO2005079129	A1	8/2005
WO	WO2007116116	A1	10/2007
WO	WO2008050660	A2	5/2008
WO	WO2009065125	A2	5/2009
WO	WO2009065125	A3	5/2009
WO	WO2009135308	A1	11/2009
WO	WO2010007821	A1	2/2010
WO	WO2010080624	A2	7/2010
WO	WO2011069084	A3	6/2011
WO	WO2011072217	A3	6/2011
WO	WO2011140179	A1	11/2011
WO	WO2011150078	A2	12/2011
WO	WO2012021573	A2	2/2012
WO	WO2012024426	A3	2/2012
WO	2013182733	A1	12/2013
WO	WO2014062815	A1	4/2014
WO	WO2014149773	A1	9/2014
WO	WO2014150036	A1	9/2014
WO	WO2015168375	A1	11/2015
WO	WO2016102982	A1	6/2016
WO	WO2016127613	A1	8/2016
WO	WO2016133852	A1	8/2016
WO	WO2017152166	A1	9/2017

OTHER PUBLICATIONS

Itsenclosures, Standard Product Data Sheet, 2011, 18 pages.
 Sunbritetv, All Weather Outdoor LCD Television Model 4610HD, 2008, 1 page.
 Sunbritetv, Introduces Two New All-Weather Outdoor Televisions InfoComm 2008, 7 pages.
 Itsenclosures, Viewstation, 2017, 16 pages.
 Novitsky, Driving LEDs versus CCFLs for LCD backlighting, Nov. 12, 2007, 6 pages.
 Federman, Cooling Flat Panel Displays, 2011, 4 pages.
 Zeff, T.M., EMC analysis of an 18" LCD monitor, 2000, 1 page.
 Vertigo Digital Displays, Innovation on Display FlexVu Totem Brochure, 2014, 6 pages.

Vertigo Digital Displays, FlexVu Totem Shelter, 2017, 2 pages.
 Vertigo Digital Displays, All Products Catalogue, 2017, 14 pages.
 Adnation, Turn Key Advertising Technology Solutions, May 23, 2017, 4 pages.
 CIVIQ Smartscares, FlexVue Ferro 55P/55L, Mar. 16, 2017, 4 pages.
 Wankhede, Evaluation of Cooling Solutions for Outdoor Electronics, Sep. 17-19, 2007, 6 pages.
 Bureau of Ships Navy Department, Guide Manual of Cooling methods for Electronic Equipment, Mar. 31, 1955, 212 pages.
 CIVIQ, Invalidity Claim Charts, Appendix A-Appendix D, Jan. 24, 2018, 51 pages.
 CIVIQ, Invalidity Contentions, Jan. 24, 2018, 51 page
 Scott, Cooling of Electronic Equipment, Apr. 4, 1947, 119 pages.
 Sergeant, Thermal Management Handbook for Electronic Assemblies, Aug. 14, 1998, 190 pages.
 Steinberg, Cooling Techniques for Electronic Equipment First Edition, 1980, 255 pages.
 Steinberg, Cooling Techniques for Electronic Equipment Second Edition, 1991, 299 pages.
 Yeh, Thermal Management of Microelectronic Equipment, Oct. 15, 2002, 148 pages.
 CIVIQ, Invalidity Claim Chart, Appendix I, Mar. 22, 2018, 4 pages.
 CIVIQ, Invalidity Claim Charts, Appendix F to H, Mar. 22, 2018, 18 pages.
 Yung, Using Metal Core Printed Circuit Board as a Solution for Thermal Management article, 2007, 5 pages.
 Mentley, David E., State of Flat-Panel Display Technology and Future Trends, Proceedings of the IEEE, Apr. 2002, vol. 90, No. 4, pp. 453-459.
 Rohsenow, Warren M., Handbook of Heat Transfer, Third Edition, 1998, select chapters, 112 pages, McGraw-Hill.
 The American Heritage College Dictionary, Third Edition, 1993, excerpt, 3 pages, Houghton Mifflin Company.
CIVIQ Smartscares LLC. v Manufacturing Resources International, Inc., Petition for Inter Partes Review of U.S. Pat. No. 8,854,572 including Declaration of Greg Blonder in Support of Petition, Curriculum Vitae of Greg Blonder and Prosecution History of U.S. Pat. No. 8,854,572, Petition filed Mar. 14, 2018, 427 pages.
CIVIQ Smartscares LLC. v Manufacturing Resources International, Inc., Defendant's Amended Answer and Counterclaims to Plaintiffs First Amended Complaint, Filed Apr. 24, 2018, 240 pages.

* cited by examiner

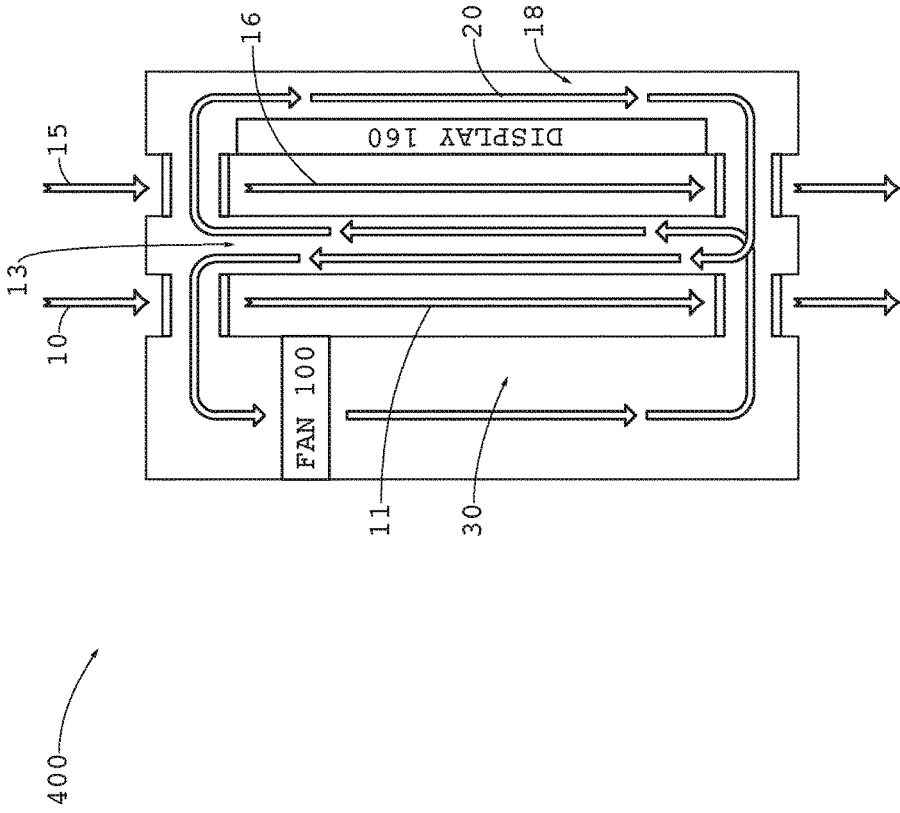

Fig. 1

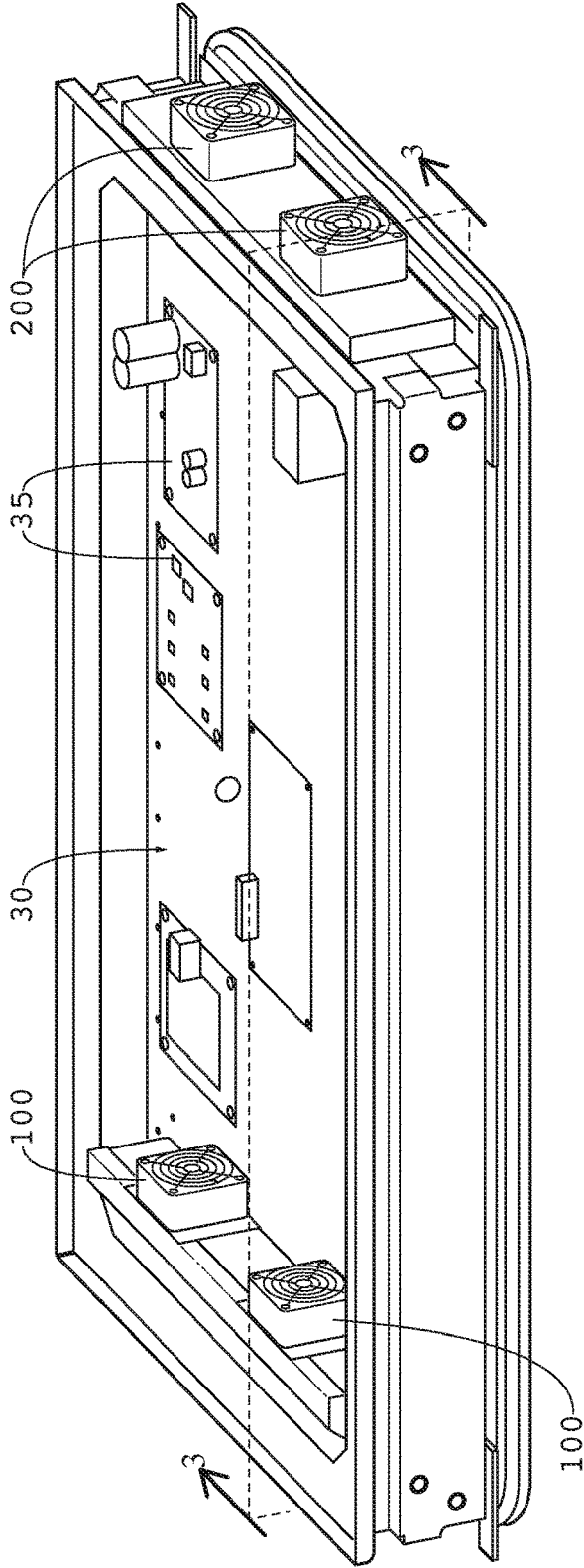

Fig. 2

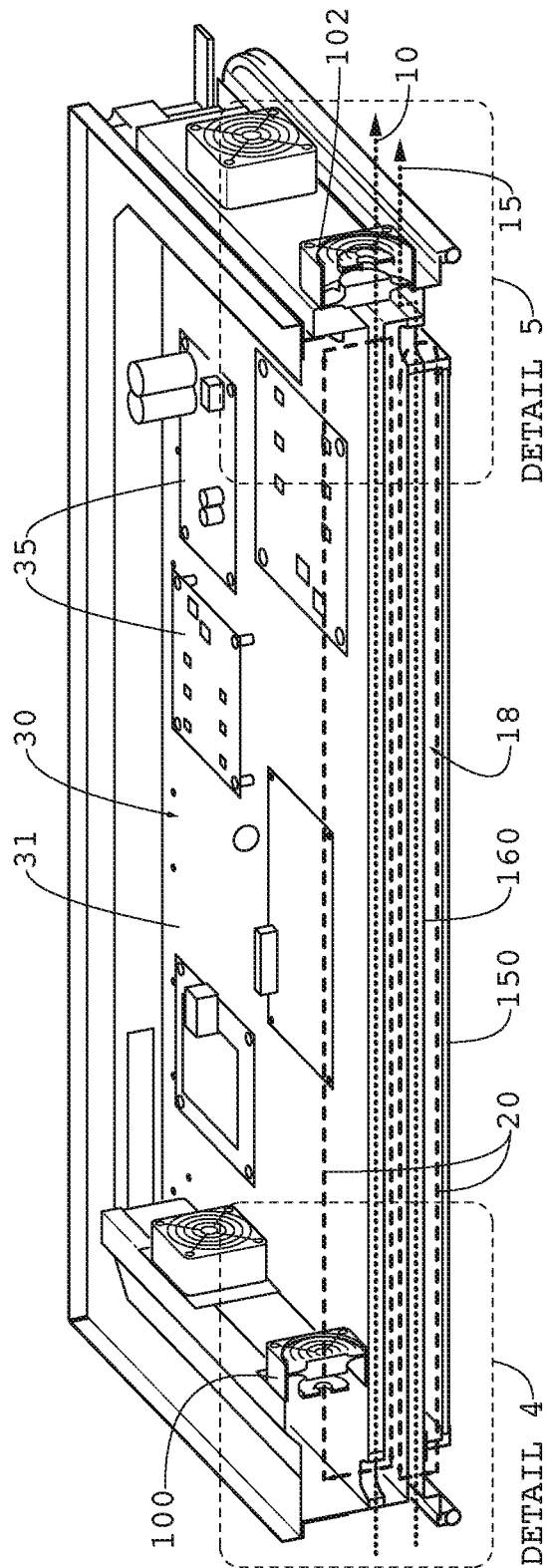

Fig. 3

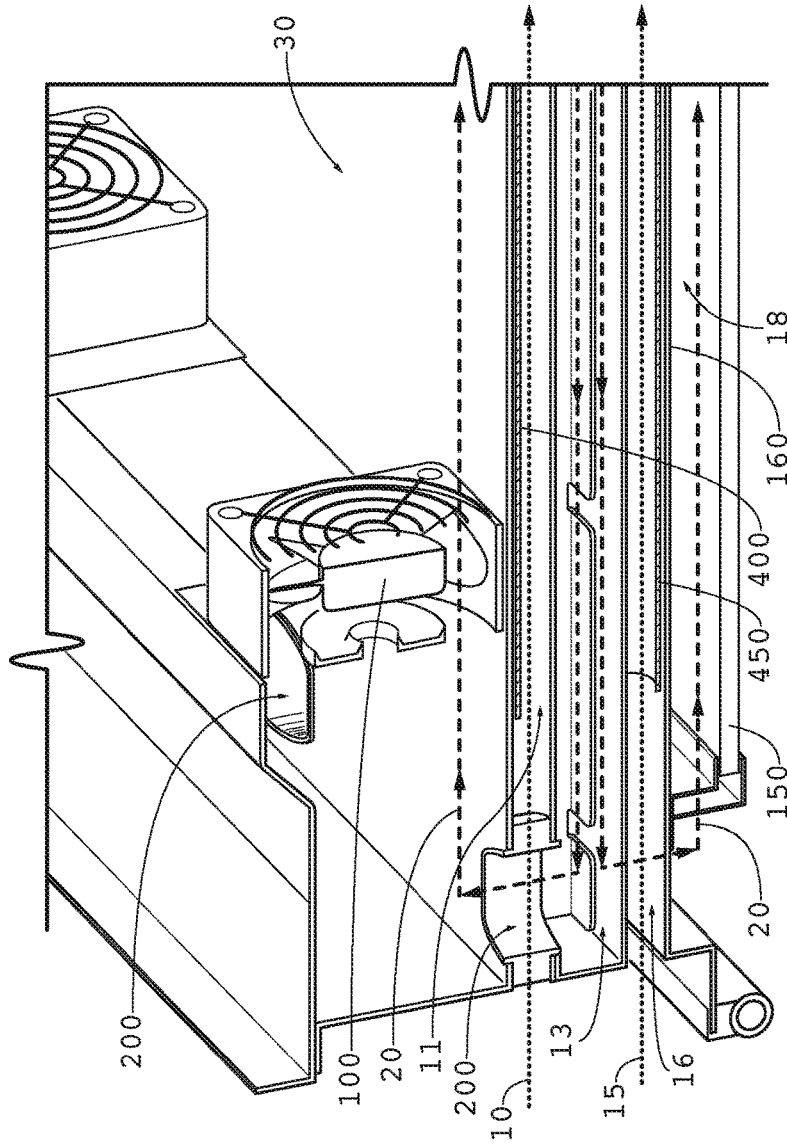

Fig. 4

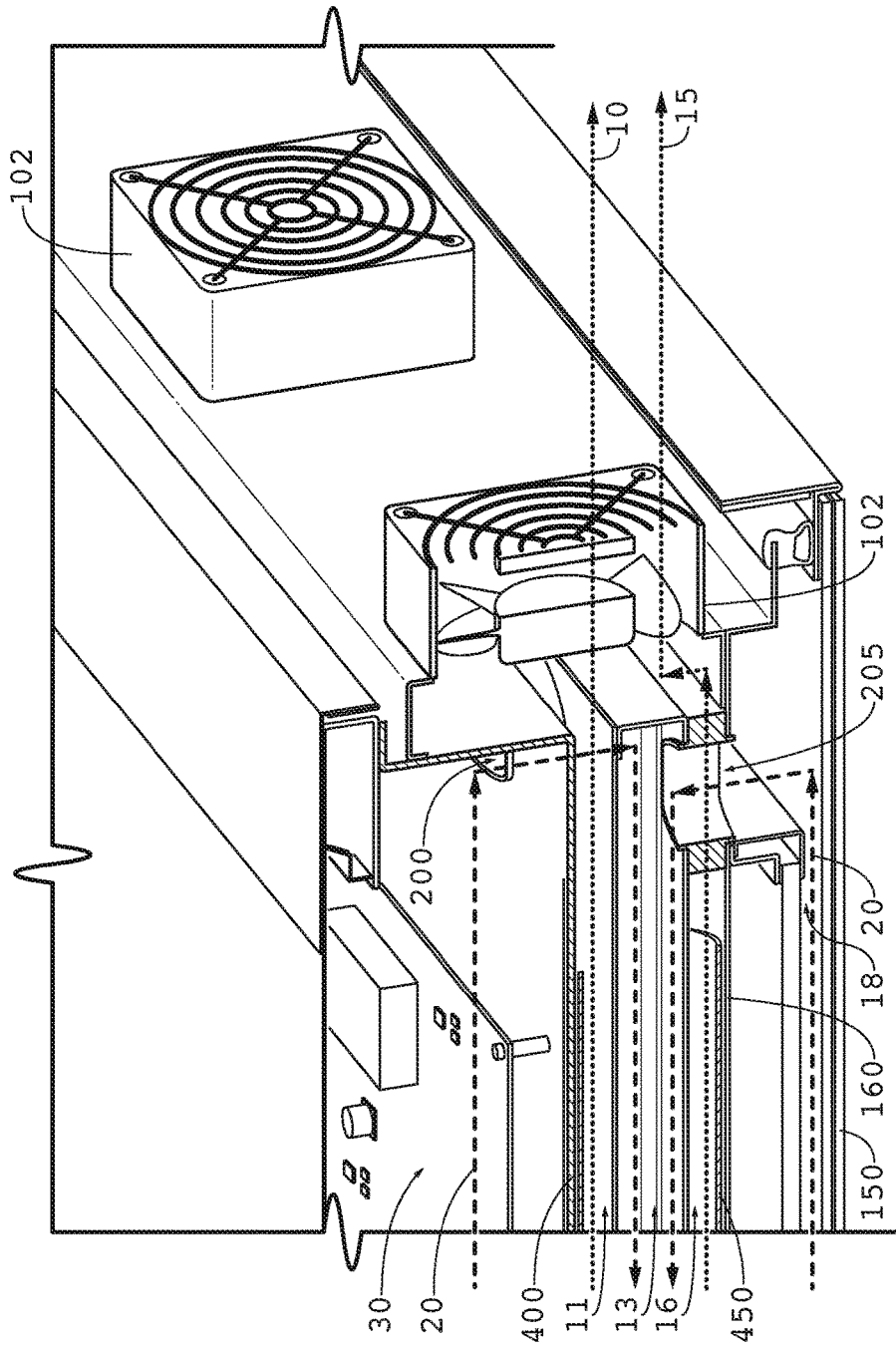

Fig. 5

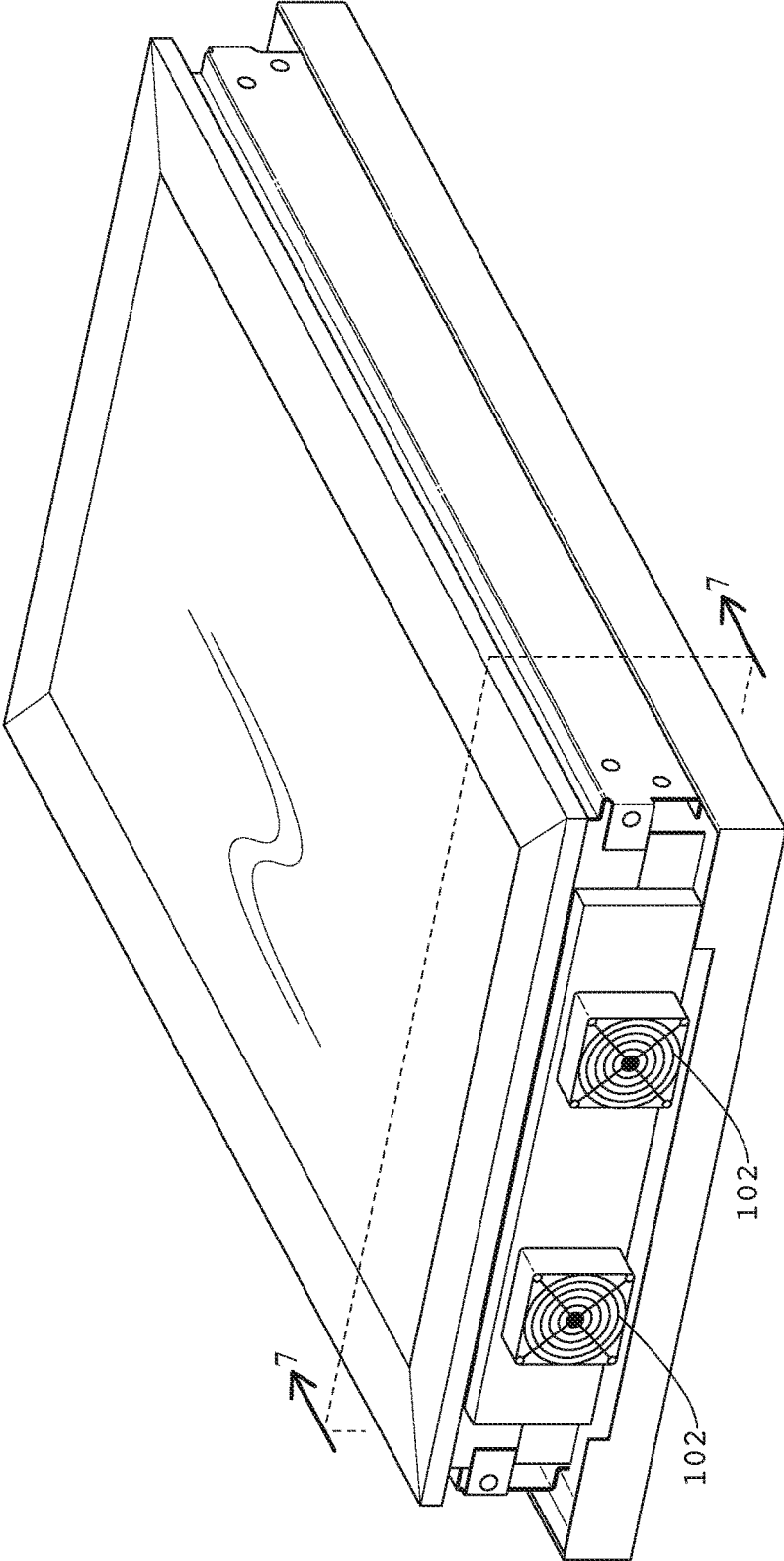

Fig. 6

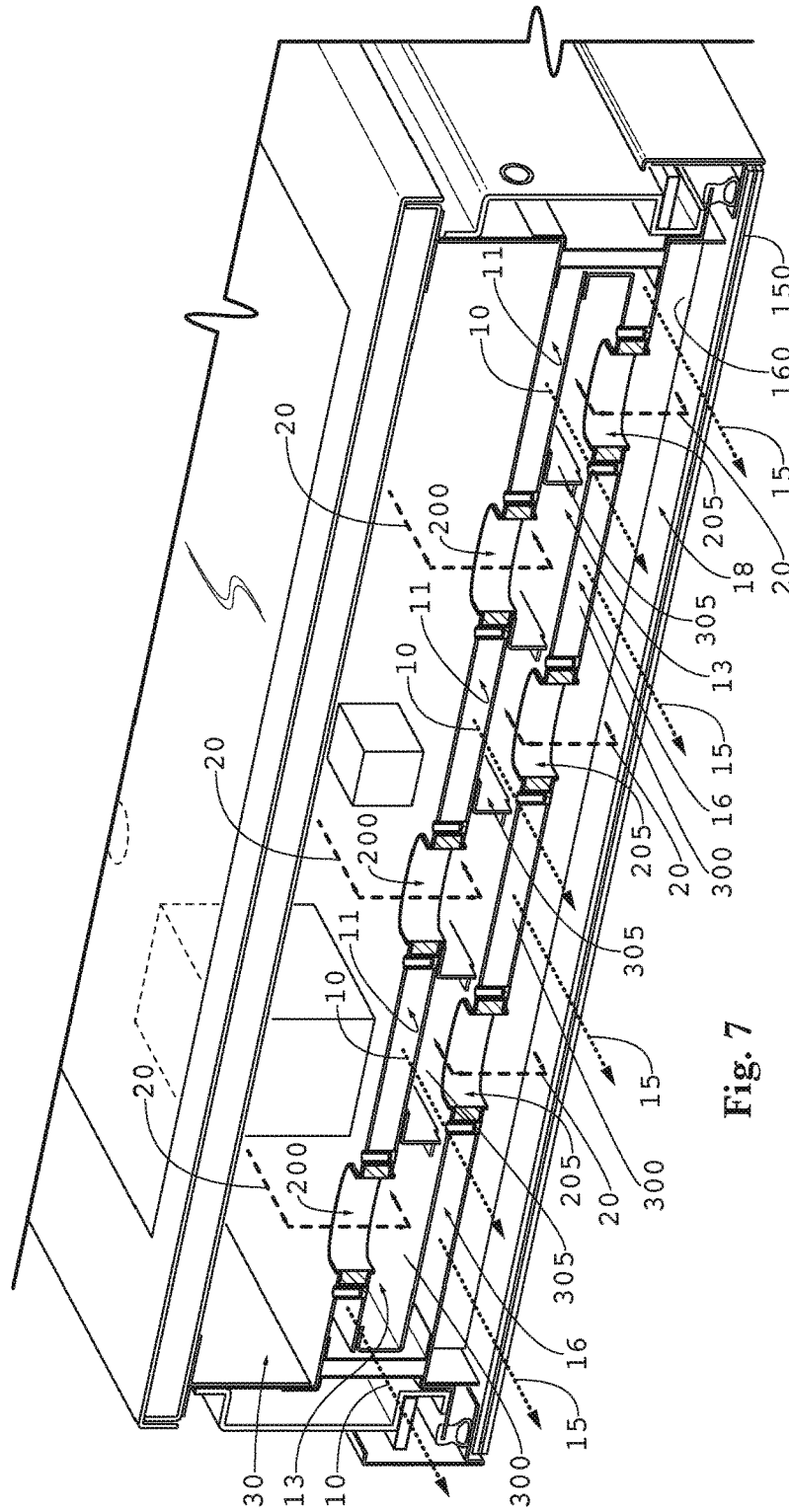

Fig. 7

1

COOLING SYSTEM FOR ELECTRONIC DISPLAY

CROSS-REFERENCE TO RELATED APPLICATIONS

This application is a continuation of U.S. patent application Ser. No. 15/289,563 filed on Oct. 10, 2016, which is a continuation of U.S. patent application Ser. No. 14/326,059 filed on Jul. 8, 2014 now U.S. Pat. No. 9,470,924, which claims priority to U.S. Provisional Application No. 61/843,706 filed on Jul. 8, 2013, the disclosures of each of these applications are hereby incorporated by reference in their entireties.

TECHNICAL FIELD

Embodiments generally relate to cooling systems for electronic displays.

BACKGROUND OF THE ART

Electronic displays are sometimes used in outdoor environments or other areas where the surrounding temperatures may be high or there may be other sources of heat such as solar loading causing the temperatures within the display to rise. However, some portions of the display can be difficult to cool as simply ingesting ambient air into some portions of the display can introduce dust and contaminants into sensitive portions of the display, which can lead to premature failures.

SUMMARY OF THE EXEMPLARY EMBODIMENTS

Exemplary embodiments provide a figure eight closed loop circulating gas path which defines a center channel for the closed loop of circulating gas. A pair of open loop ambient air channels may be placed on opposite sides of the center channel, in order to remove heat from at least the center channel and the closed loop circulating gas. One or more open loop ambient air pathways may pass through the figure eight but do not allow the circulating gas and the ambient air to mix. In some embodiments, the open loop ambient air pathway travels along a rear surface of the electronic display. In some embodiments, the circulating gas pathways contain a front channel placed in front of the electronic display, a rear channel placed behind the electronic display, and a center channel placed between the front and rear channels. Pass-through apertures may be placed within the path of the circulating gas and/or the ambient air to allow the paths of the two gaseous matters to cross without allowing them to mix with one another.

The foregoing and other features and advantages of the present invention will be apparent from the following more detailed description of the particular embodiments, as illustrated in the accompanying drawings.

BRIEF DESCRIPTION OF THE DRAWINGS

A better understanding of an exemplary embodiment will be obtained from a reading of the following detailed description and the accompanying drawings wherein identical reference characters refer to identical parts and in which:

FIG. 1 is a simplified illustration of an exemplary embodiment of the figure eight closed loop cooling system.

2

FIG. 2 is a side rear perspective view showing the overall assembly of the display with the rear cover removed and indicating the section line 3-3.

FIG. 3 is a perspective section view taken from the section line 3-3 and indicating the locations for Detail 4 and Detail 5.

FIG. 4 is a detailed perspective section view of Detail 4.

FIG. 5 is a detailed perspective section view of Detail 5.

FIG. 6 is a bottom rear perspective view showing the overall assembly of the display and indicating the section line 7-7.

FIG. 7 is a perspective section view taken from the section line 7-7.

DETAILED DESCRIPTION

The invention is described more fully hereinafter with reference to the accompanying drawings, in which exemplary embodiments of the invention are shown. This invention may, however, be embodied in many different forms and should not be construed as limited to the exemplary embodiments set forth herein. Rather, these embodiments are provided so that this disclosure will be thorough and complete, and will fully convey the scope of the invention to those skilled in the art. In the drawings, the size and relative sizes of layers and regions may be exaggerated for clarity.

The terminology used herein is for the purpose of describing particular embodiments only and is not intended to be limiting of the invention. As used herein, the singular forms “a”, “an” and “the” are intended to include the plural forms as well, unless the context clearly indicates otherwise. It will be further understood that the terms “comprises” and/or “comprising,” when used in this specification, specify the presence of stated features, integers, steps, operations, elements, and/or components, but do not preclude the presence or addition of one or more other features, integers, steps, operations, elements, components, and/or groups thereof.

Embodiments of the invention are described herein with reference to illustrations that are schematic illustrations of idealized embodiments (and intermediate structures) of the invention. As such, variations from the shapes of the illustrations as a result, for example, of manufacturing techniques and/or tolerances, are to be expected. Thus, embodiments of the invention should not be construed as limited to the particular shapes of regions illustrated herein but are to include deviations in shapes that result, for example, from manufacturing.

Unless otherwise defined, all terms (including technical and scientific terms) used herein have the same meaning as commonly understood by one of ordinary skill in the art to which this invention belongs. It will be further understood that terms, such as those defined in commonly used dictionaries, should be interpreted as having a meaning that is consistent with their meaning in the context of the relevant art and will not be interpreted in an idealized or overly formal sense unless expressly so defined herein.

FIG. 1 is a simplified illustration of an exemplary embodiment of the figure eight closed loop cooling system 400. This exemplary embodiment contains a plurality of channels in the assembly. The front channel 18 is placed in front of the display 160 and preferably allows closed loop circulating gas 20 to remove heat from the front of the display 160. The front open loop channel 16 is positioned behind the display 160 and preferably allows open loop air 15 to pass behind the display 160, removing heat at least from the rear portion of the display 160 and the center channel 13. The center channel 13 is preferably positioned between the front open

loop channel 16 and the rear open loop channel 11 and allows closed loop circulating gas 20 to cross paths with itself (creating the figure eight) and to cross paths with the open loop air 10 and 15 without allowing the closed loop circulating gas and open loop air to mix.

The rear open loop channel 11 is preferably positioned immediately adjacent to the center channel 13, and allows open loop air 10 to flow through, thereby removing heat from the center channel 13 (and/or the closed loop circulating gas 13 contained within) and the rear channel 30. The rear channel 30 is positioned near the rear of the display and may contain various electronic components 35 for operating the overall display assembly, fans, or the display 160 itself.

In an exemplary embodiment, the front channel 18, center channel 13, and rear channel 30 are in sealed gaseous communication with each other. In other words, these channels do not permit closed loop circulating gas 20 to substantially escape or to allow ambient air or open loop air to enter these channels. Also in an exemplary embodiment, open loop air 10 and 15 is simply ambient air surrounding the display assembly. However, in some embodiments the open loop air 10 and 15 may be treated in some way (e.g. filtered, air conditioned, or pre-cooled in some way) prior to being ingested into the display assembly. In this particular embodiment, the closed loop fan 100 is positioned within the rear channel 30, although this is not required. All that is required is that the closed loop fan 100 is positioned to force the closed loop circulating gas 20 through the front channel 18, center channel 13, and rear channel 30. The closed loop circulating gas 20 can be any gaseous matter that preferably does not contain large amounts of particulate. However, it does not have to be pure gas of any type; simple clean air works fine with the exemplary embodiments.

FIG. 2 is a side rear perspective view showing the overall assembly of the display with the rear cover removed and indicating the section line 3-3. In this particular embodiment, the display assembly is designed for a portrait orientation with the closed loop fans 100 positioned at the top of the assembly and the open loop fans 200 positioned at the bottom of the assembly. This is of course not required however, as the embodiments herein can be flipped or oriented for a landscape orientation if desired. Further, the open loop fans 200 do not have to be placed at the bottom of the assembly, but could be positioned anywhere so that the open loop air travels in the paths specified in these exemplary embodiments. It of course goes without saying that additional fans could also be used to increase flow rates and/or pressure.

FIG. 3 is a perspective section view taken from the section line 3-3 and indicating the locations for Detail 4 and Detail 5. Here, the front channel 18 is defined between the front transparent plate 150 and the electronic display 160. In an exemplary embodiment the electronic display 160 may be an LED backlit liquid crystal display (LCD), but this is not required. Alternative embodiments may utilize any type of flat panel electronic display, including but not limited to plasma, OLED, electroluminescent polymers, or similar. In some embodiments, the various electrical components 35 (power supplies, printed circuit boards, microprocessors, electronic storage, etc.) may be attached and in thermal communication with a plate 31 which may form the rear portion of channel 11 for open loop air 10. In this way, heat that is generated by the electrical components 35 may be transferred to the plate 31, where it can be removed by open loop air 10.

FIG. 4 is a detailed perspective section view of Detail 4. Closed loop circulating gas 20 is permitted to pass through

the rear open loop channel 11 without mixing with the open loop air 10 by use of pass-through apertures 200, which provide sealed gaseous communication between the rear channel 30 and the center channel 13, without permitting open loop air 10 to enter the channels 30 and 13. In an exemplary embodiment, rear open loop channel 11 may also contain cooling fins 400 for distributing heat from the adjacent channels (30 and 13) and/or electronic components 35 in order to be efficiently removed by the open loop air 10. Similarly, front open loop channel 16 may also contain cooling fins 450 for distributing heat from the adjacent channels (30 and 18) and/or the rear surface of the display 160 in order to be efficiently removed by the open loop air 15. In an exemplary embodiment, the display 160 contains a direct lit LED backlight where the cooling fins 450 are placed in thermal communication with the LED backlight. The cooling fins 450 and 400 may be comprised of any thermally conductive material, but would preferably be comprised of metal and in an exemplary embodiment would be a thin sheet (or multiple thin sheets) of metal.

FIG. 5 is a detailed perspective section view of Detail 5. Closed loop circulating gas 20 is permitted to pass through the front open loop channel 16 without mixing with the open loop air 15 by use of pass-through apertures 205, which provide sealed gaseous communication between the front channel 18 and the center channel 13, without permitting open loop air 15 to enter the channels 18 and 13.

FIG. 6 is a bottom rear perspective view showing the overall assembly of the display and indicating the section line 7-7.

FIG. 7 is a perspective section view taken from the section line 7-7. The center channel 13 is preferably divided into a plurality of subchannels 300 and 305. On this end of the overall assembly, subchannels 300 are in gaseous communication with the pass-through apertures 200 (which connects the subchannel 300 with the rear channel 30) while subchannels 305 are in gaseous communication with the pass-through apertures 205 (which connects the subchannel 305 with the front channel 18). However, on the opposite end of the assembly (see FIG. 3) subchannels 300 are in gaseous communication with the pass-through apertures 205 (which connects the subchannel 300 with the front channel 18) while subchannels 305 are in gaseous communication with the pass-through apertures 200 (which connects the subchannel 305 with the rear channel 30). In this way, the closed loop of circulating gas 20 travels through the front channel 18, through a pass-through aperture to travel along subchannel 305, through another pass-through aperture to travel along the rear channel 30, through another pass-through aperture to travel along the subchannel 300, and finally through another pass-through aperture to return to the front channel 18. In this way, the closed loop of circulating gas 20 performs the 'figure eight' through the assembly, as it weaves its way across the front channel 18, through the center channel 13, across the rear channel 30, again through the center channel 13, and returning to the front channel 18.

It should be noted that subchannels 300 and 305 may not be required in some embodiments as the center channel 13 could be completely open. It should also be noted that other embodiments may use the subchannels 300 and 305 but would not allow a single subchannel to communicate gaseously with both the front channel 18 and the rear channel 30. In other words, when viewing the end of the assembly as shown in FIG. 7, the opposing end of the assembly would be substantially similar. Thus, subchannels 300 would only communicate with pass-through apertures 200 and the rear channel 30, while the subchannels 305 would only commu-

nicate with pass-through apertures **205** and front channel **18**. Thus, in this embodiment there would be two separate closed loops.

Although there is preferably gaseous communication throughout the figure eight, subchannel **300** directs the flow of closed loop circulating gas **20** through rear channel **30** and center channel **13** while subchannel **305** directs the flow of closed loop circulating gas **20** through the center channel **13** and front channel **18**. In this preferred embodiment, the subchannels **300** and **305** allow separate flow paths for closed loop circulating gas **20** within the center channel **13**, without requiring additional fans. These separate flow paths which cross through the center and loop around the display in a single continuous flow, define the figure eight path for the closed loop circulating gas **20** (seen also in FIG. **1**). Further, in this preferred embodiment, the flow direction of closed loop circulating gas **20** through the center channel **13** is opposite the flow direction of open loop air **15** and **10**, creating a counter-flow heat exchanger between the center channel **13** and the front/rear open loop channels **11** and **16**. However, this is not required, as a parallel flow or a cross flow design would work as well.

In an exemplary embodiment, the rear channel **30** would share a plate with the rear open loop channel **11**, such that one side of the plate would be within the rear channel **30** while the opposing side of the plate would be within the rear open loop channel **11**. This arrangement is illustrated in FIG. **3** with the rear plate **31**. Similarly, it may be preferable for the center channel **13** and the rear open loop **11** to share a plate, such that one side of the plate is within the center channel **13** while the other side of the plate is within the rear open loop **11**. Similarly, it may be preferable for the center channel **13** and the front open loop **16** to share a plate. Finally, it may also be preferable for the rear surface of the display **160** to form the front wall of the front open loop **16**, such that open loop ambient air **15** can remove heat from the electronic display **160**. In some embodiments the rear surface of the display **160** would be the rear surface of a metallic PCB holding a plurality of LEDs for the backlight.

Having shown and described a preferred embodiment of the invention, those skilled in the art will realize that many variations and modifications may be made to affect the described invention and still be within the scope of the claimed invention. Additionally, many of the elements indicated above may be altered or replaced by different elements which will provide the same result and fall within the spirit of the claimed invention. It is the intention, therefore, to limit the invention only as indicated by the scope of the claims.

We claim:

1. A cooling assembly for an electronic display comprising:

a front channel that passes in front of the viewable area of the electronic display;

a center channel located behind the electronic display;

a rear channel located behind the center channel;

a first plurality of subchannels located within the center channel and connecting only to the front channel; and

a second plurality of subchannels located within the center channel and connecting only to the rear channel;

wherein the front channel, the center channel, and the rear channel form a continuous closed loop pathway for circulating gas.

2. The cooling assembly of claim **1** wherein:

the first plurality of subchannels are connected to the front channel by way of a first plurality of pass through devices; and

the second plurality of subchannels are connected to the rear channel by way of a second plurality of pass through devices.

3. The cooling assembly of claim **1** wherein:

the first and second plurality of subchannels are configured to permit circulating gas to flow therethrough without substantially mixing.

4. The cooling assembly of claim **1** wherein:

the front channel is further defined as extending between a front surface of the electronic display and a transparent plate.

5. The cooling assembly of claim **1** wherein:

the rear channel comprises electronic components which are mounted to a plate.

6. The cooling assembly of claim **2** further comprising: an open loop pathway that passes between the front channel and the rear channel.

7. The cooling assembly of claim **6** further comprising: a second open loop pathway that passes between the front channel and the rear channel.

8. The cooling assembly of claim **6** wherein:

the open loop pathway travels along a rear surface of the electronic display.

9. The cooling assembly of claim **6** wherein:

each of the first and second plurality of pass through devices comprises an aperture, wherein the pass through devices are arranged such that circulating gas travels through the aperture while ambient air passes around the aperture.

10. A cooling assembly for an electronic display comprising:

a first channel placed in front of the electronic display;

a third channel placed behind the electronic display; and

a second channel placed between the first channel and the third channel, wherein the second channel comprises a first plurality of subchannels and a second plurality of subchannels;

wherein the first plurality of subchannels are connected only to the first channel;

wherein the second plurality of subchannels are connected only to the third channel,

wherein the second channel is configured to permit circulating gas to flow simultaneously through the first and second plurality of subchannels without substantially mixing;

wherein said first, second, and third channels form a continuous closed loop pathway for circulating gas.

11. The cooling assembly of claim **10** further comprising:

a first plurality of pass through devices connecting the first plurality of subchannels to the first channel; and

a second plurality of pass through devices connecting the second plurality of subchannels to the third channel.

12. The cooling assembly of claim **10** wherein:

the first, second, and third channels are interconnected in a way which forms a substantially figure eight shape.

13. The cooling assembly of claim **11** further comprising: a first open loop pathway for ambient air positioned between the electronic display and the second channel; and

a second open loop pathway for ambient air positioned between the second channel and the third channel.

14. The cooling assembly of claim **13** further comprising: a closed loop fan positioned to force ambient air through at least one of the first, second, or third channels.

15. The cooling assembly of claim **14** further comprising: an open loop fan positioned to force ambient air through at least one of the first or second open loop pathways.

- 16.** A cooling assembly for an electronic display comprising:
 - a continuous closed loop pathway for circulating gas comprising:
 - a front channel defined by the space between a front surface of the electronic display and a transparent plate;
 - a plate positioned behind the electronic display;
 - a rear channel defined by the space between the plate and the rear surface of the cooling assembly; and
 - a center channel located between the plate and the rear surface of the electronic display and comprising a first number of independent subchannels and a second number of independent subchannels;
 - wherein the first number of independent subchannels connect only to the front channel;
 - wherein the second number of independent subchannels connect only to the rear channel.
- 17.** The cooling assembly of claim **16** wherein: the center channel is configured to allow the circulating gas to travel through any of said independent subchan-

- nels without substantially mixing with circulating gas traveling through any of the other independent subchannels.
- 18.** The cooling assembly of claim **17** further comprising:
 - a first plurality of pass through devices connecting the first number of independent subchannels to the front channel; and
 - a second plurality of pass through devices connecting the second number of independent subchannels to the rear channel.
- 19.** The cooling assembly of claim **18** further comprising: an open loop for ambient air configured to pass between the front and the rear channels without mixing the ambient air and the circulating gas.
- 20.** The cooling assembly of claim **19** further comprising:
 - at least one closed loop fan positioned to force the flow of the circulating gas through the closed loop; and
 - at least one open loop fan positioned to force the flow of the ambient air through the open loop.

* * * * *