

[54] BICYCLE FRAME

[76] Inventor: William M. Savage, 1472 Chariot Ct.,
Bonsall, Calif. 92003

[**] Term: 14 Years

[21] Appl. No.: 434,830

[22] Filed: Nov. 13, 1989

[52] U.S. Cl. D12/111

[58] Field of Search D12/111; 280/281.1,
280/288.1, 288.2, 288.3, 284

American Bicyclist & Motorcyclist, Dec. 1988, p. 91,
Mag Magic Bicycle frame from Kirk Bicycles USA.
American Bicyclist & Motorcyclist, Jan. 1986, p. 16,
Cinell's Sprung Laser Bicycle.
American Bicyclist & Motorcyclist, Dec. 1986, p. 98,
Ko Chin frame No. KC-5.

Primary Examiner—James M. Gandy
Assistant Examiner—Melody N. Brown
Attorney, Agent, or Firm—Francis X. LoJacono

[57] CLAIM

The ornamental design for a bicycle frame, as shown.

DESCRIPTION

FIG. 1 is a perspective view of a bicycle frame, showing
my new design;

FIG. 2 is a top-plan view thereof;

FIG. 3 is a right side-elevational view thereof;

FIG. 4 is a bottom plan view thereof;

FIG. 5 is a front elevational view thereof;

FIG. 6 is a rear elevational view thereof; and

FIG. 7 is a left side-elevational view thereof.

[56] References Cited

U.S. PATENT DOCUMENTS

D. 204,925 5/1966 Silbereis et al. D12/111
4,746,136 5/1988 Kirk 280/281.1

OTHER PUBLICATIONS

American Bicyclist & Motorcyclist, Mar. 1989, p. 56,
Mens Alloy Fire Red 20" Bicycle.

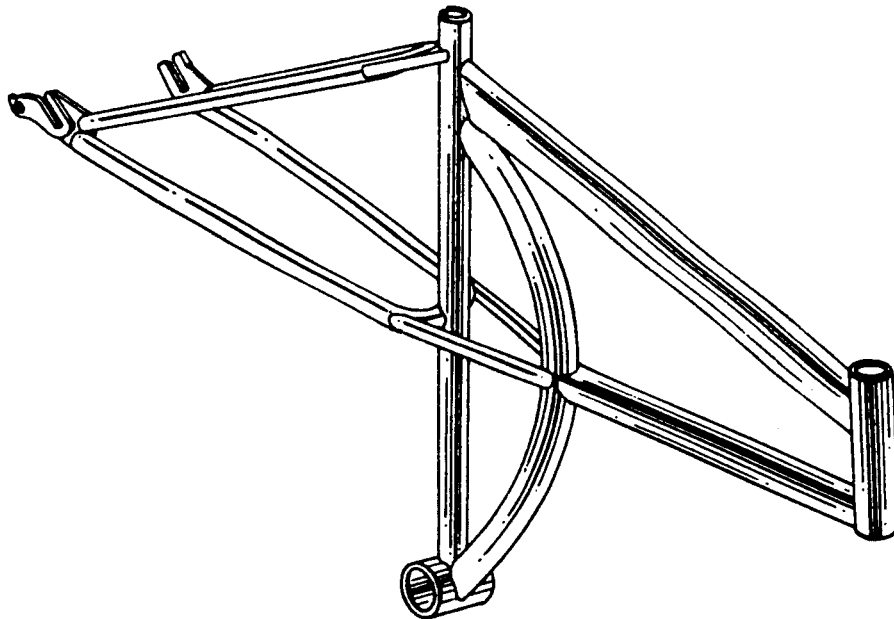

FIG. 1

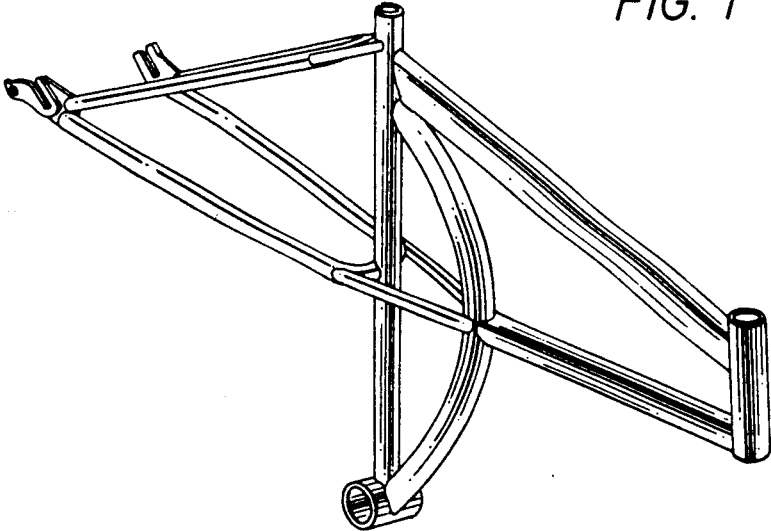

FIG. 2

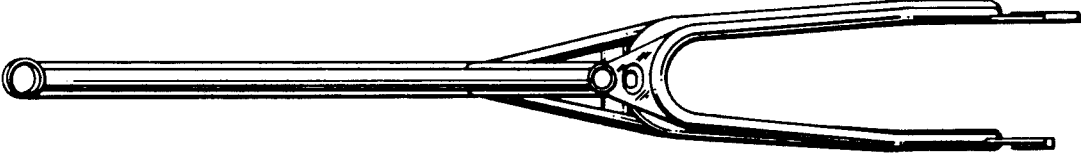
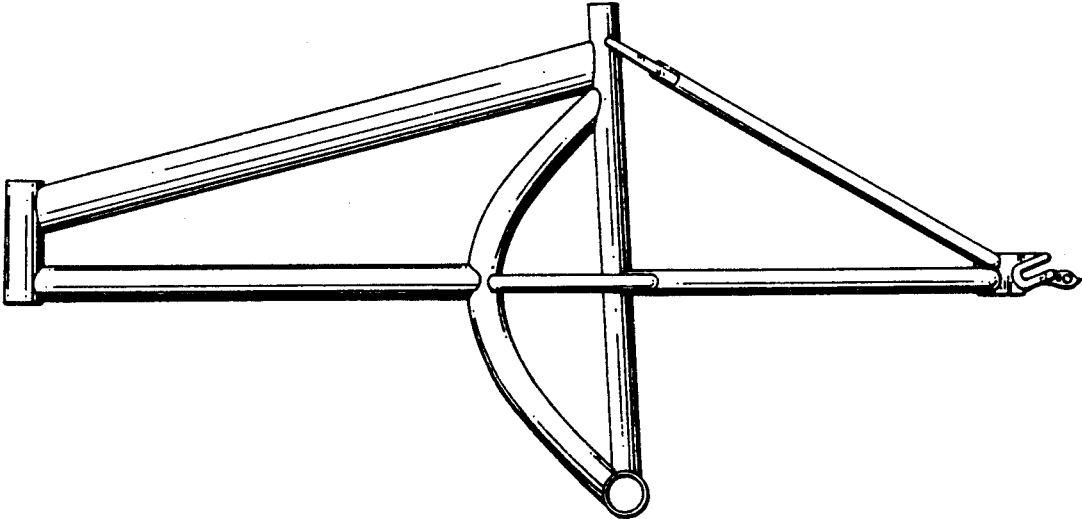

FIG. 3



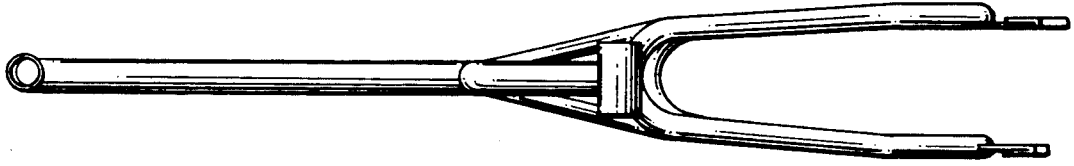

FIG. 4

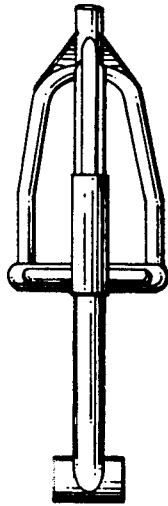

FIG. 5

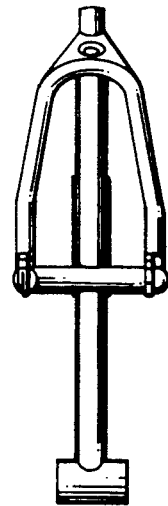

FIG. 6

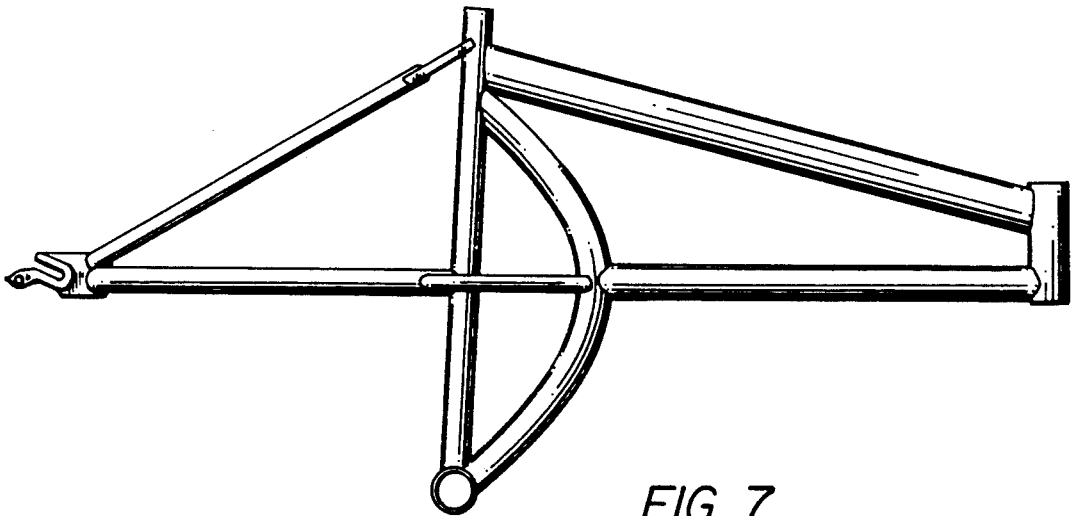

FIG. 7