



US00D370436S

# United States Patent [19]

Warren et al.

[11] Patent Number: **Des. 370,436**

[45] Date of Patent: **\*\*Jun. 4, 1996**

[54] **BICYCLE FRAME**

5,354,085 10/1994 Gally ..... 280/284

[75] Inventors: **Scott Warren**, Little Rock; **Dean Fagaly**, Maumelle, both of Ark.

*Primary Examiner*—Melody N. Brown  
*Attorney, Agent, or Firm*—Mark Rogers; Ray F. Cox, Jr.

[73] Assignee: **King Cycles, Inc.**, Little Rock, Ark.

### [57] CLAIM

[\*\*] Term: **14 Years**

The ornamental design for a bicycle frame, as shown and described.

[21] Appl. No.: **42,201**

### DESCRIPTION

[22] Filed: **Aug. 3, 1995**

[52] U.S. Cl. .... **D12/111**

[58] Field of Search ..... D12/111; 280/281.1, 280/288.1, 288.2, 288.3, 284

FIG. 1 is a side elevational view of the bicycle frame showing our new design, taken from the right side thereof; FIG. 2 is a front elevational view thereof;

FIG. 3 is a side elevational view taken from the left side thereof;

FIG. 4 is a rear elevational view thereof;

FIG. 5 is a top plan view thereof; and,

FIG. 6 is a bottom plan view thereof.

### [56] References Cited

#### U.S. PATENT DOCUMENTS

D. 321,156	10/1991	Browning	.....	D12/111
D. 331,376	12/1992	Sewell	.....	D12/111
D. 335,640	5/1993	Gasiorowski	.....	D12/111

**1 Claim, 3 Drawing Sheets**

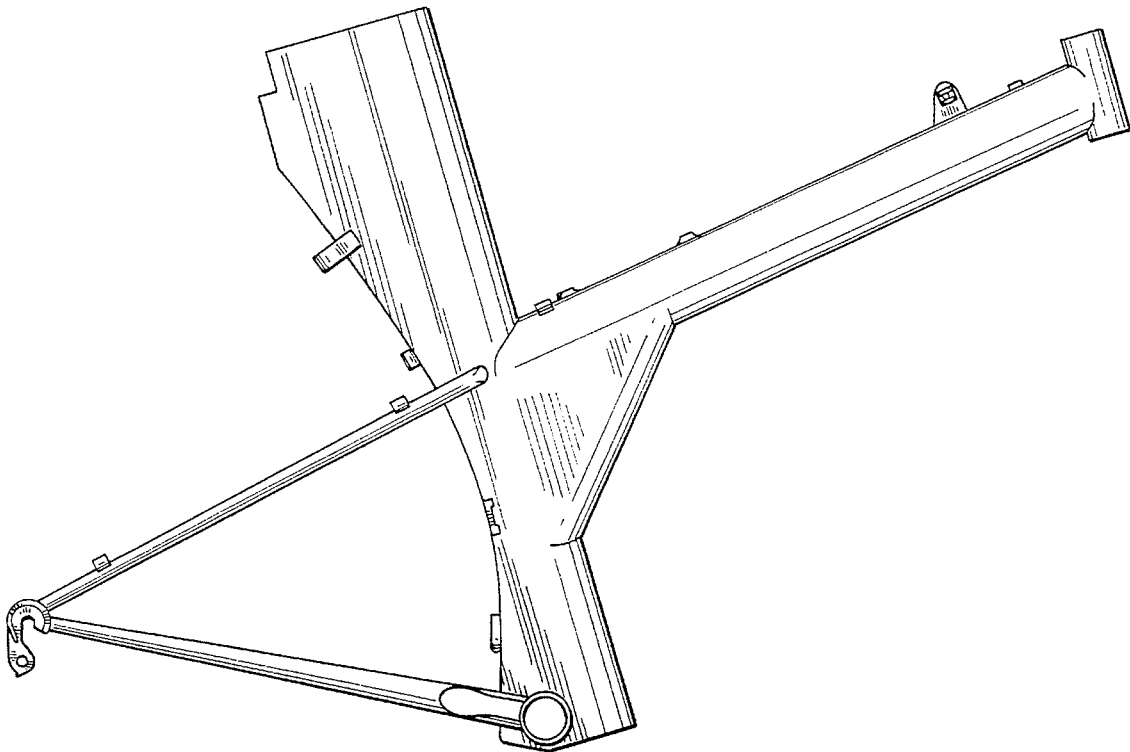

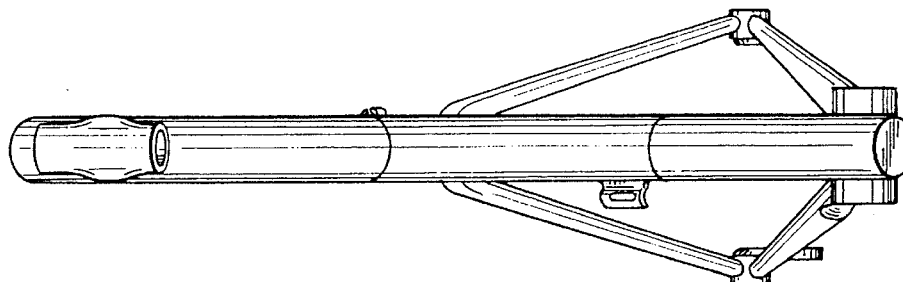

FIG. 2

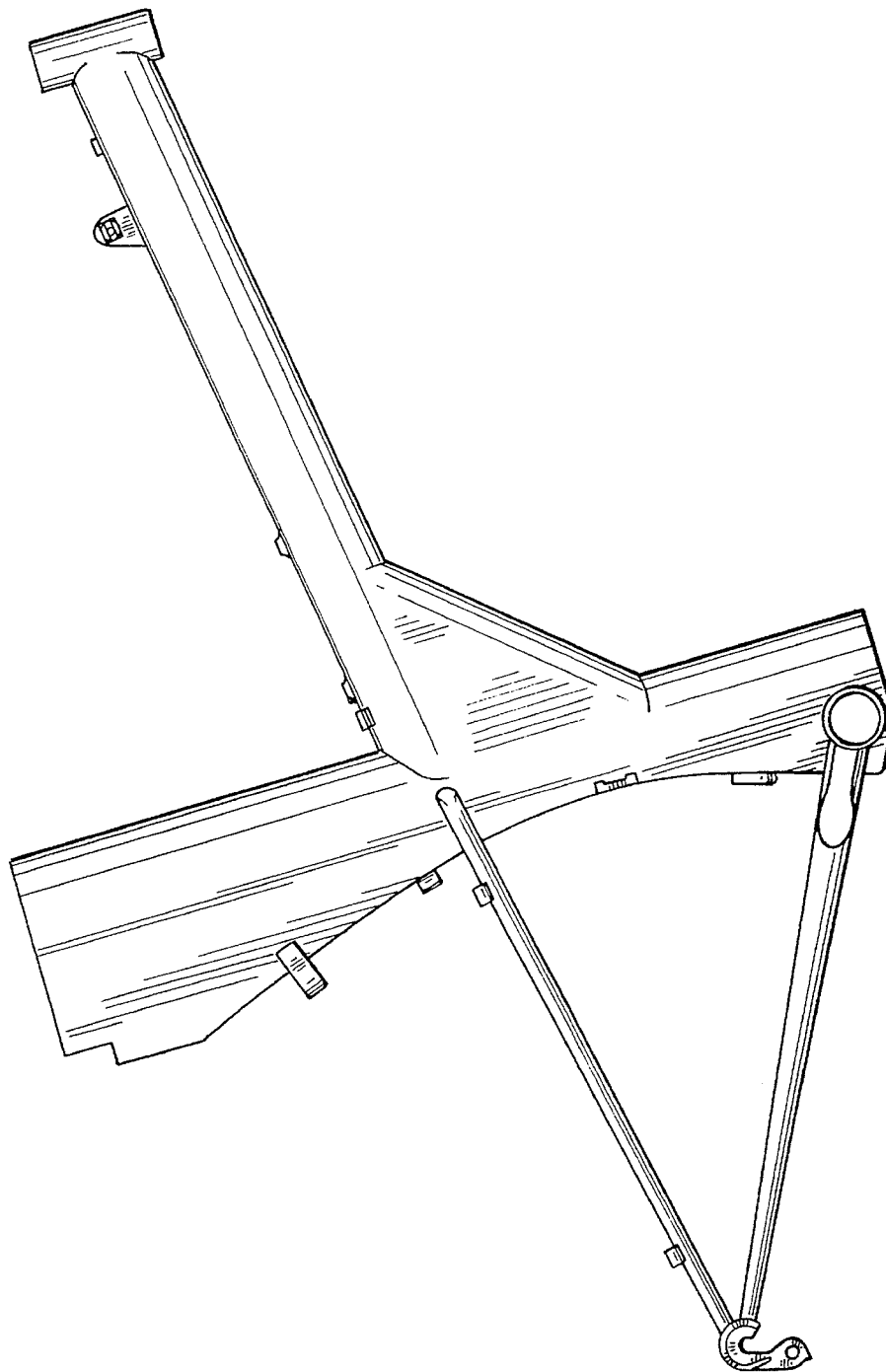
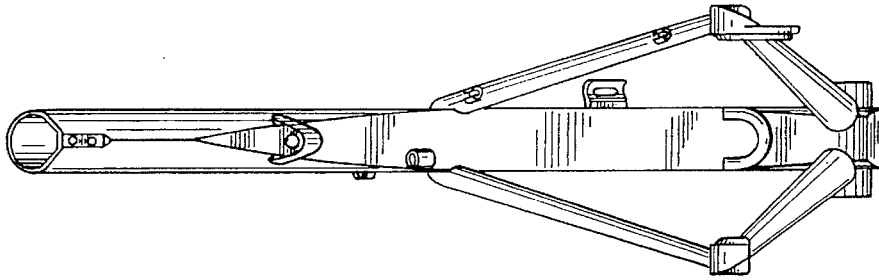
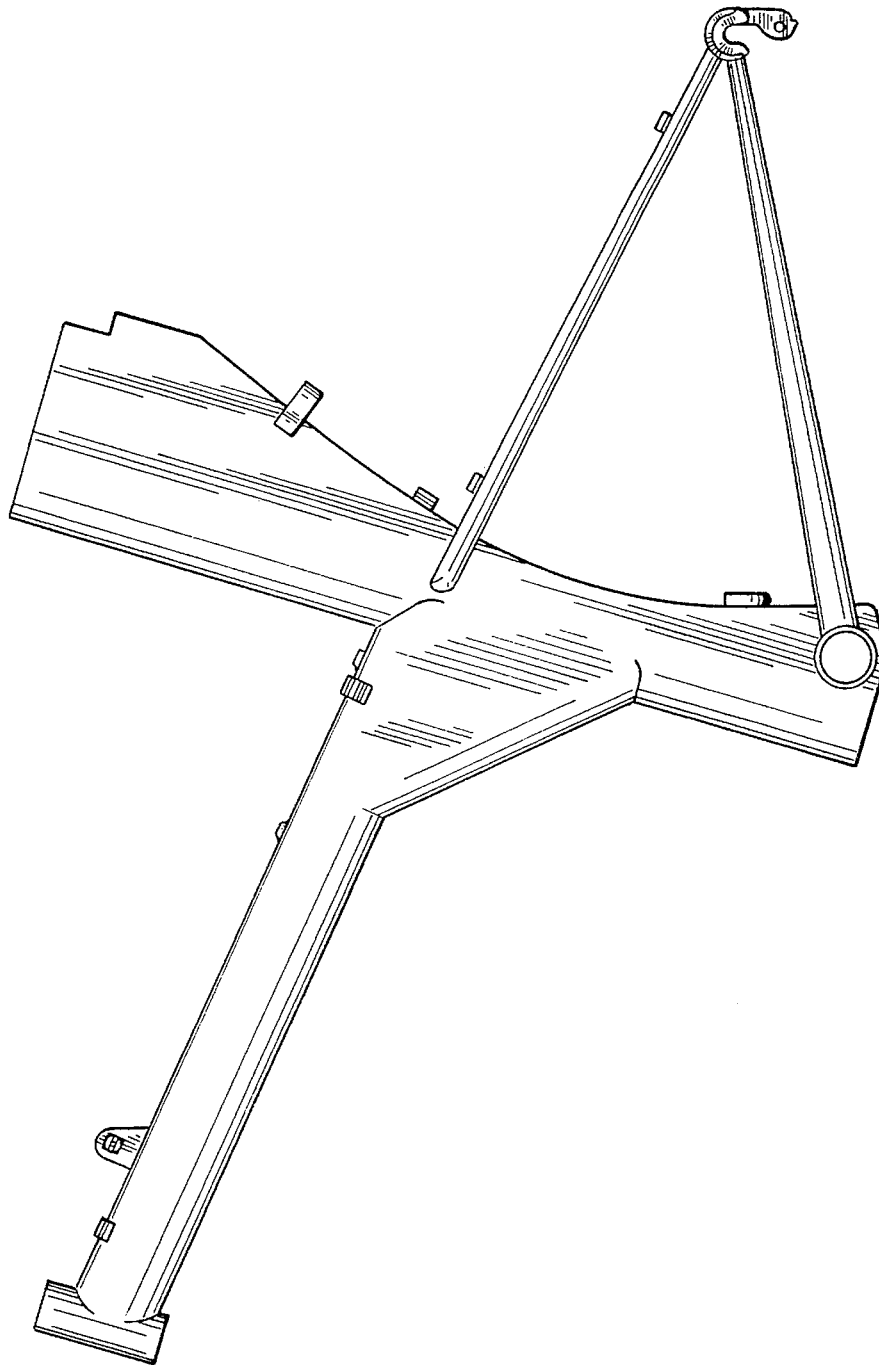

FIG. 1



**FIG. 4**



**FIG. 3**

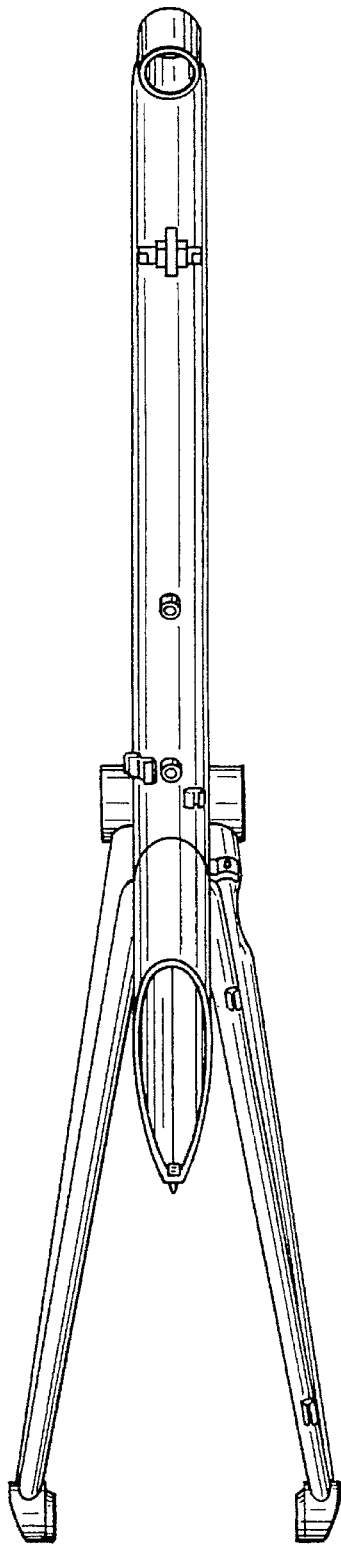

**FIG. 5**

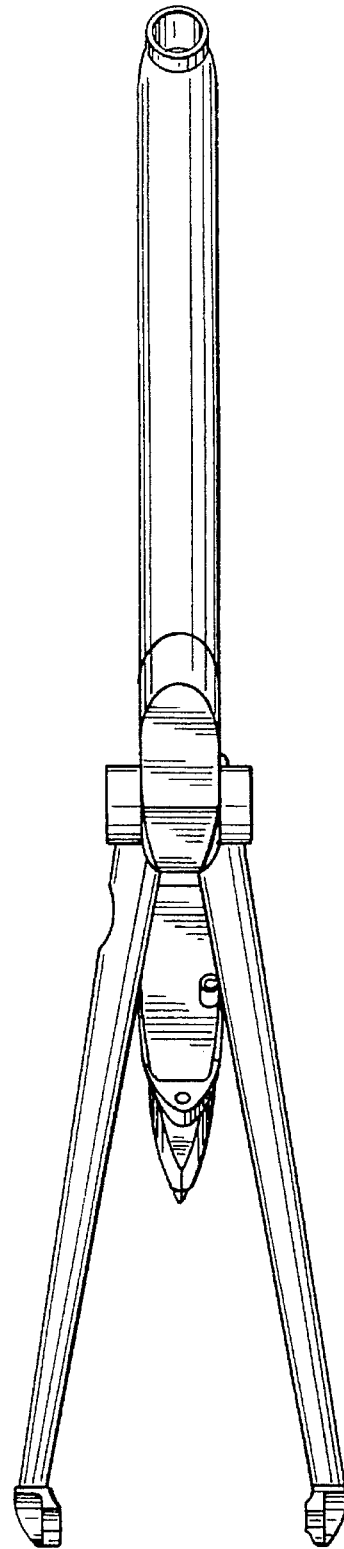

**FIG. 6**