



US00D396831S

United States Patent [19]

[11] Patent Number: **Des. 396,831**

Aprilante et al.

[45] Date of Patent: ****Aug. 11, 1998**

[54] **BICYCLE FRAME**

D. 364,834 12/1995 Dietz et al. D12/111

[75] Inventors: **Monica Duarte Aprilante**, Piracicaba; **Emiliano Martus Barelli**, Araragrara; **Carlos Augusto Magnani Fantinato**, Piracicaba; **Glaucia Nogueira Goncalves**, Sas Paulo; **Fernando M. M. Ribiero**, Carlos; **Marcelo Uller**, Tijuca-Rio DeJaneiro; **Vanie Regina Velloso**; **Alvaro Costa Neto**, both of Sas Carlos, all of Brazil

OTHER PUBLICATIONS

Bicycling, Dec. 1994, p. 48, the "Rubicon Comp" dual-suspension bike.

Primary Examiner—Melody N. Brown
Attorney, Agent, or Firm—C. Michael Gegenheimer; Curtis B. Brueske

[73] Assignee: **Owens-Corning**, Toledo, Ohio

[57] CLAIM

The ornamental design for a bicycle frame, as shown and described.

[**] Term: **14 Years**

DESCRIPTION

[21] Appl. No.: **71,232**

FIG. 1 is a perspective view of a bicycle frame showing our new design, the bicycle parts shown in broken lines are for illustrative purposes only and form no part of the claimed design;

[22] Filed: **May 23, 1997**

FIG. 2 is a right side elevational view of the bicycle frame of **FIG. 1**, with the left side elevational view being a mirror image thereof;

[51] **LOC (6) Cl.** **12-11**

[52] **U.S. Cl.** **D12/111**

[58] **Field of Search** **D12/111; 280/281.1, 280/288.1-288.3**

FIG. 3 is a front elevational view of the bicycle frame of **FIG. 1**;

FIG. 4 is a rear elevational view of the bicycle frame of **FIG. 1**;

FIG. 5 is a top view of the bicycle frame of **FIG. 1**; and **FIG. 6** is a bottom view of the bicycle frame of **FIG. 1**.

[56] References Cited

U.S. PATENT DOCUMENTS

- D. 313,381 1/1991 Moeller D12/111
- D. 349,869 8/1994 Burrows et al. D12/111
- D. 364,128 11/1995 Haney et al. D12/111

1 Claim, 5 Drawing Sheets

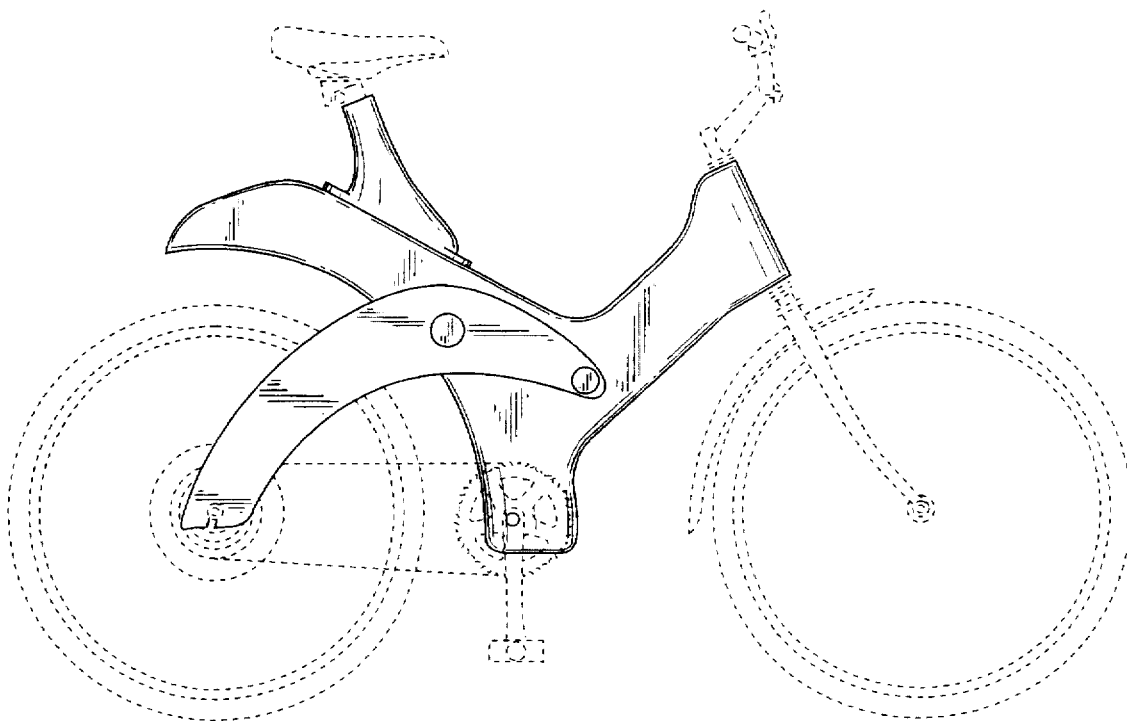

FIG. 1

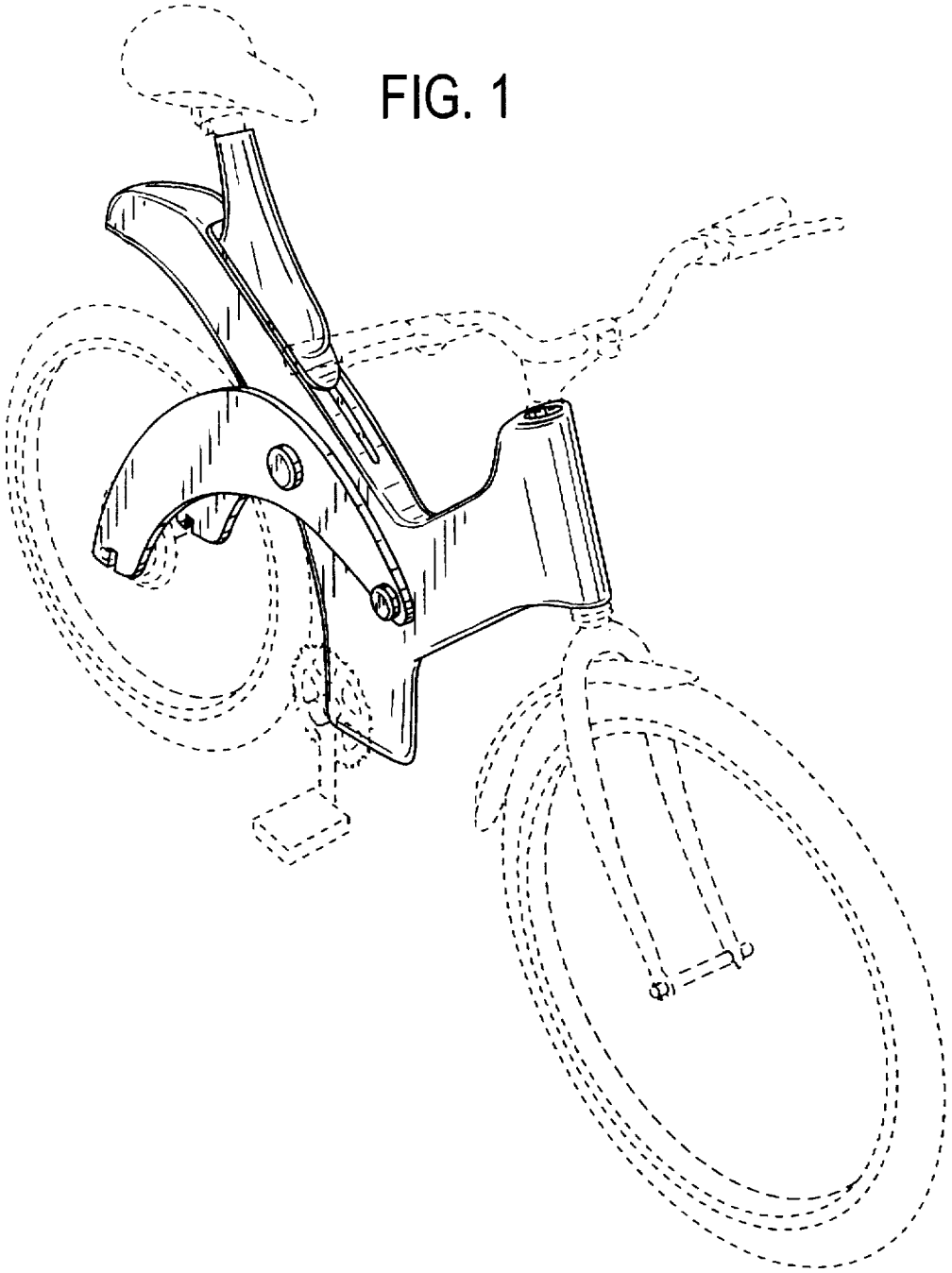

FIG. 2

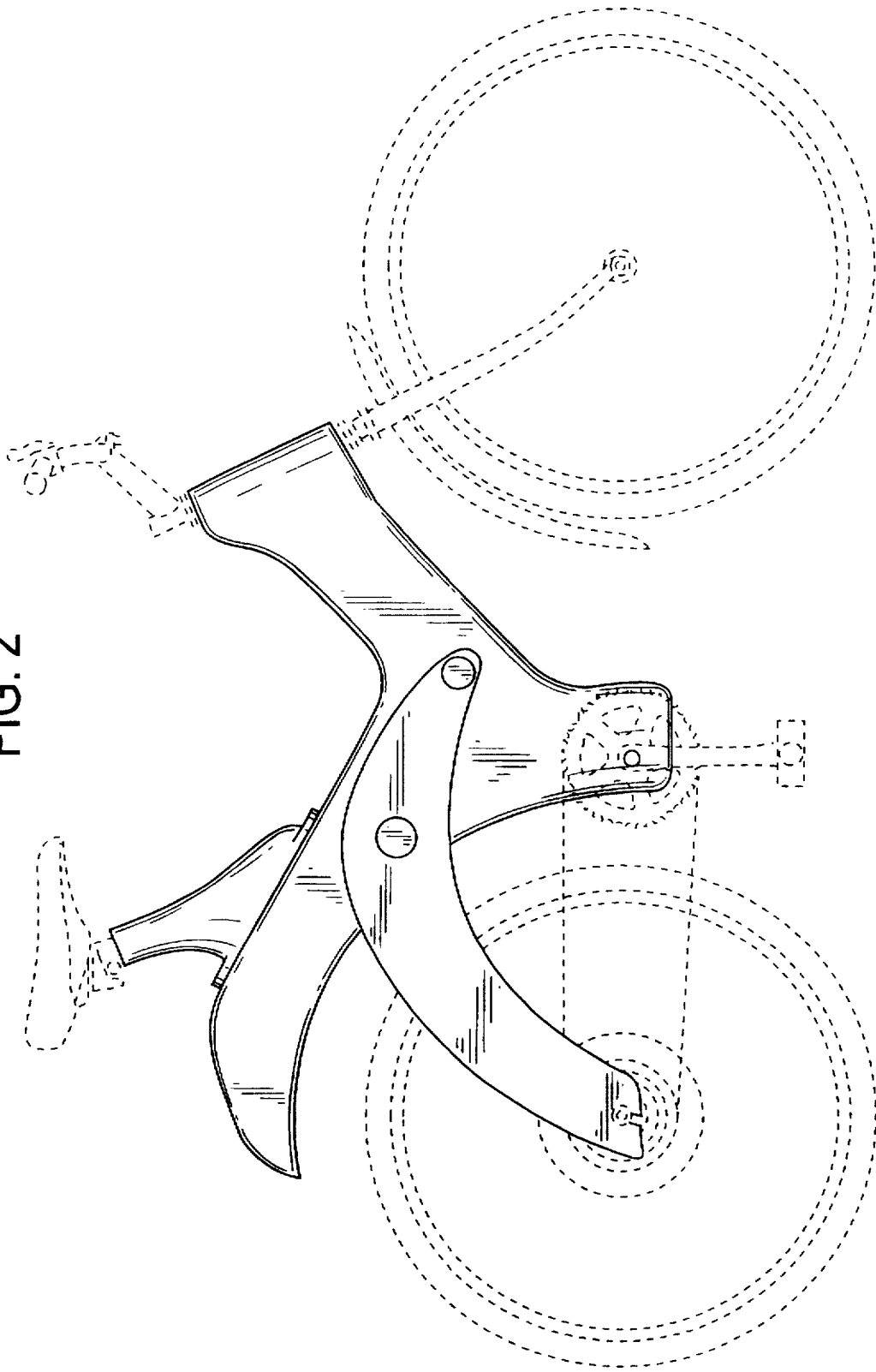

FIG. 4

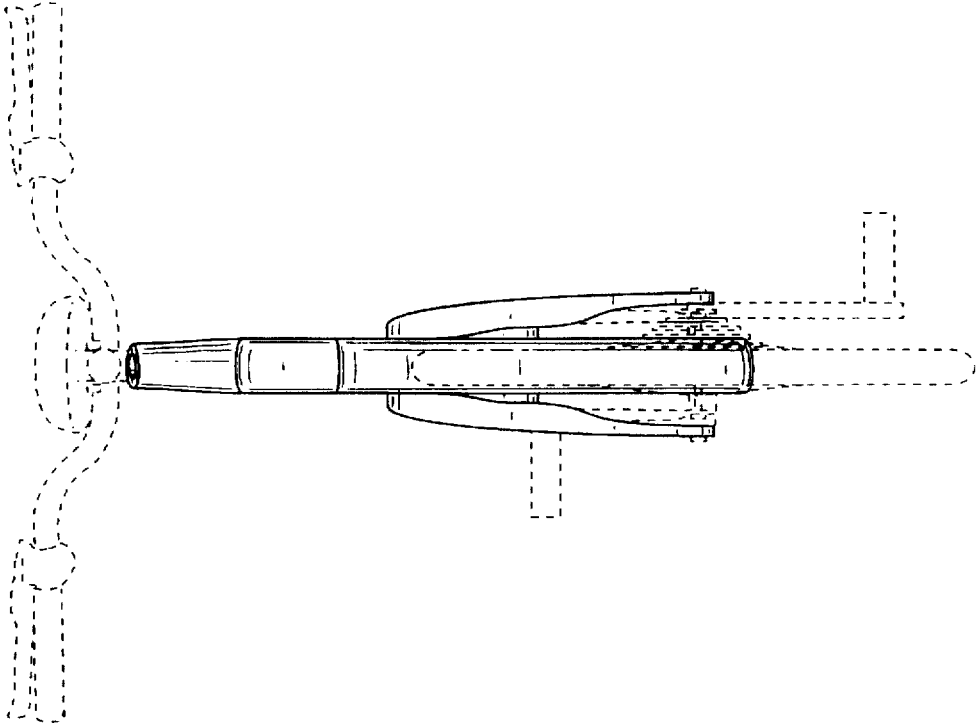
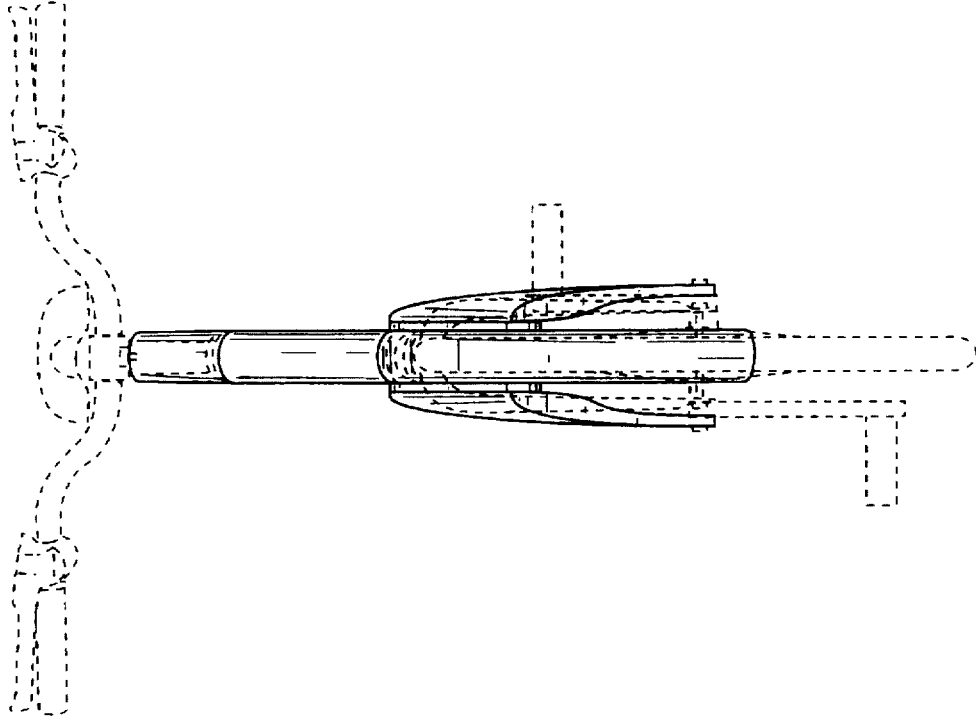
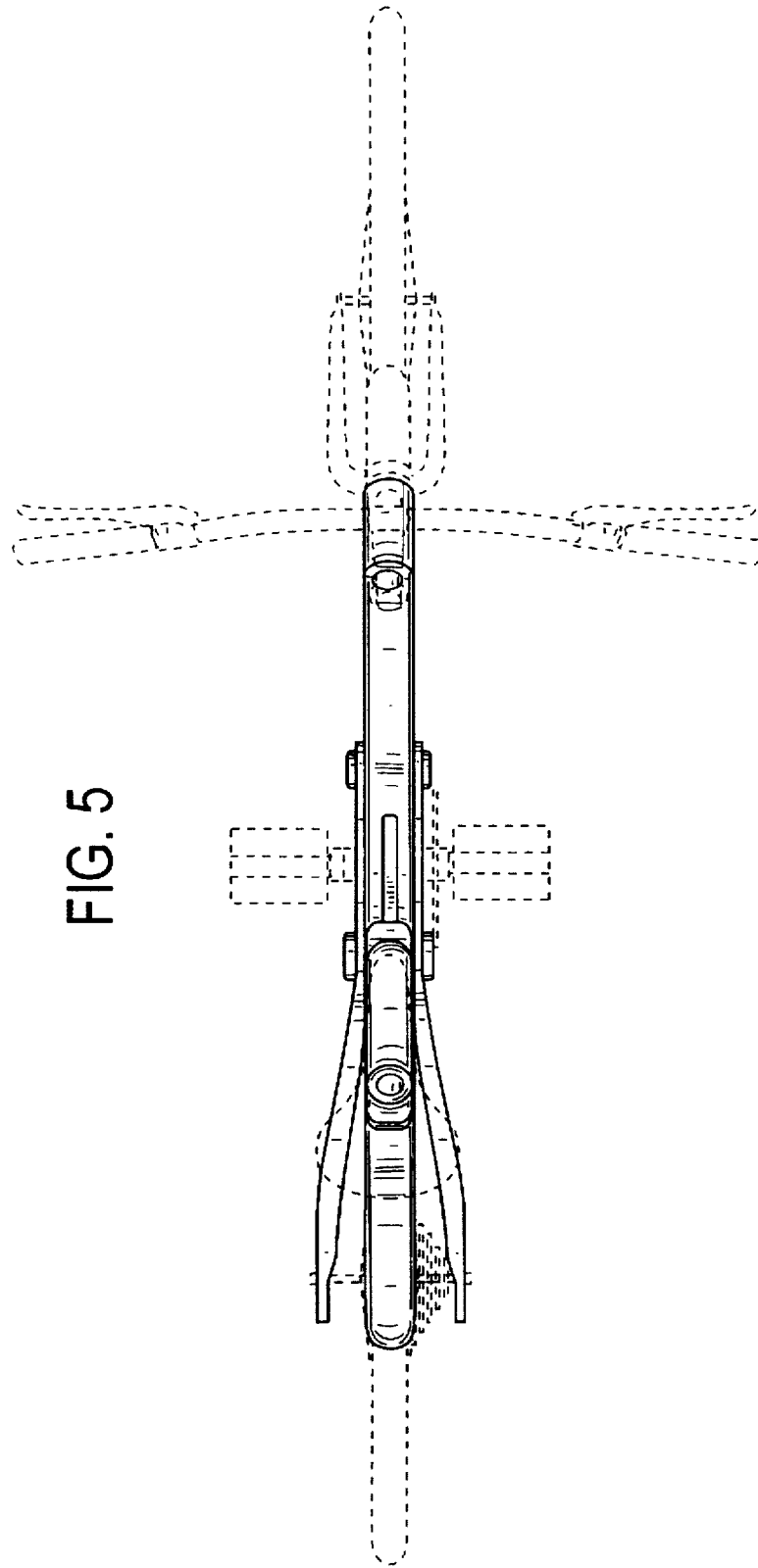

FIG. 3





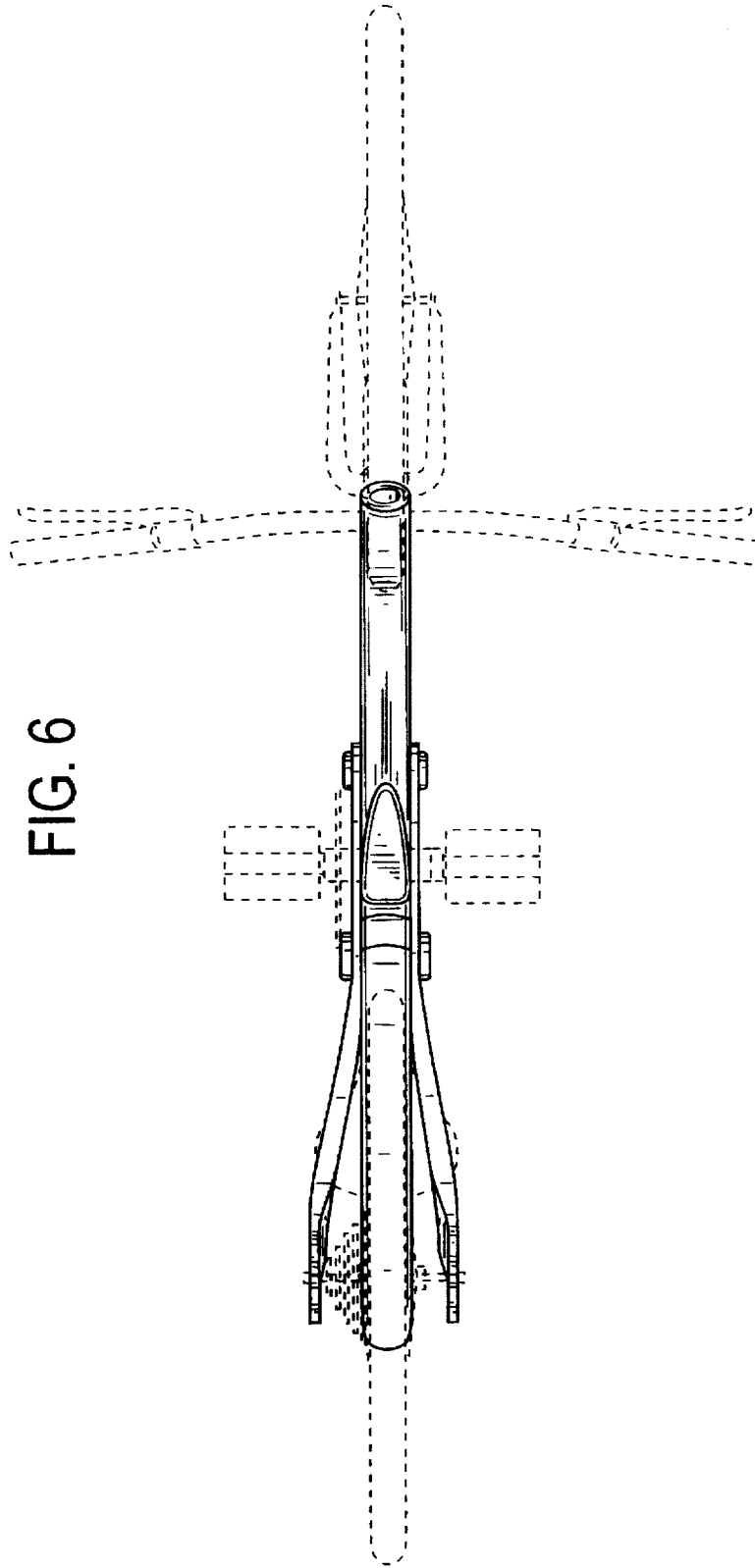

FIG. 6