



US00D401187S

United States Patent [19]

[11] **Patent Number:** **Des. 401,187**

Ninic et al.

[45] **Date of Patent:** ****Nov. 17, 1998**

[54] **BICYCLE FRAME**

[75] Inventors: **Michael Ninic**, Landsberg; **Kris Tomasson**, Munich, both of Germany

[73] Assignee: **Bayerische Motoren Werke Aktiengesellschaft**, Munich, Germany

[**] Term: **14 Years**

[21] Appl. No.: **59,730**

[22] Filed: **Sep. 5, 1996**

[30] **Foreign Application Priority Data**

Mar. 5, 1996 [DE] Germany M 96 02 195.0

[51] **LOC (6) Cl.** **12-11**

[52] **U.S. Cl.** **D12/111**

[58] **Field of Search** D12/111; 280/281.1, 280/288.1-288.3

[56] **References Cited**

U.S. PATENT DOCUMENTS

- D. 354,934 1/1995 Johnson D12/111
- D. 363,050 10/1995 Wang et al. D12/111
- D. 377,465 1/1997 Keiuk D12/111
- D. 377,469 1/1997 Keiuk D12/111

Primary Examiner—Melody N. Brown
Attorney, Agent, or Firm—Evenson, McKeown, Edwards & Lenahan, P.L.L.C.

[57] **CLAIM**

The ornamental design for a bicycle frame, as shown and described.

DESCRIPTION

FIG. 1 is a left-front perspective view of a bicycle frame according to our novel design;
 FIG. 2 is a right-front perspective view of a bicycle frame according to our novel design;
 FIG. 3 is a left-rear perspective view of a bicycle frame according to our novel design;
 FIG. 4 is a right-rear perspective view of a bicycle frame according to our novel design;
 FIG. 5 is a left side view of a bicycle frame according to our novel design;
 FIG. 6 is a right side view of a bicycle frame according to our novel design;
 FIG. 7 is a front view of a bicycle frame according to our novel design;
 FIG. 8 is a rear view of a bicycle frame, according to our novel design;
 FIG. 9 is a top view of a bicycle frame, according to our novel design; and,
 FIG. 10 is a bottom view of a bicycle frame, according to our novel design.

The broken lines shown in all views of the drawings are for illustrative purposes only and form no part of the claimed design.

1 Claim, 9 Drawing Sheets

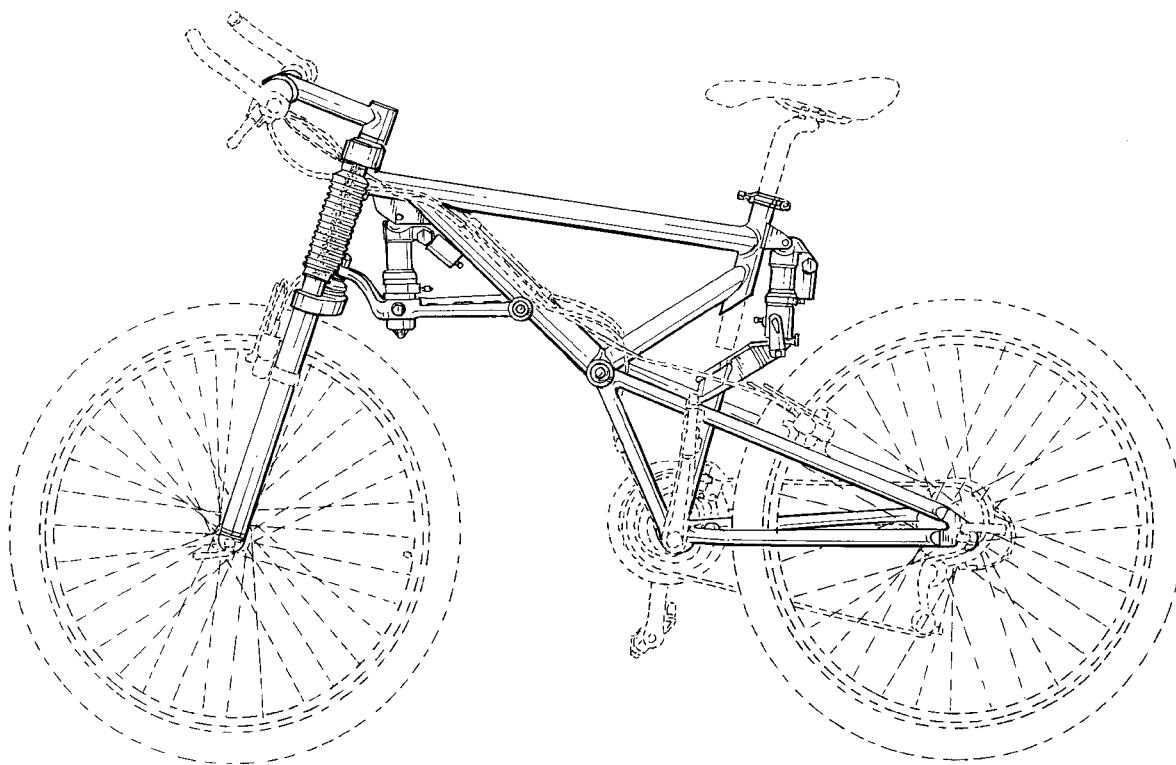

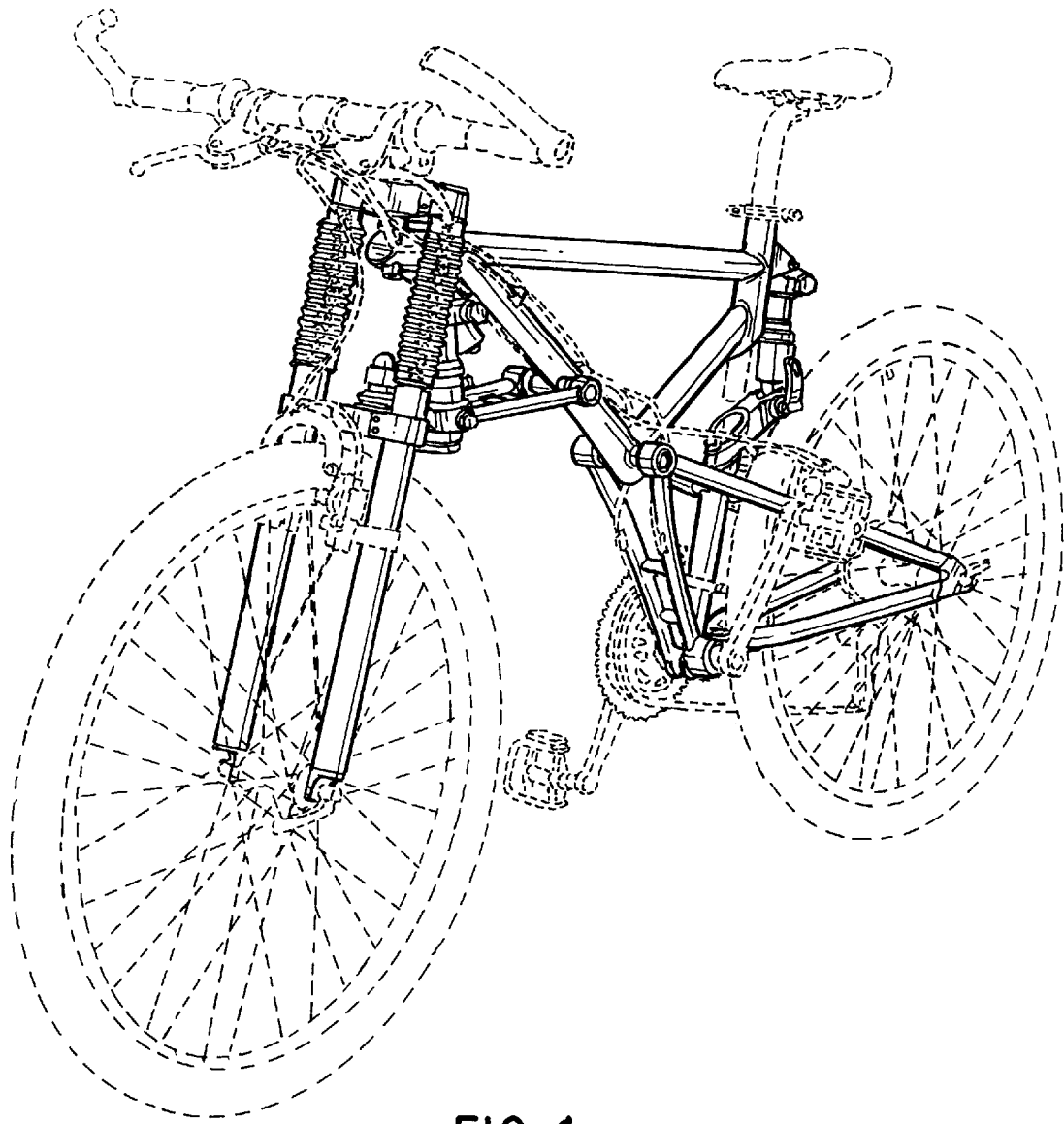

FIG. 1

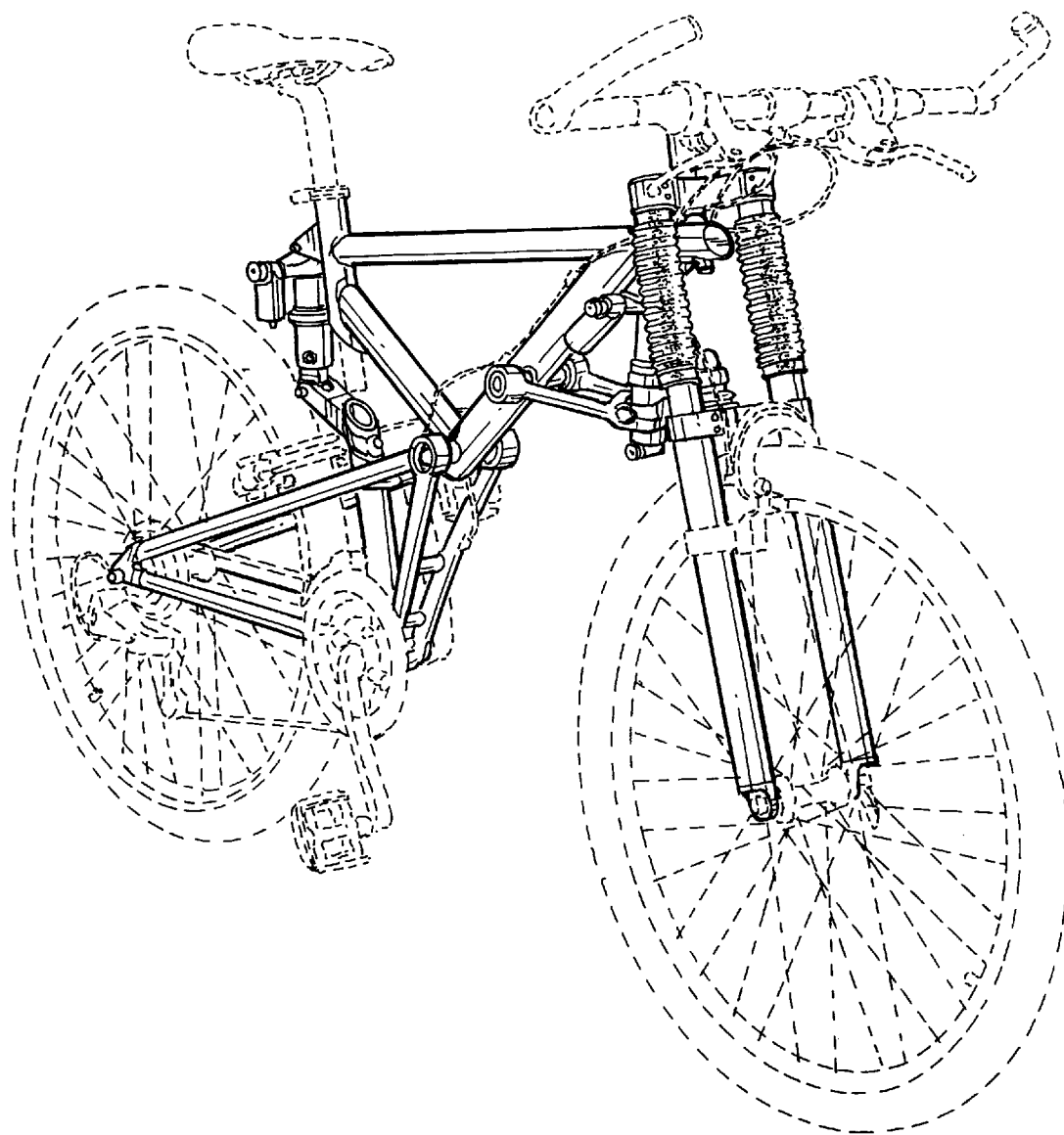

FIG. 2

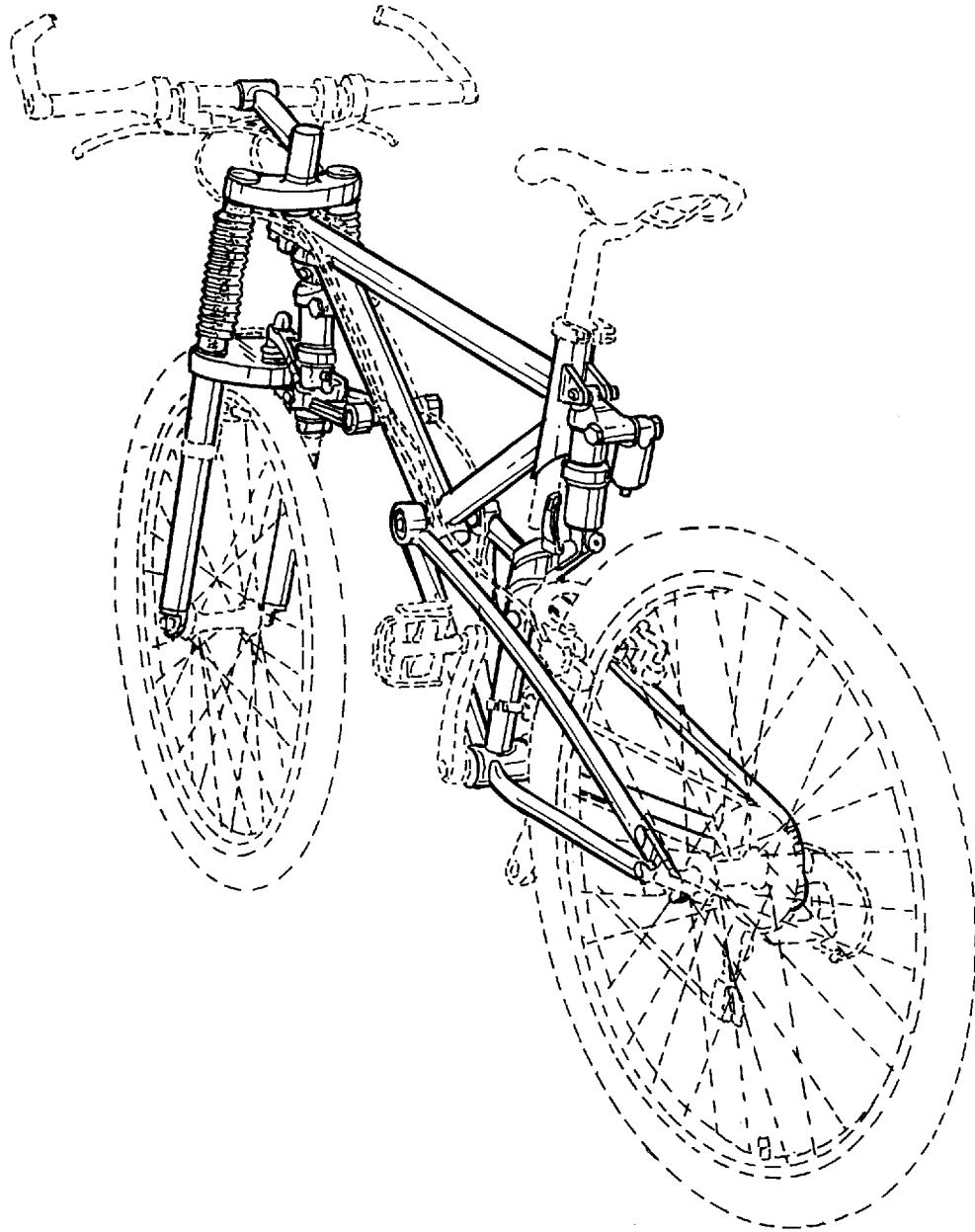

FIG. 3



FIG. 4

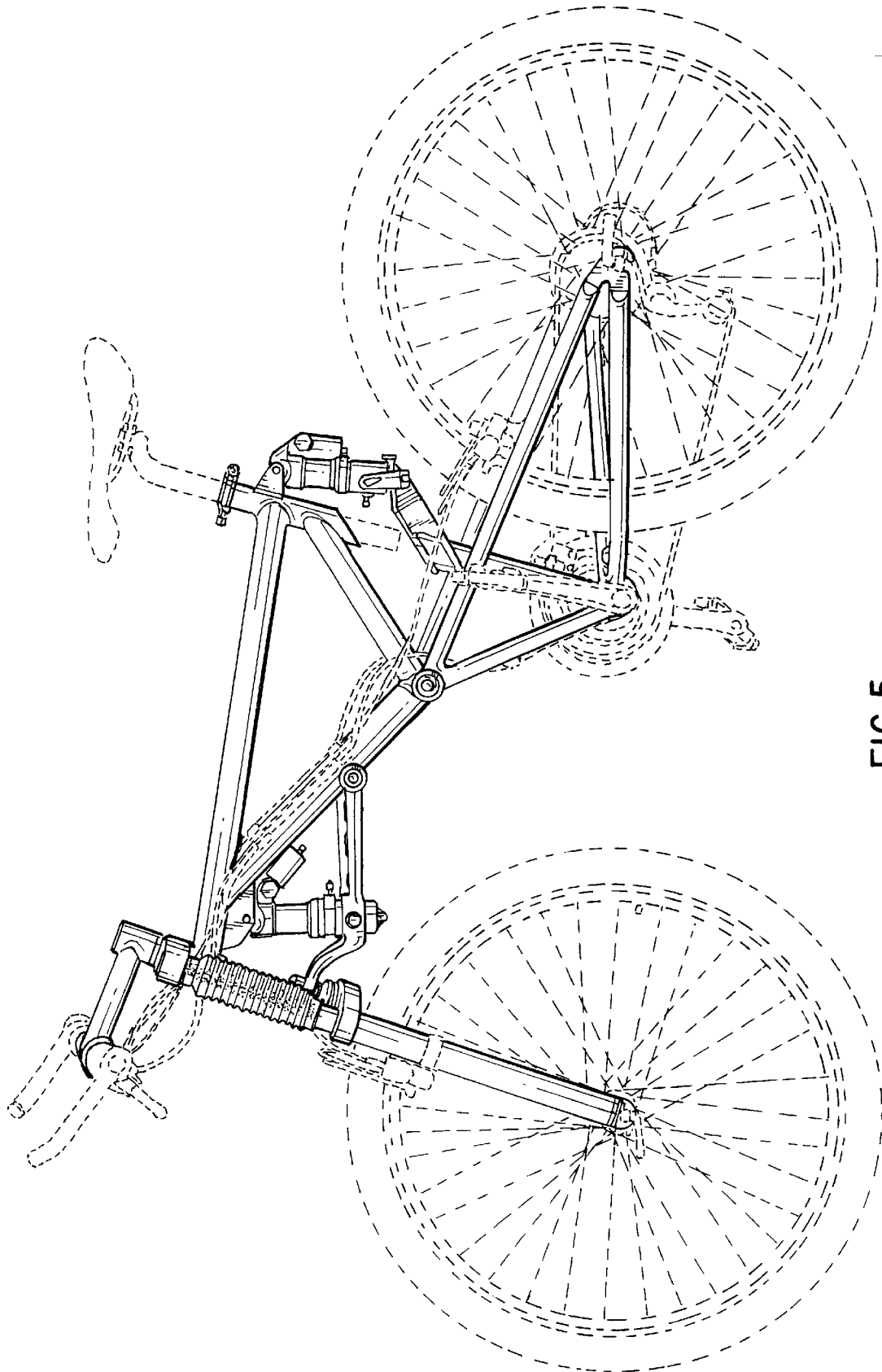

FIG. 5

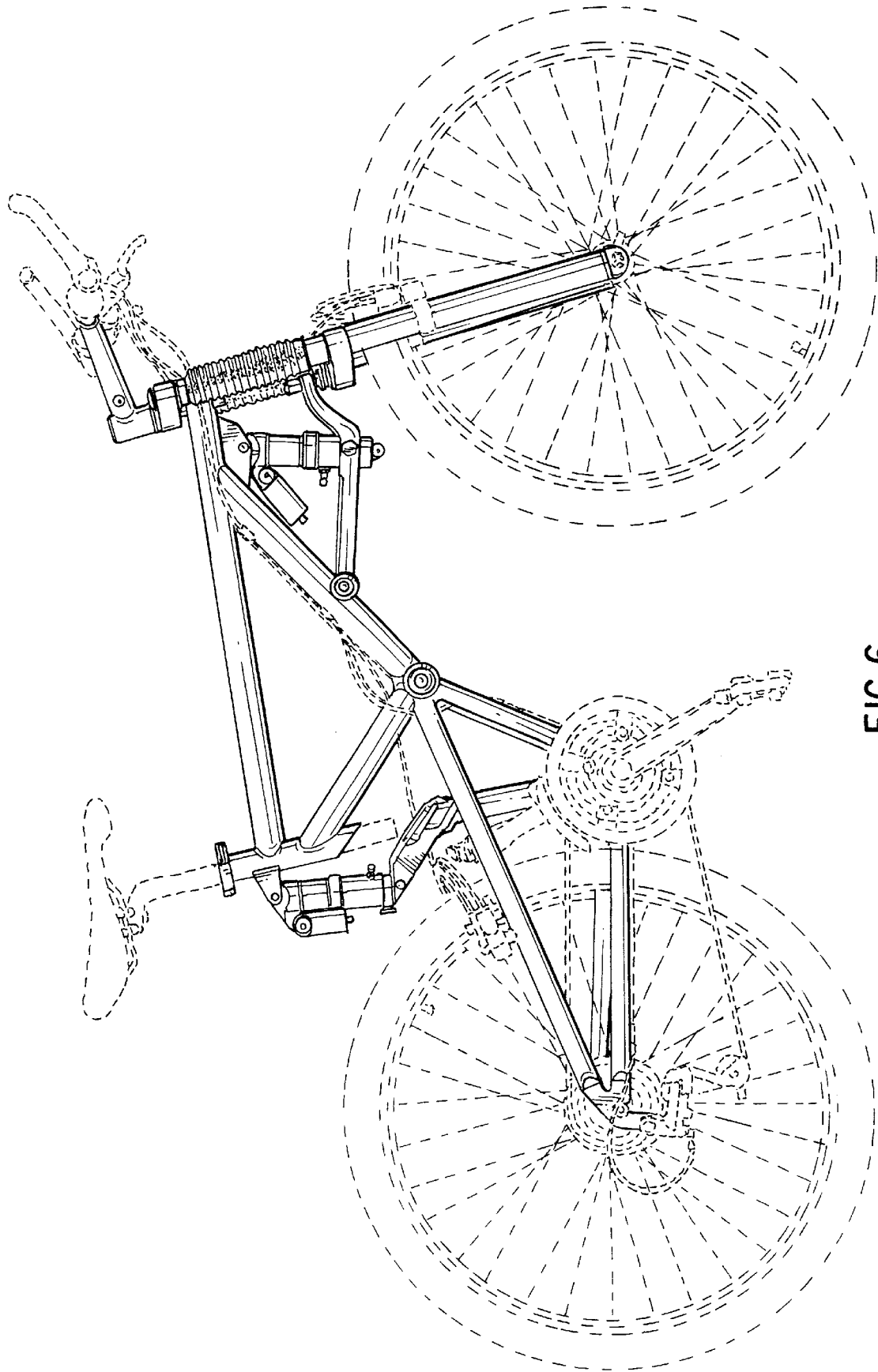

FIG. 6

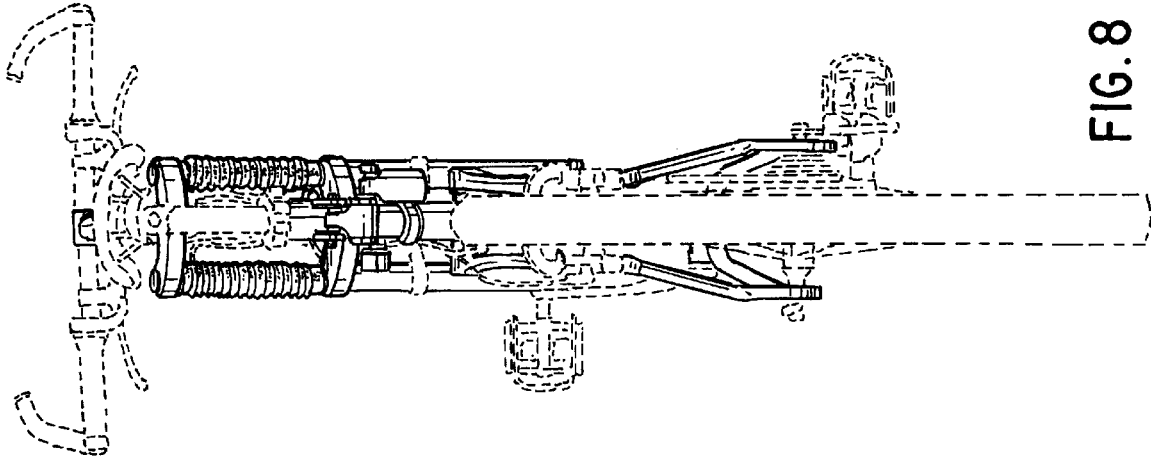

FIG. 8

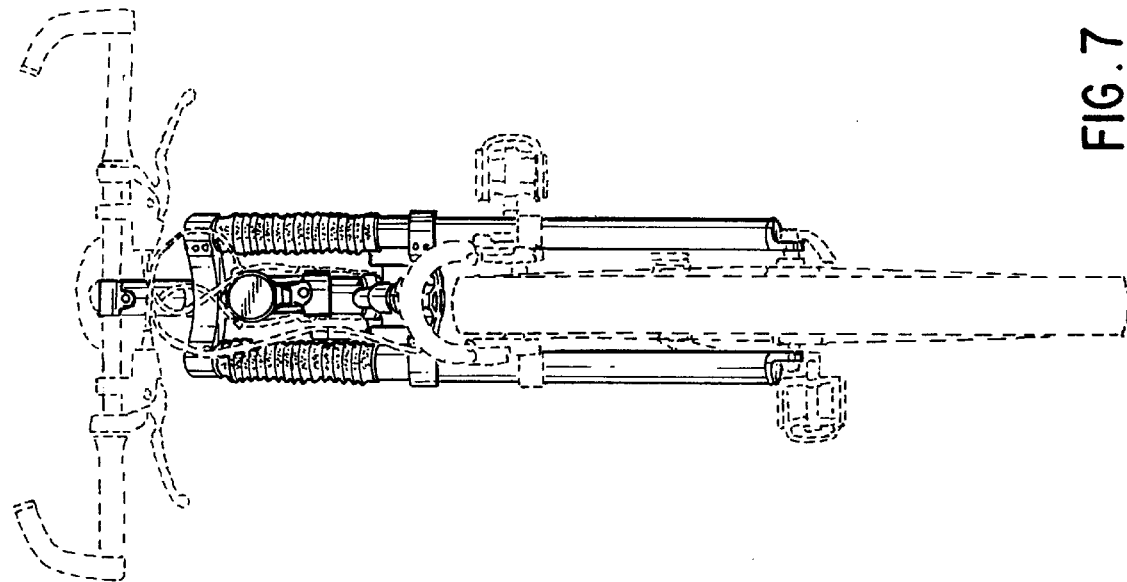

FIG. 7

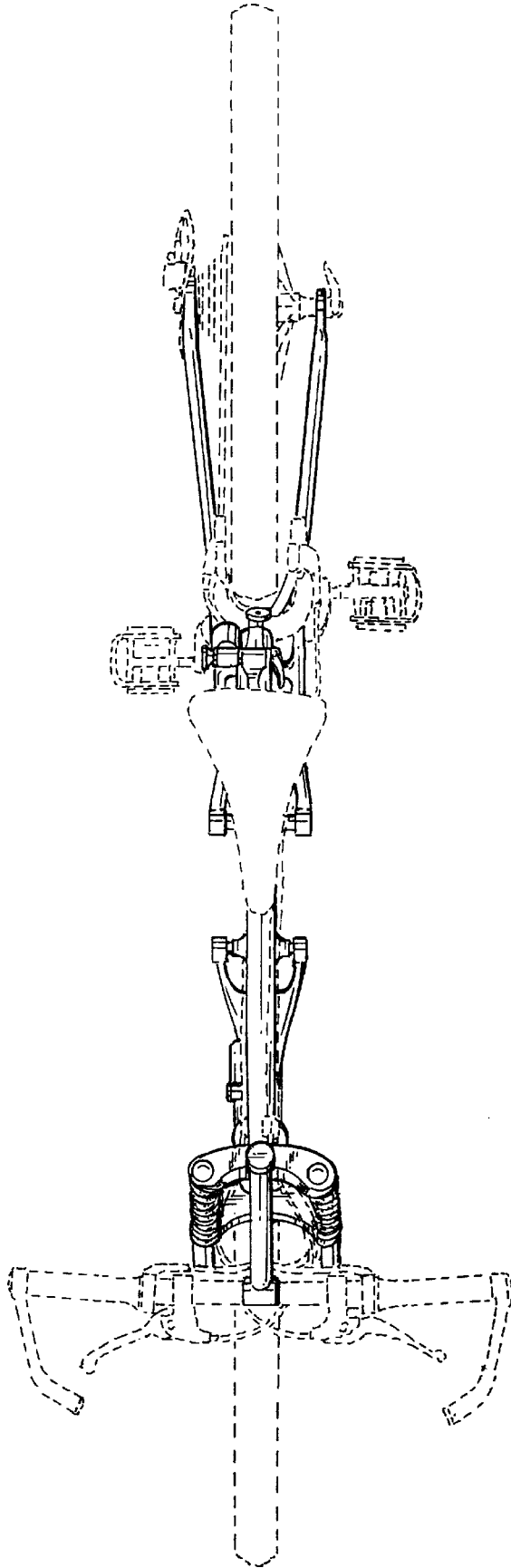

FIG. 9

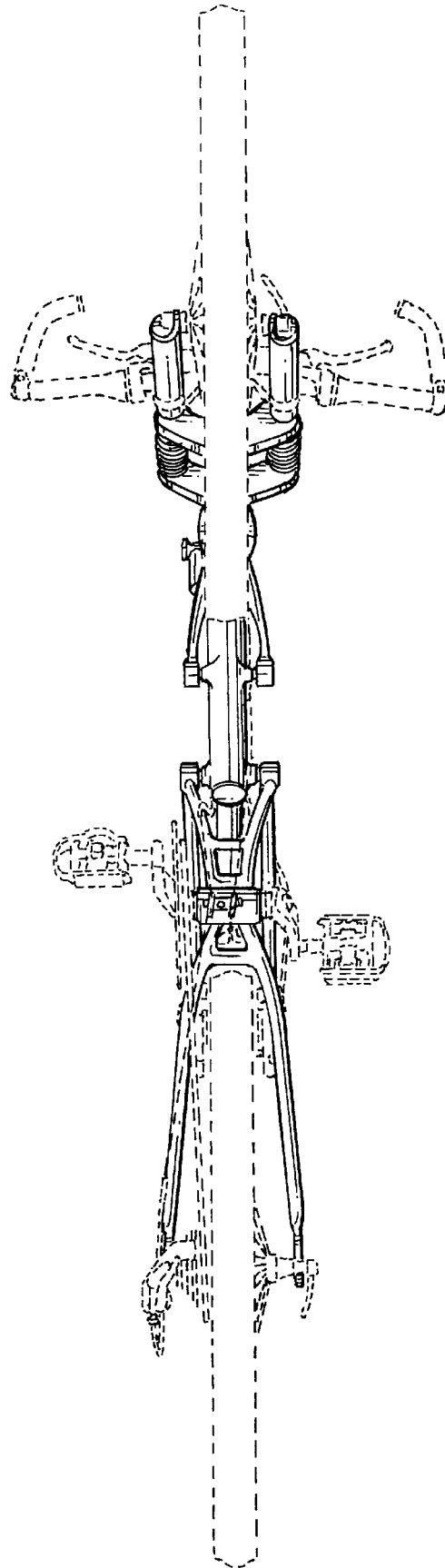

FIG. 10