



US00D505891S

(12) **United States Design Patent**
Drew et al.

(10) **Patent No.:** US D505,891 S
(45) **Date of Patent:** ** Jun. 7, 2005

(54) **BICYCLE FRAME**

(76) Inventors: **Errol Drew**, 10 Smith Court,
Southbridge (GB), NN4 8GF; **Philip
Justin Karl**, 234 Williams St.,
Providence, RI (US) 02906

(**) Term: **14 Years**

(21) Appl. No.: **29/200,643**

(22) Filed: **Mar. 1, 2004**

(51) **LOC (8) Cl.** **12-11**

(52) **U.S. Cl.** **D12/111**

(58) **Field of Search** D12/111, 117;
280/274-280, 281.1, 283-288, 288.1-288.4

(56) **References Cited**

U.S. PATENT DOCUMENTS

3,195,923 A	*	7/1965	Moulton	280/281.1
4,809,999 A	*	3/1989	Tozawa et al.	280/281.1
5,211,415 A	*	5/1993	Gasiorowski	280/281.1
D390,505 S	*	2/1998	Shiau	D12/111

* cited by examiner

Primary Examiner—Alan P. Douglas

Assistant Examiner—Linda Brooks

(74) *Attorney, Agent, or Firm*—David J. Rikkers; Brown
Rudnick Berlack Israels LLP

(57) **CLAIM**

The ornamental design for a bicycle frame, as shown and
described.

DESCRIPTION

FIG. 1 is a right side elevation of a bicycle frame according
to our new design having a protruding, tapered side contour,
shown as might optionally be used with surrounding structure;

FIG. 2 is a top elevation of a bicycle frame according to our
new design;

FIG. 3 is a bottom elevation thereof;

FIG. 4 is a front elevation thereof; and,

FIG. 5 is a back elevation thereof.

The left side elevation of a bicycle frame according to our
new design is a mirror of the bicycle frame illustrated in
FIG. 1.

1 Claim, 2 Drawing Sheets

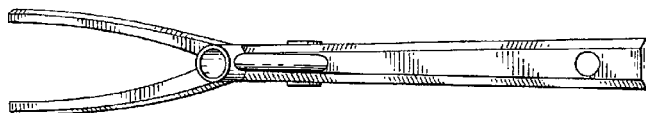
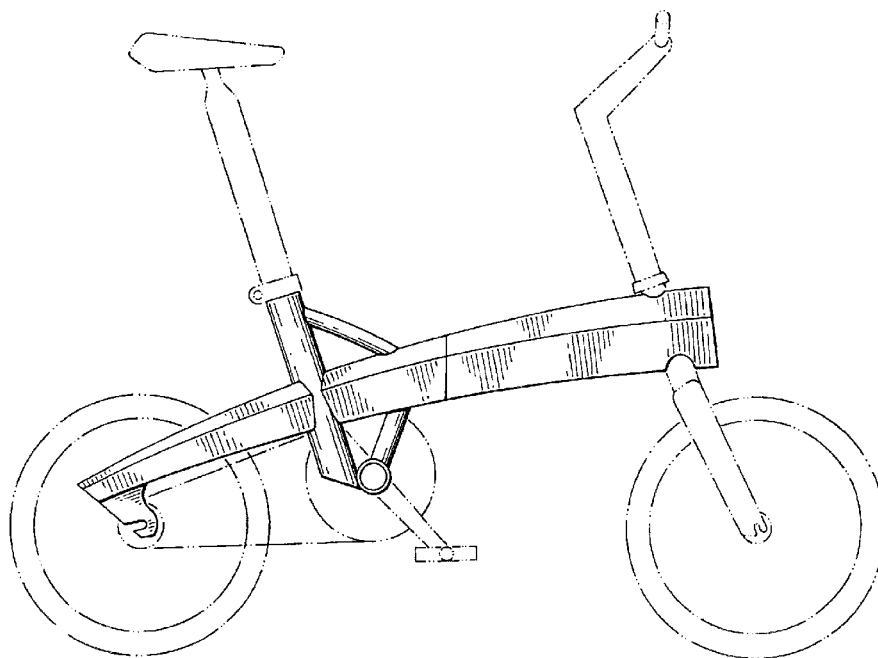

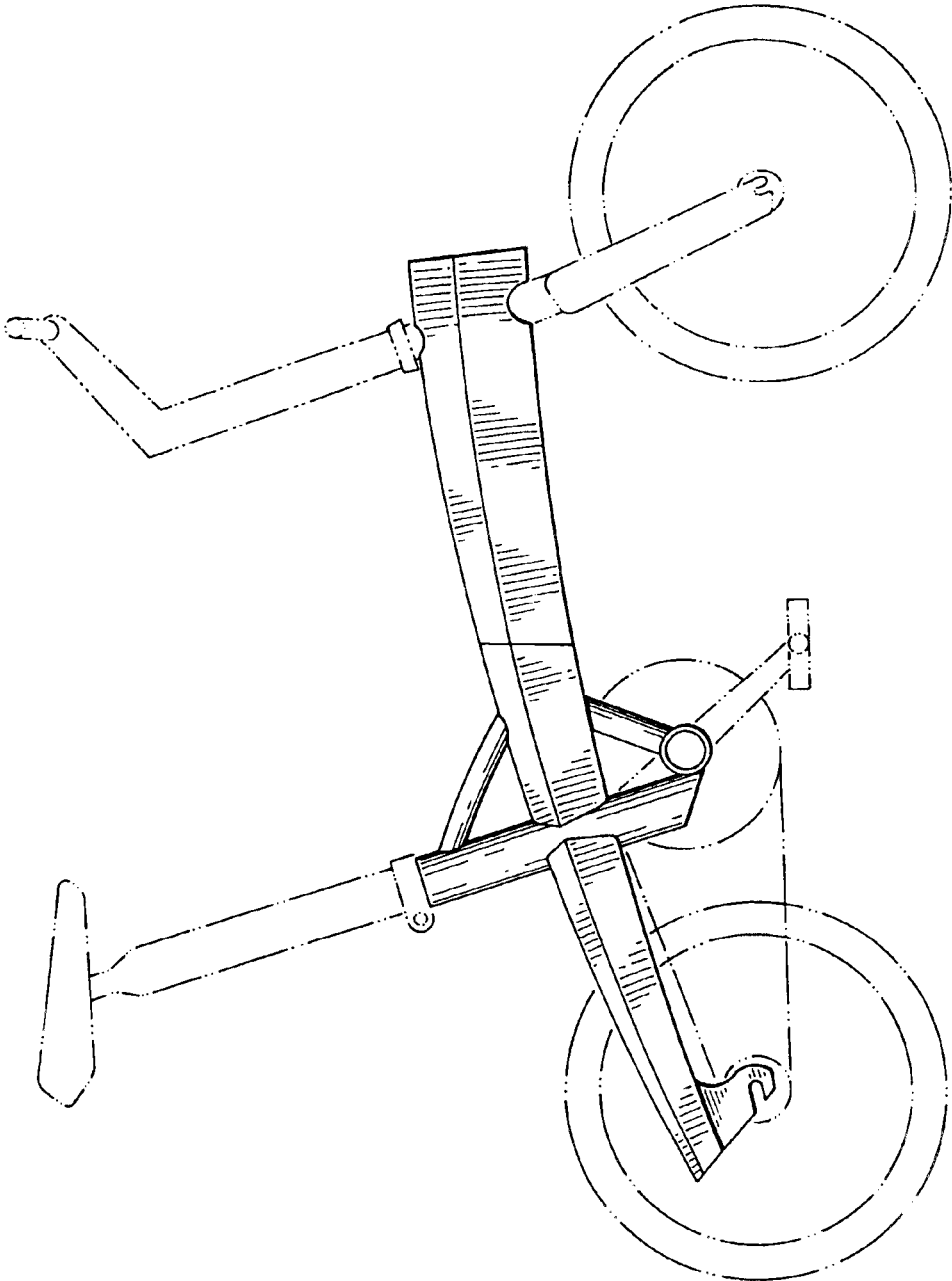

Fig. 1

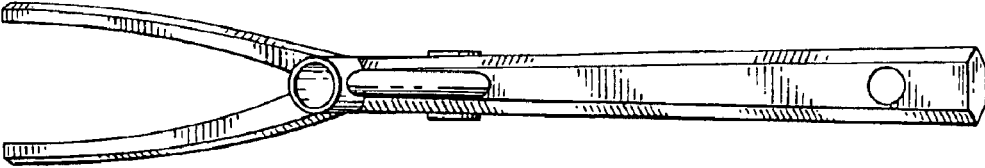

Fig. 2

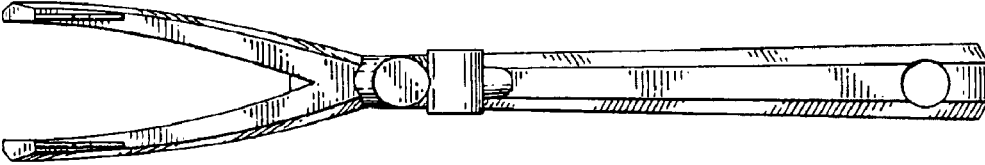

Fig. 3

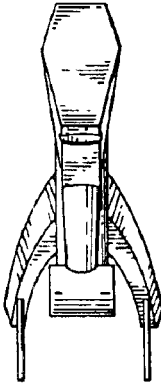

Fig. 4

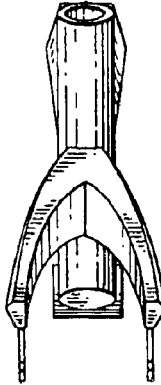

Fig. 5