



US00D522411S

(12) **United States Design Patent**
Comair et al.

(10) **Patent No.:** **US D522,411 S**

(45) **Date of Patent:** **** Jun. 6, 2006**

(54) **RECUMBENT BICYCLE FRAME**

(75) Inventors: **Claude Boutros Comair**, Bellevue, WA (US); **Joel Norman Smith**, Edmonds, WA (US)

(73) Assignee: **Cro-Magnon Mechanics LLC**, Redmond, WA (US)

(**) Term: **14 Years**

(21) Appl. No.: **29/219,316**

(22) Filed: **Dec. 15, 2004**

(51) **LOC (8) Cl.** **12-11**

(52) **U.S. Cl.** **D12/111**

(58) **Field of Classification Search** D12/111,
D12/107; 280/274-278, 288.1-288.3, 281.1,
280/283-288, 263, 267

See application file for complete search history.

(56) **References Cited**

U.S. PATENT DOCUMENTS

D327,040 S * 6/1992 Brummer D12/111
D428,830 S * 8/2000 Brummer D12/111

* cited by examiner

Primary Examiner—Alan P. Douglas

Assistant Examiner—Linda Brooks

(74) *Attorney, Agent, or Firm*—Christensen O'Connor Johnson Kindness PLLC

(57) **CLAIM**

The ornamental design for a recumbent bicycle frame, as shown and described.

DESCRIPTION

FIG. 1 is a perspective view of a recumbent bicycle frame; FIG. 2 is a top view of the recumbent bicycle frame of FIG. 1;

FIG. 3 is a bottom view of the recumbent bicycle frame of FIG. 1;

FIG. 4 is a front elevational view of the recumbent bicycle frame of FIG. 1;

FIG. 5 is a rear elevational view of the recumbent bicycle frame of FIG. 1;

FIG. 6 is a side elevational view of the recumbent bicycle frame of FIG. 1; and,

FIG. 7 is a side elevational view of the recumbent bicycle frame of FIG. 1 taken from the side opposite that of FIG. 6.

1 Claim, 5 Drawing Sheets

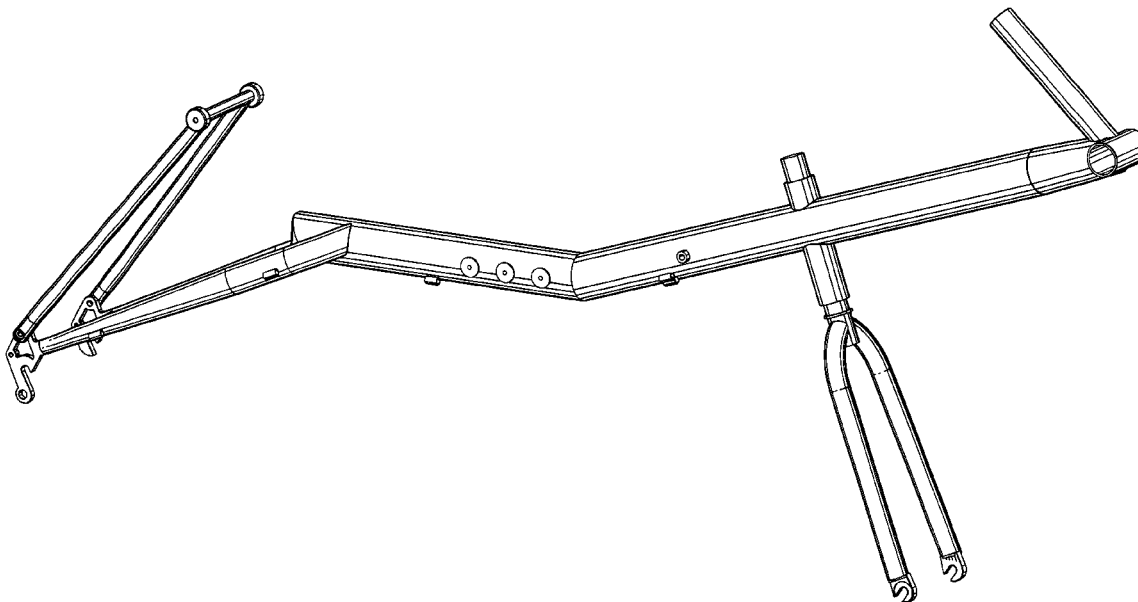

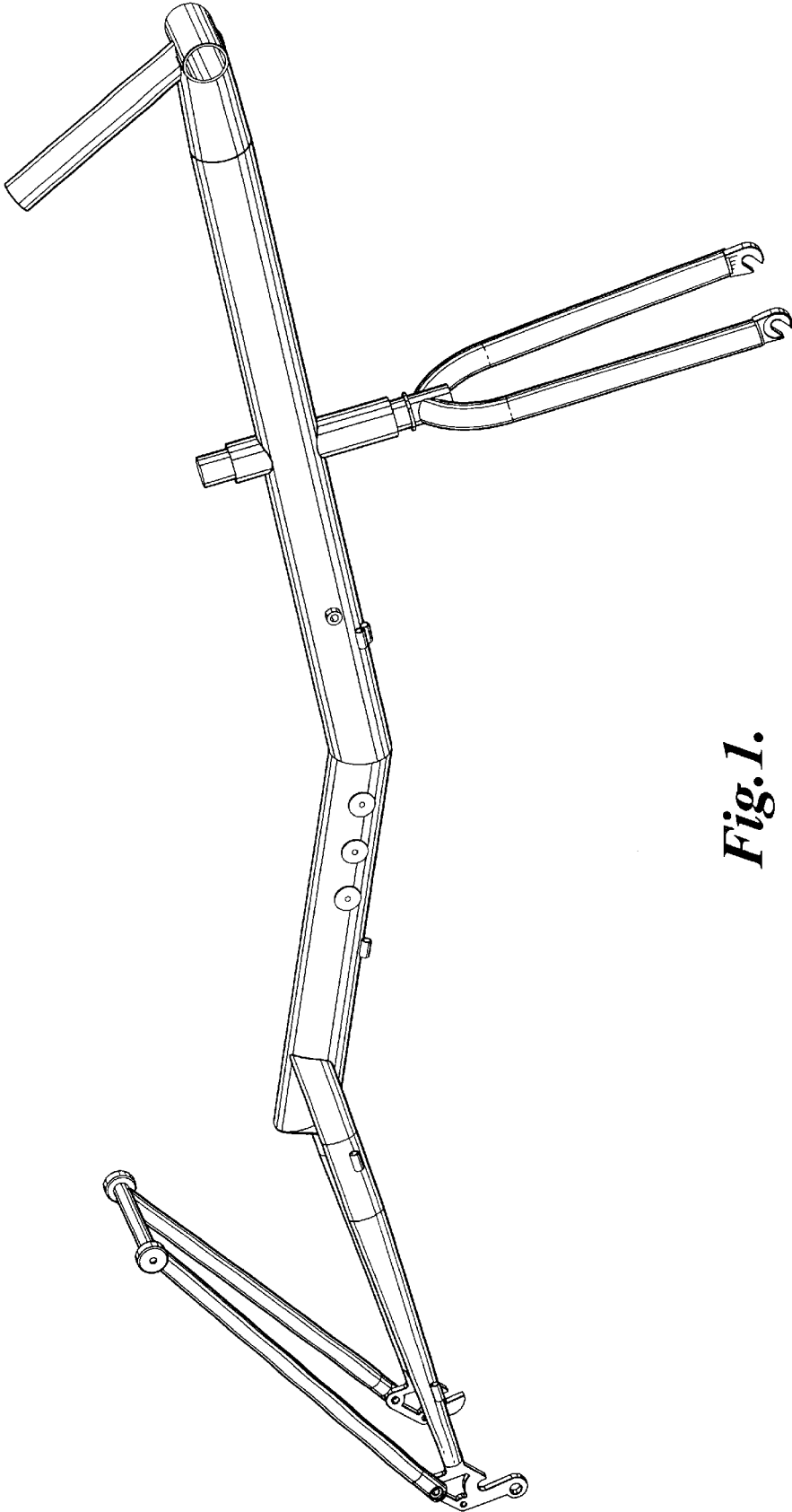

Fig. 1.

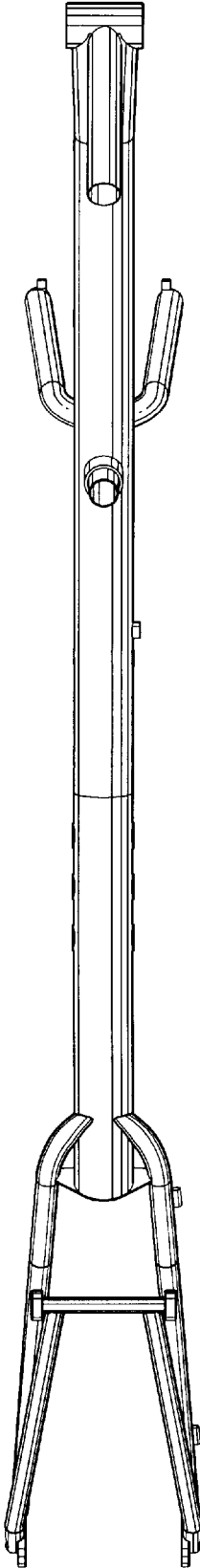

Fig. 2.

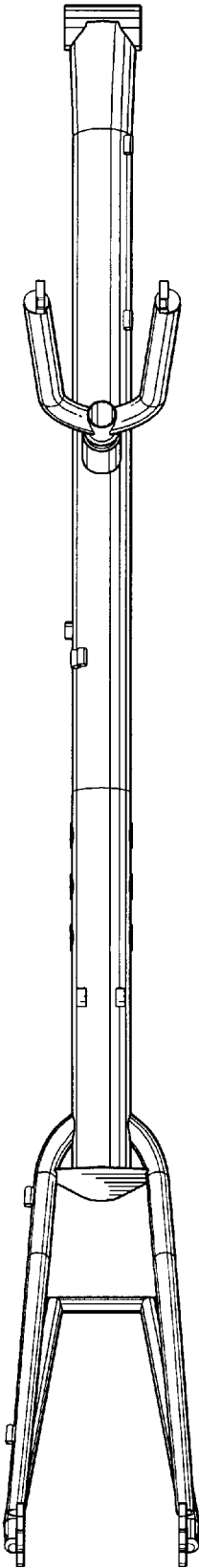

Fig. 3.

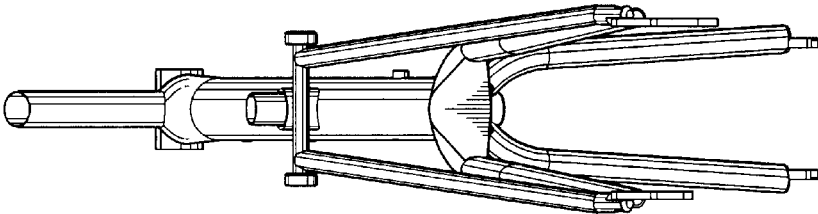

Fig. 5.

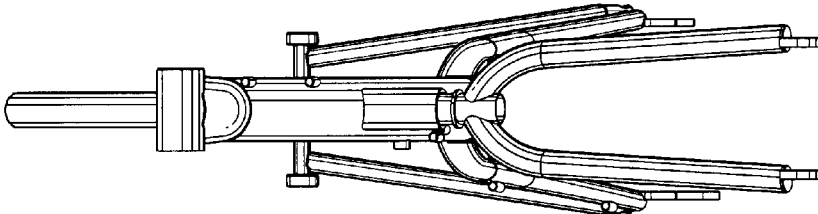

Fig. 4.

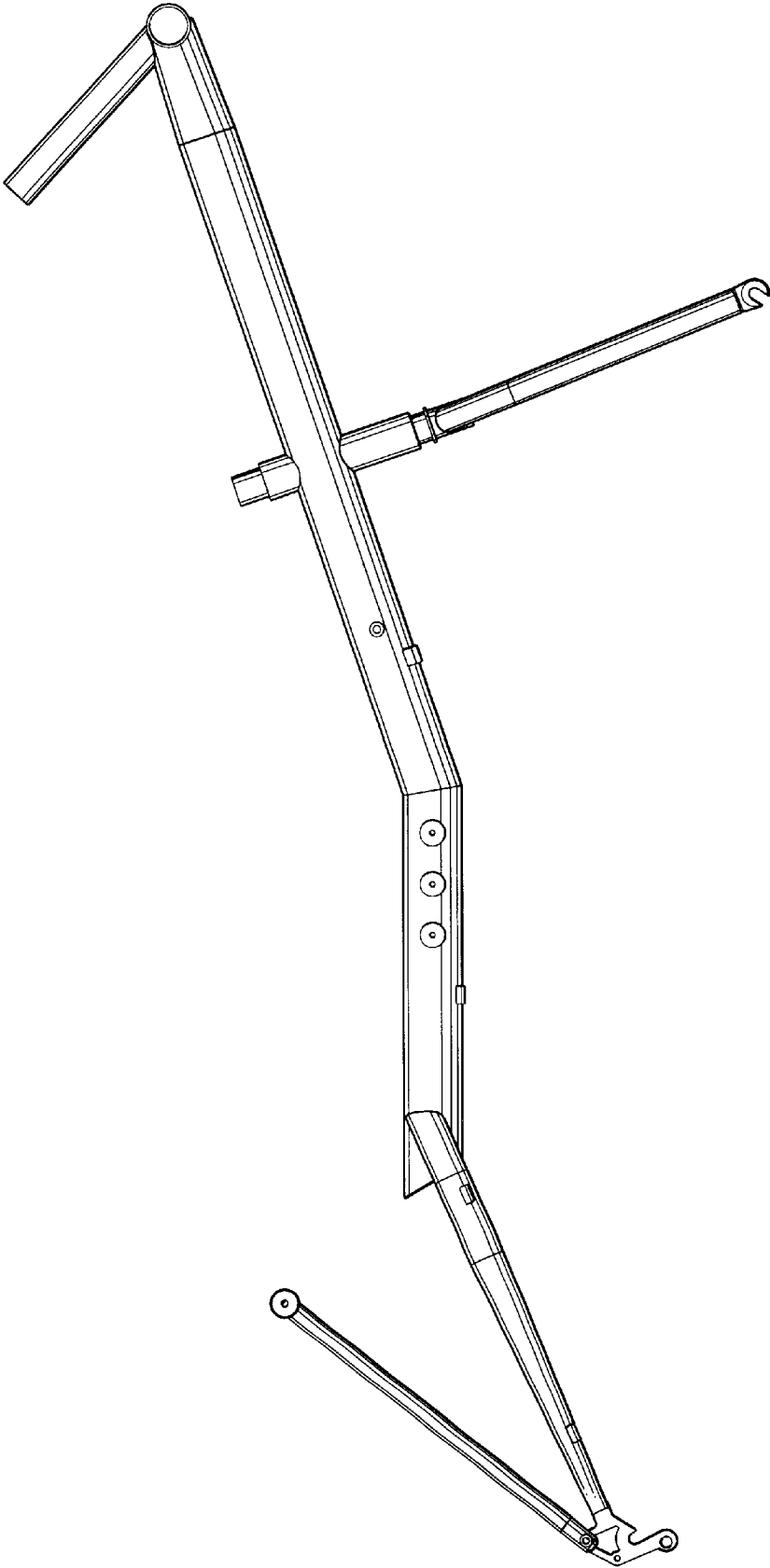

Fig. 6.

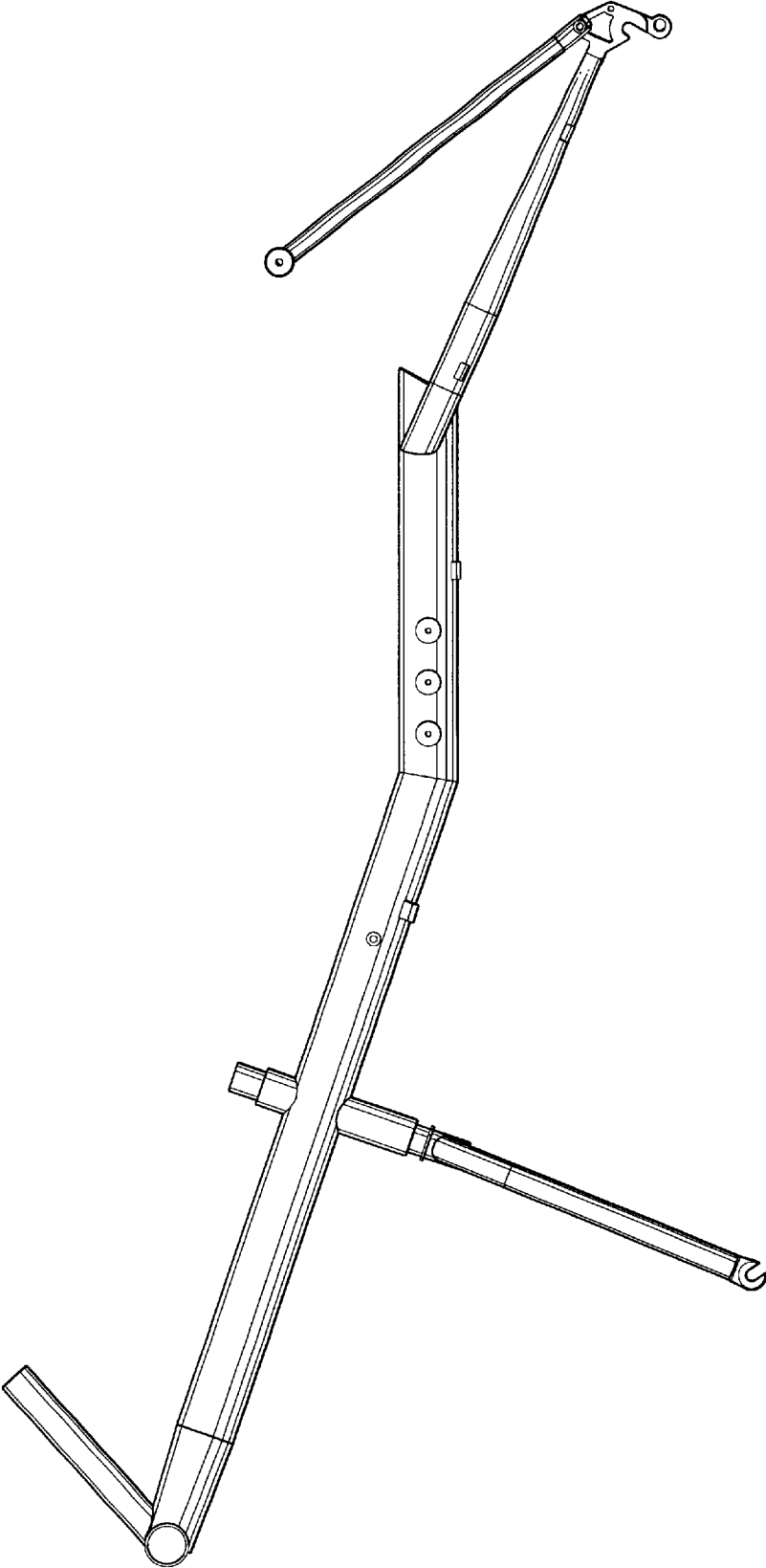

Fig. 7.