



US00D643785S

(12) **United States Design Patent**
Kyu

(10) **Patent No.:** **US D643,785 S**

(45) **Date of Patent:** **** Aug. 23, 2011**

(54) **FRAME FOR A BICYCLE**

(74) *Attorney, Agent, or Firm* — McDermott Will & Emery LLP

(75) **Inventor:** **Song Joon Kyu**, Kyungki-Do (KR)

(73) **Assignee:** **Mando Corporation**, Gyeonggi-do (KR)

(57) **CLAIM**
The ornamental design for a frame for a bicycle, as shown and described.

(**) **Term:** **14 Years**

(21) **Appl. No.:** **29/379,863**

(22) **Filed:** **Nov. 24, 2010**

(51) **LOC (9) Cl.** **12-11**

(52) **U.S. Cl.** **D12/111**

(58) **Field of Classification Search** D12/111,
D12/117, 119; 280/274–280, 281.1, 283–288,
280/288.1–288.4

See application file for complete search history.

DESCRIPTION

FIG. 1 is a front/right-side/top perspective view of a frame for a bicycle showing the new design;
FIG. 2 is a front-side elevational view thereof;
FIG. 3 is a rear-side elevational view thereof;
FIG. 4 is a left-side elevational view thereof;
FIG. 5 is a right-side elevational view thereof;
FIG. 6 is a top-side elevational view thereof; and
FIG. 7 is a bottom-side elevational view thereof.
FIG. 8 is a front/right-side/top perspective view of the frame for a bicycle in a folded configuration;
FIG. 9 is a front-side elevational view thereof;
FIG. 10 is a rear-side elevational view thereof;
FIG. 11 is a left-side elevational view thereof;
FIG. 12 is a right-side elevational view thereof;
FIG. 13 is a top-side elevational view thereof;
FIG. 14 is a bottom-side elevational view thereof; and,
FIG. 15 illustrates is a front/right-side/top perspective view of the claimed frame for a bicycle, with environmental structure illustrated in broken lines that forms no part of the claimed design.

(56) **References Cited**

U.S. PATENT DOCUMENTS

6,032,971	A *	3/2000	Herder	280/278
6,267,401	B1 *	7/2001	De Jong	280/287
6,688,625	B1 *	2/2004	Schreuder et al.	280/260
D487,234	S *	3/2004	Chen et al.	D12/111
6,764,090	B1 *	7/2004	Pan	280/278
D494,508	S *	8/2004	Liu	D12/111
D497,574	S *	10/2004	Yamabe	D12/111
D547,702	S *	7/2007	Tabuchi et al.	D12/111

* cited by examiner

Primary Examiner — Susan M Lee
Assistant Examiner — Linda Brooks

1 Claim, 15 Drawing Sheets

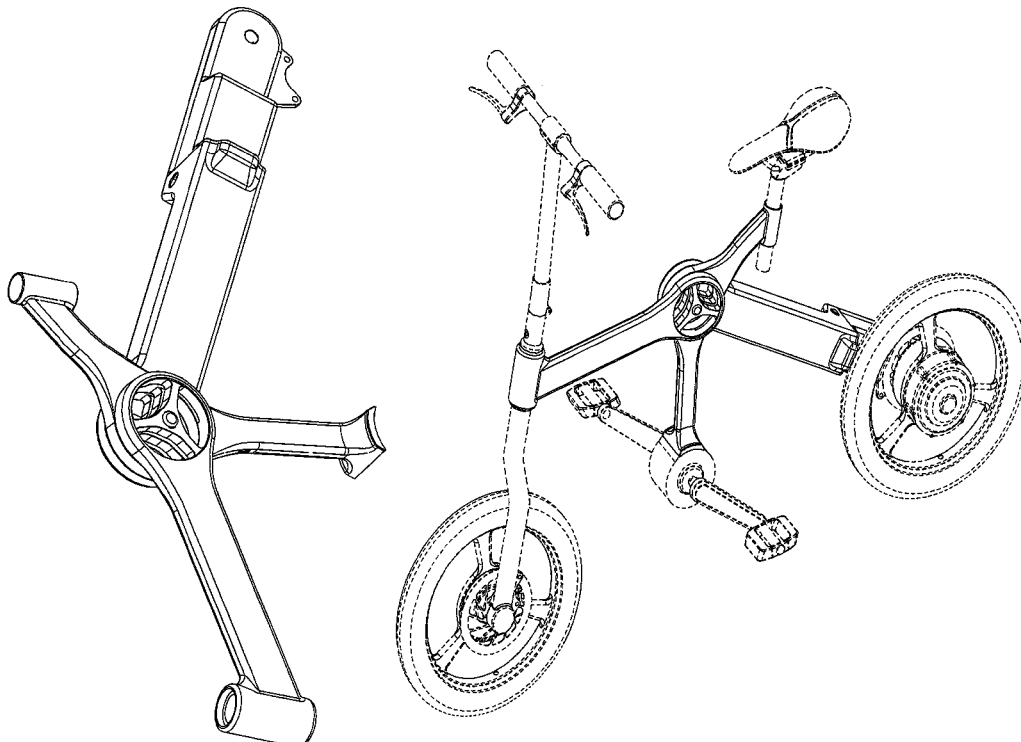

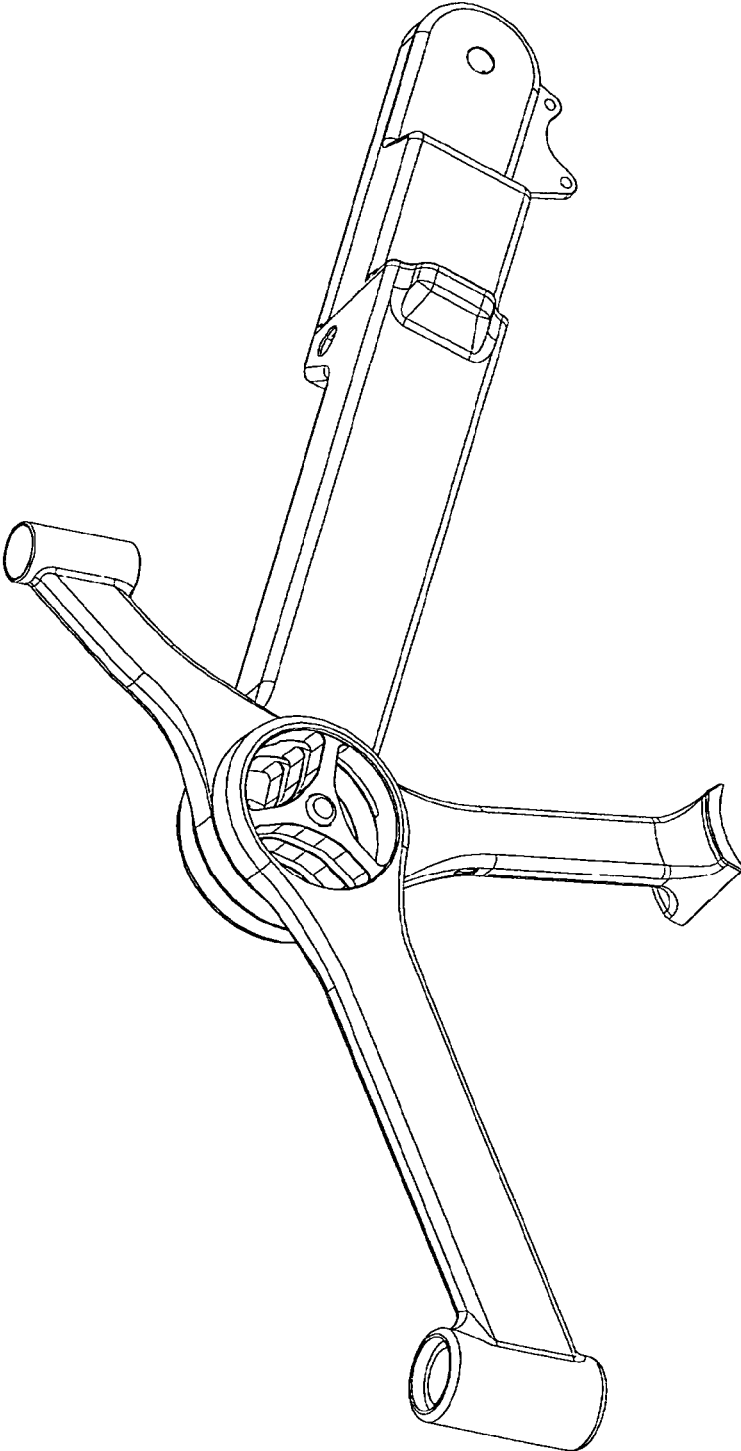

FIG. 1

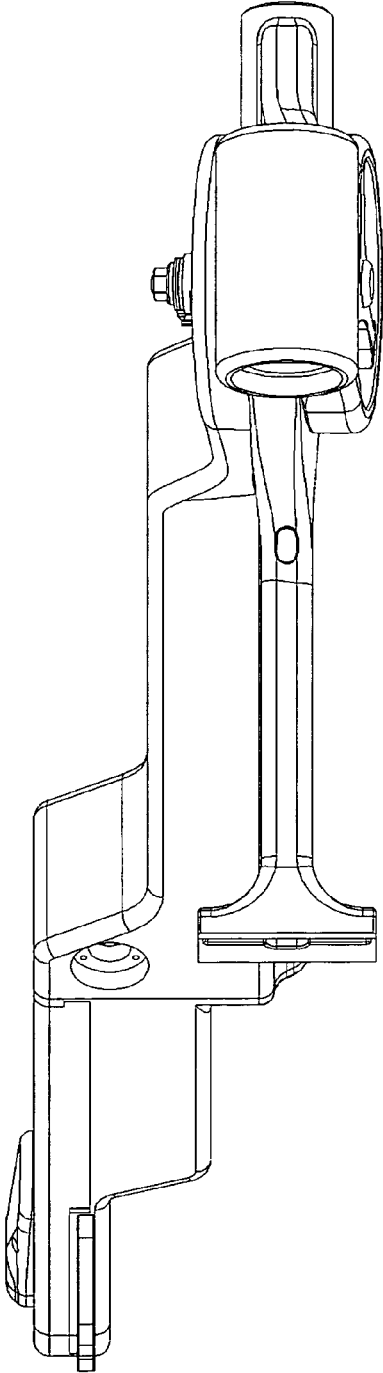

FIG. 2

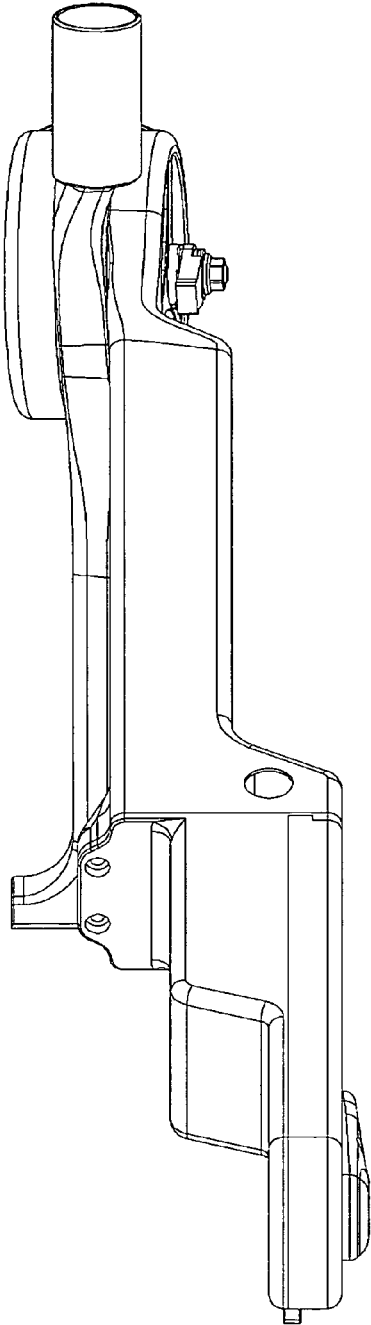

FIG. 3

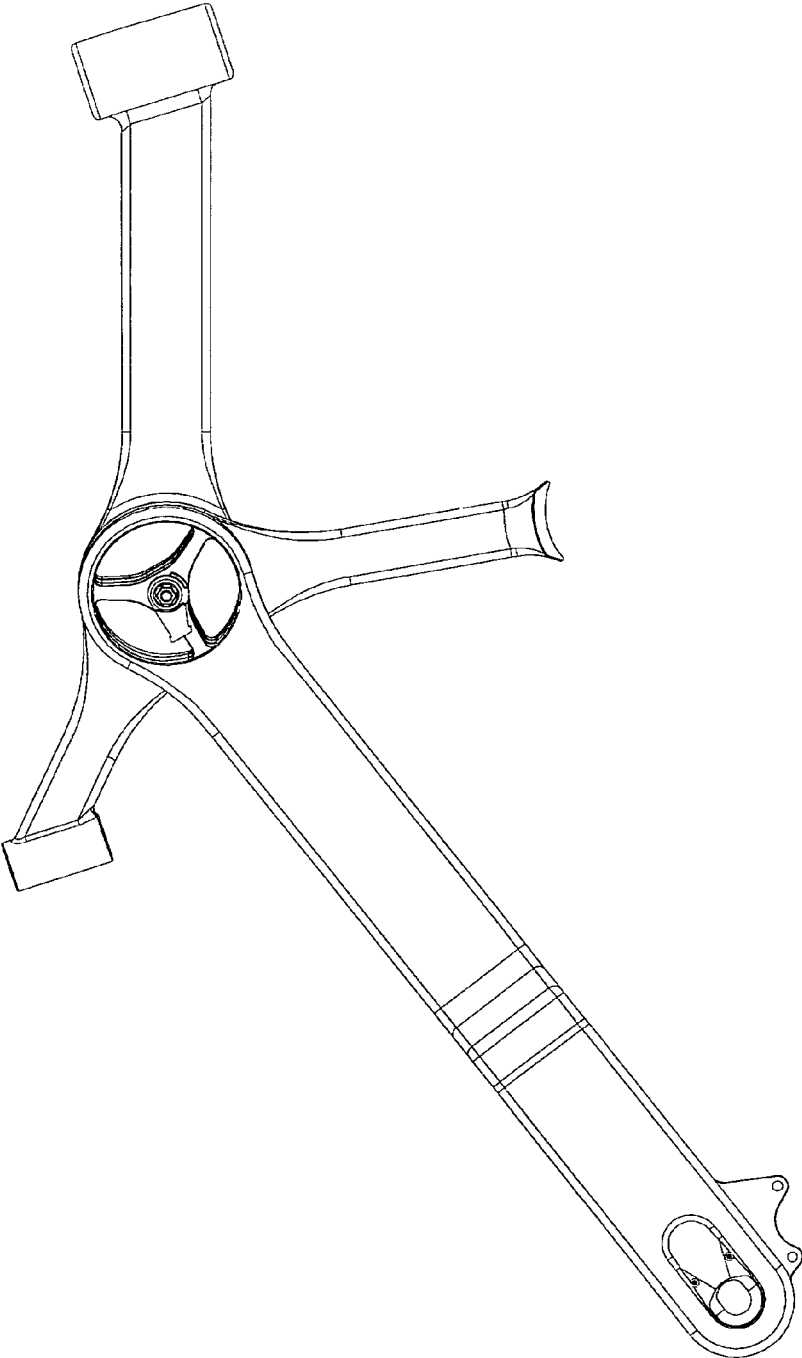

FIG. 4

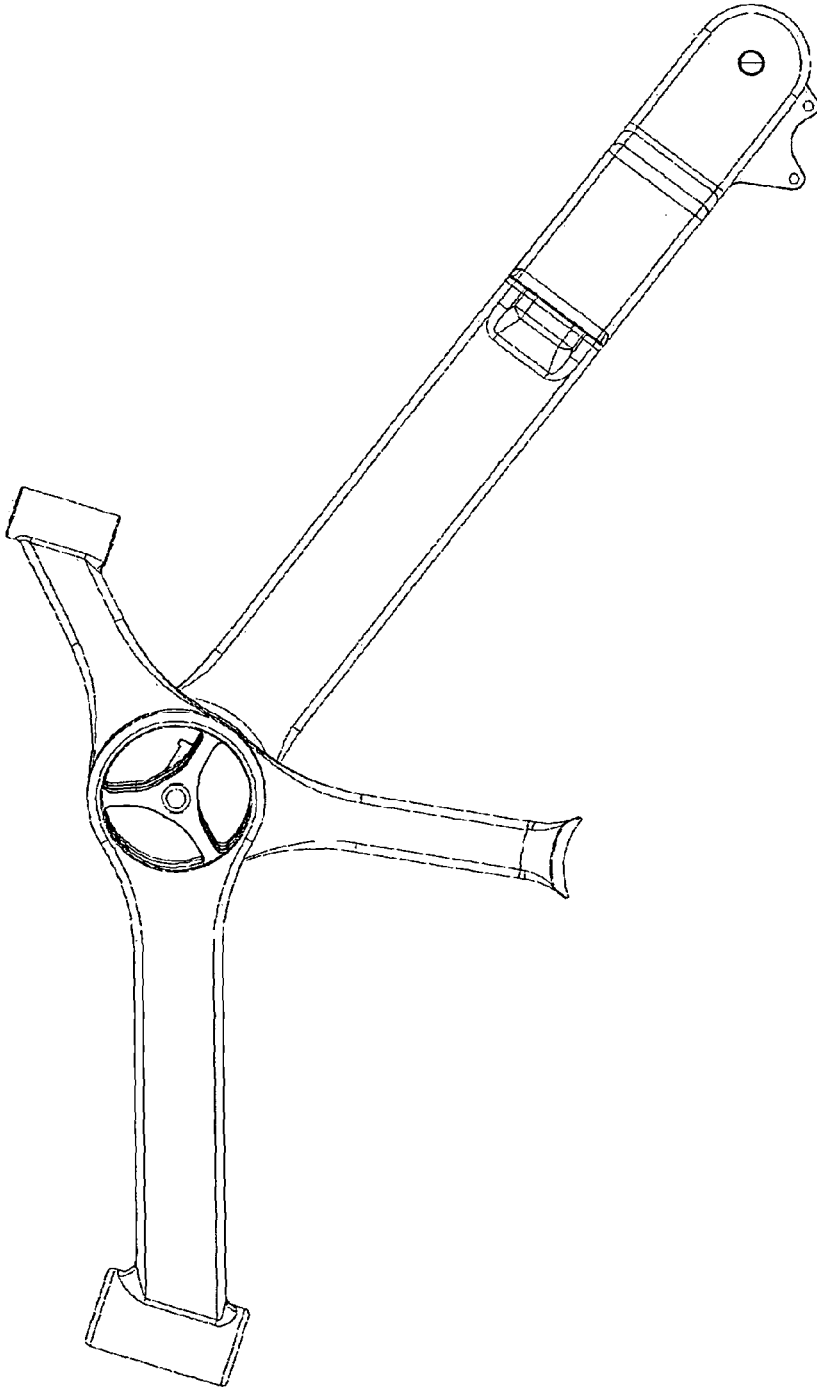

FIG. 5

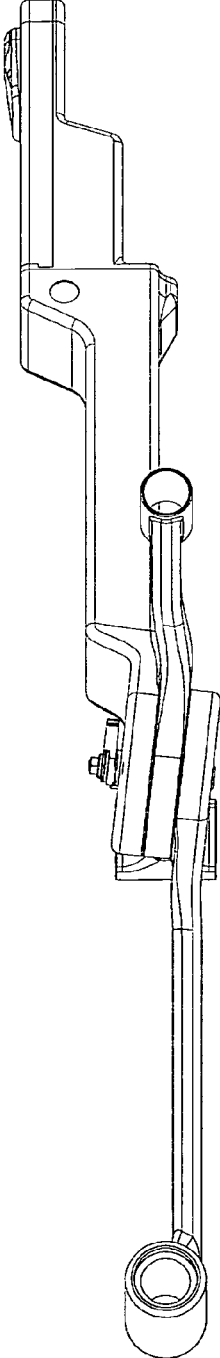

FIG. 6

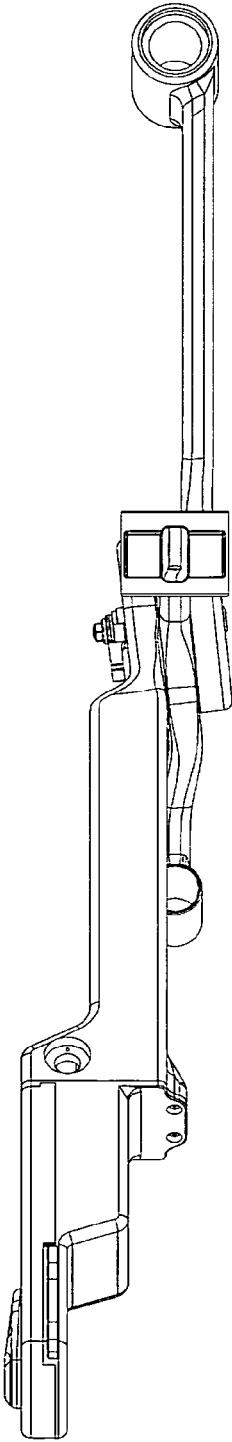

FIG. 7

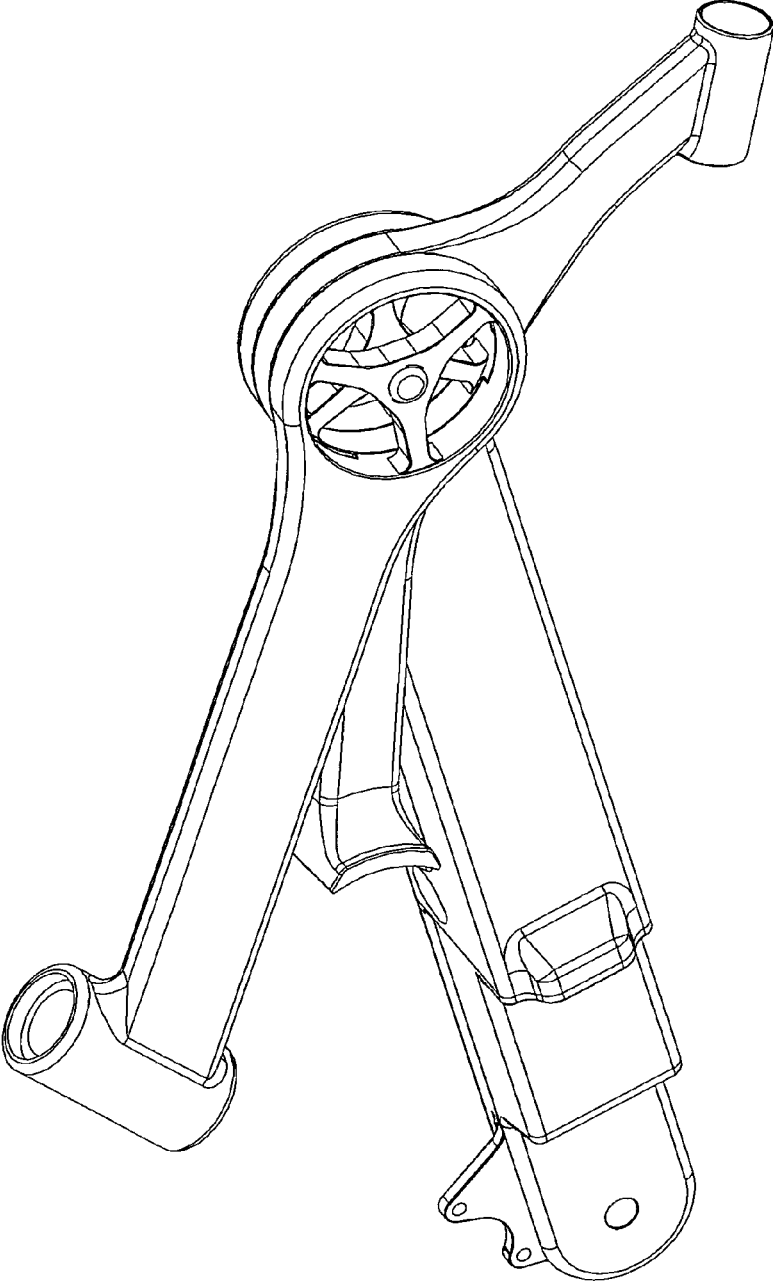

FIG. 8

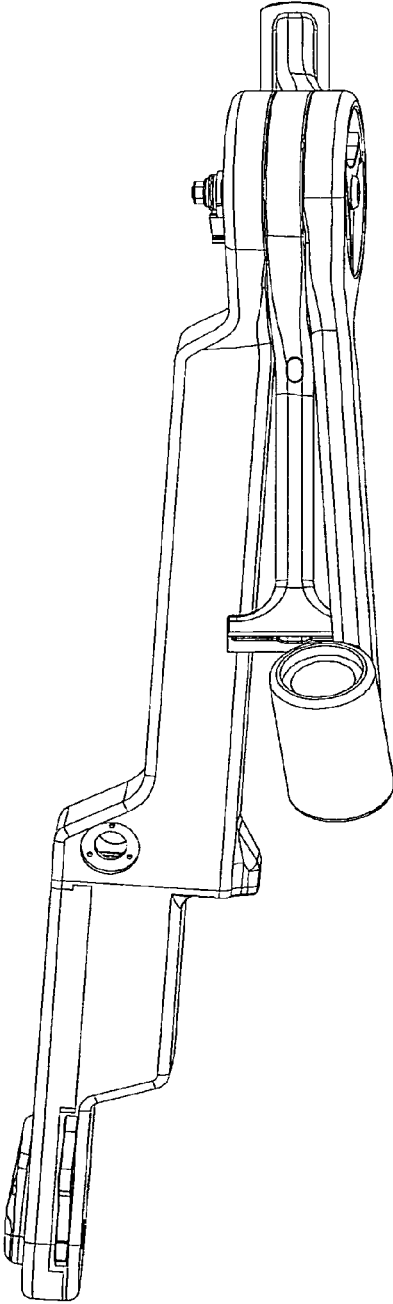

FIG. 9

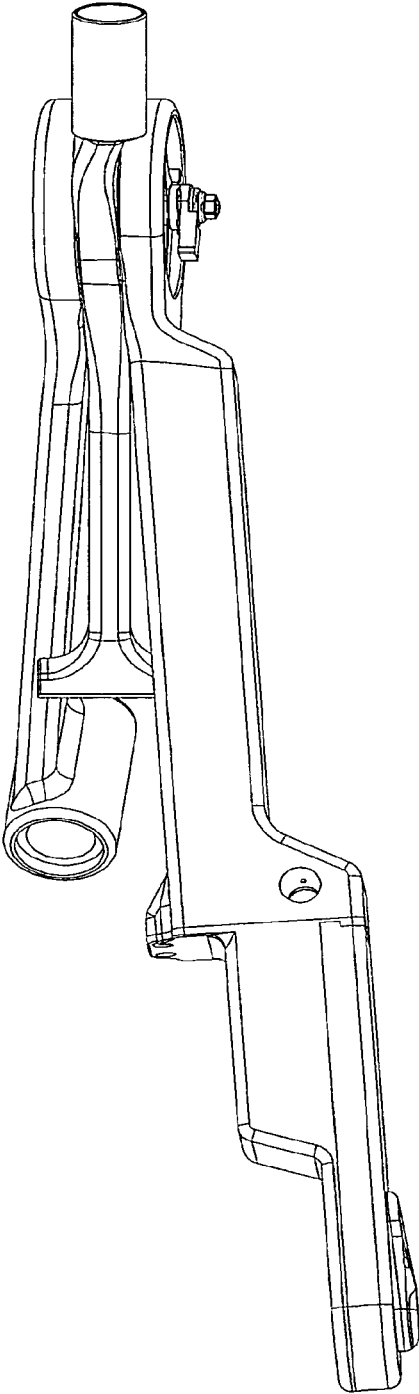

FIG. 10

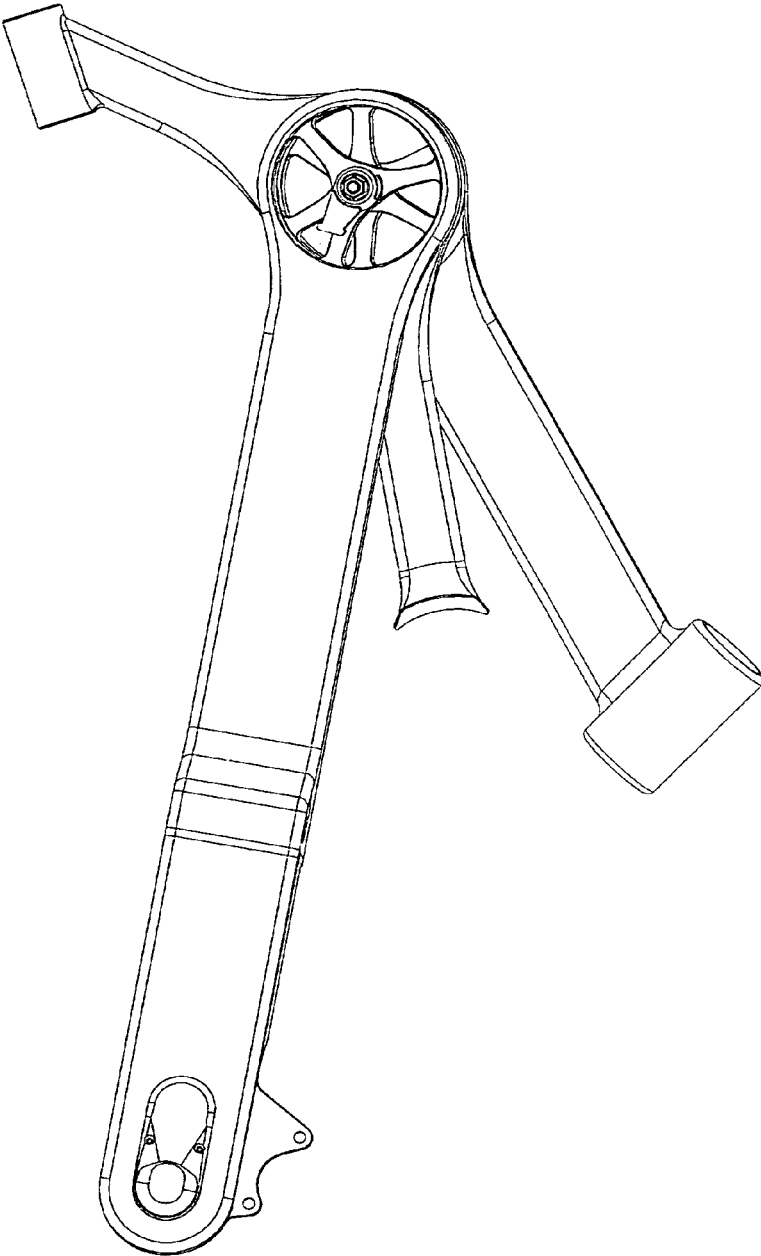

FIG. 11

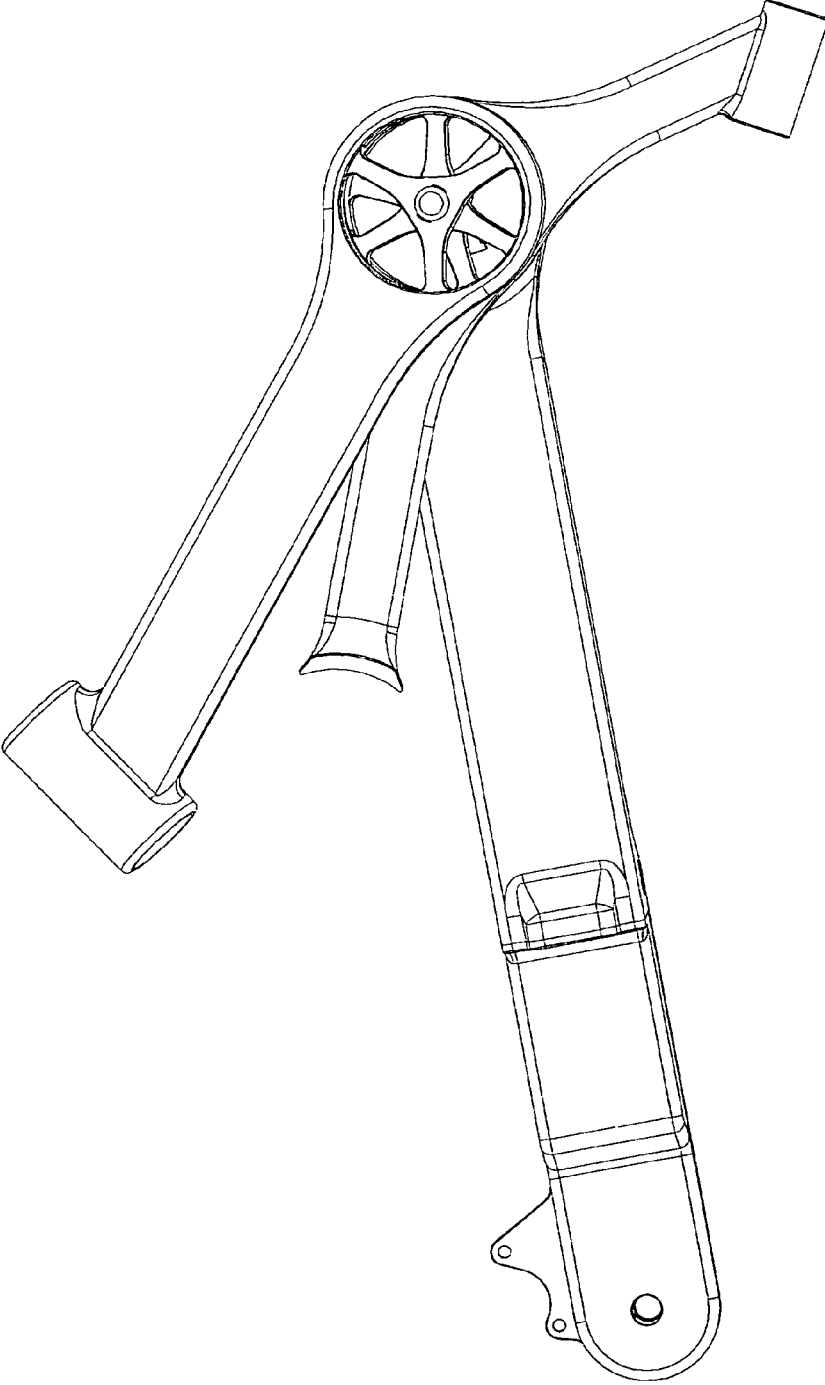

FIG. 12

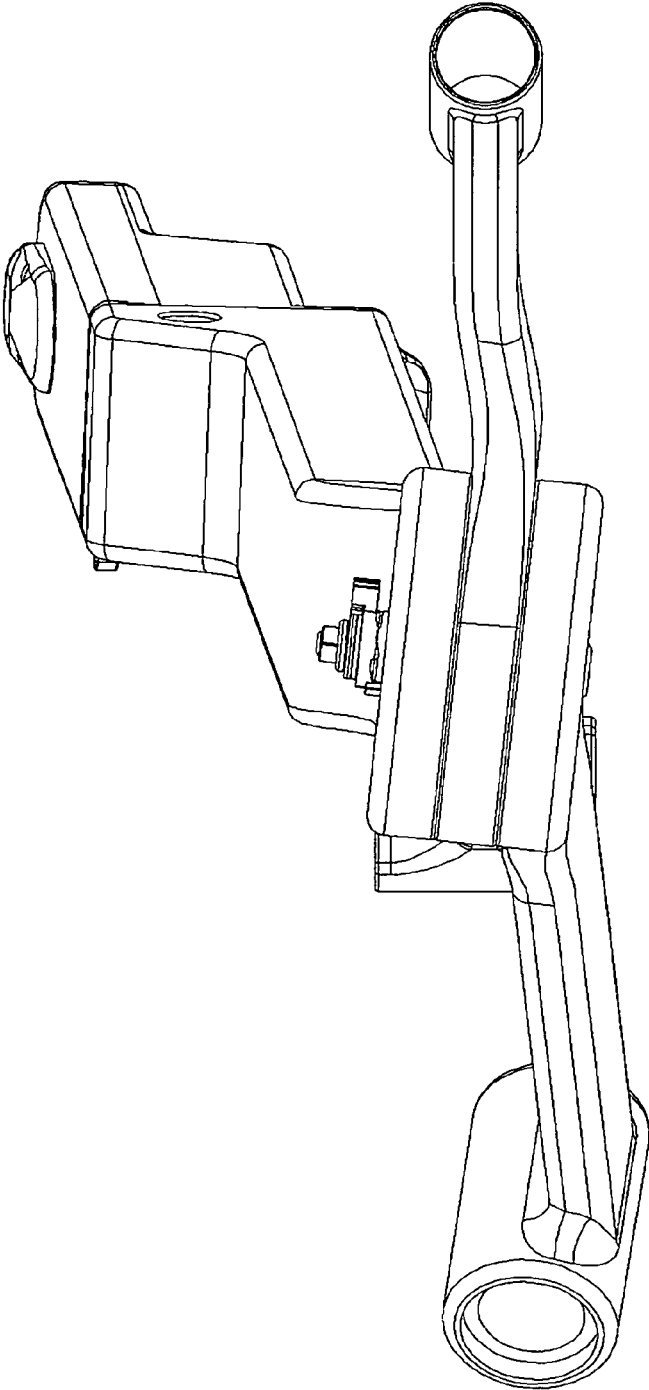

FIG. 13

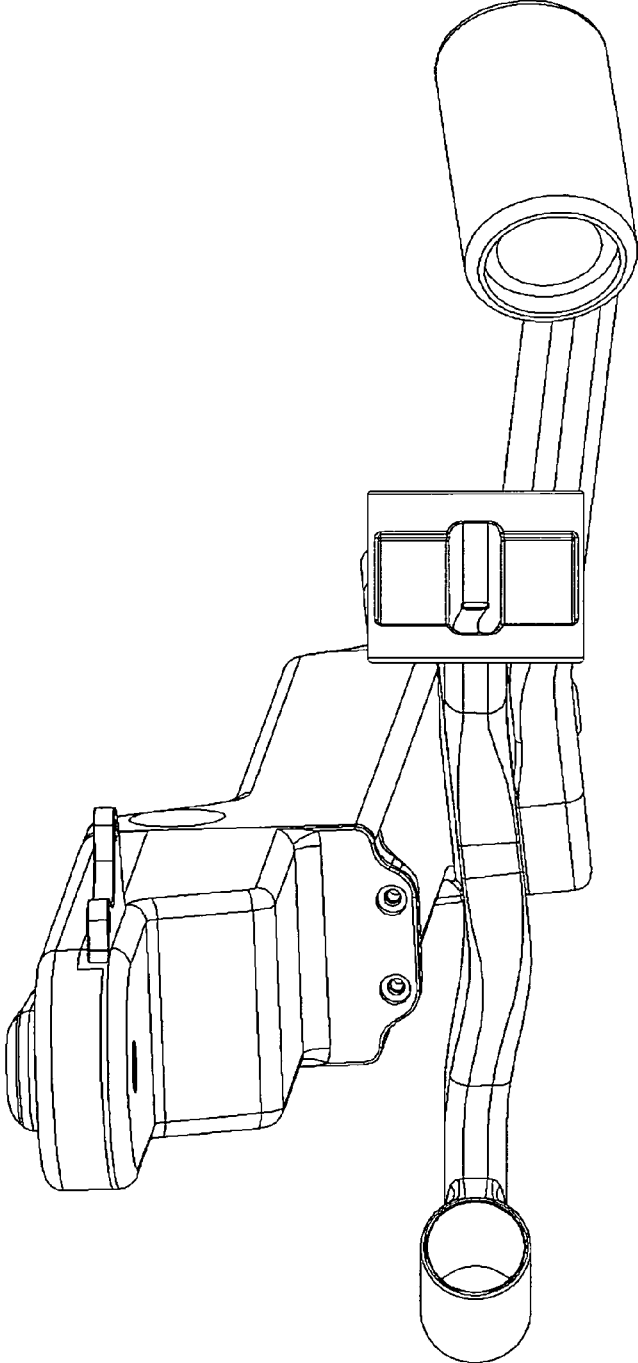

FIG. 14

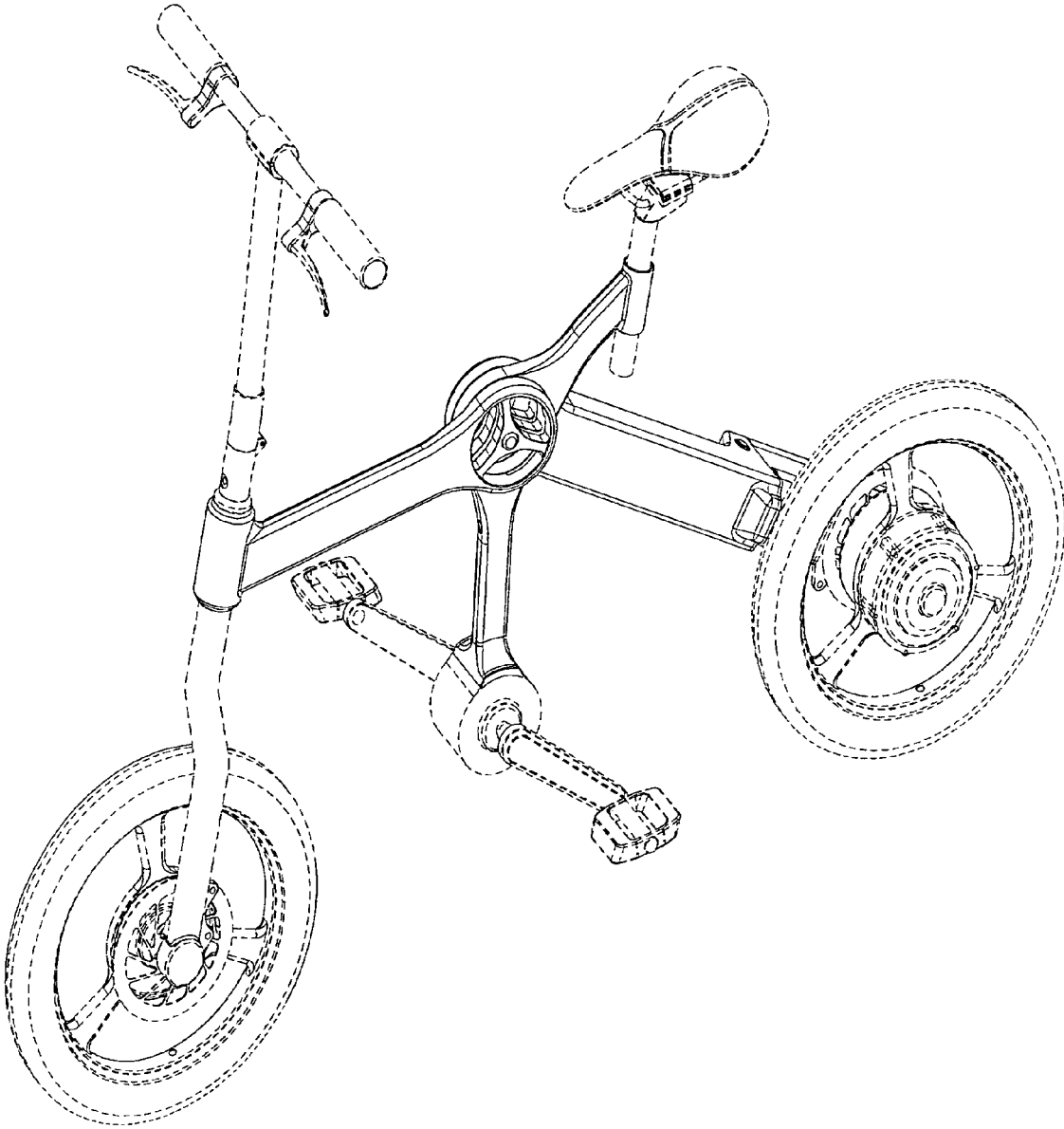

FIG. 15