



US00D774983S

(12) **United States Design Patent**  
**Lam**

(10) **Patent No.:** **US D774,983 S**

(45) **Date of Patent:** **\*\* Dec. 27, 2016**

(54) **BICYCLE FRAME INSERT**

D380,510 S \* 7/1997 Porkka ..... D21/683  
D381,711 S \* 7/1997 Englert ..... D21/572  
D396,434 S \* 7/1998 Tseng ..... D12/111

(Continued)

(71) Applicant: **Trek Bicycle Corporation**, Waterloo,  
WI (US)

(72) Inventor: **Vi Lam**, South Elgin, IL (US)

(73) Assignee: **Trek Bicycle Corporation**, Waterloo,  
WI (US)

(\*\*) Term: **14 Years**

(21) Appl. No.: **29/491,772**

(22) Filed: **May 23, 2014**

(51) **LOC (10) Cl.** ..... **12-11**

(52) **U.S. Cl.** ..... **D12/117**  
USPC .....

(58) **Field of Classification Search**

USPC ..... D12/111, 114, 117; 280/274–280, 281.1,  
280/283–288, 288.1–288.4

CPC ..... B62K 3/00; B62K 3/005; B62K 9/00;  
B62K 19/00; B62K 19/02; B62K 19/04;  
B62K 19/06; B62K 19/16

See application file for complete search history.

(56) **References Cited**

**U.S. PATENT DOCUMENTS**

D245,412 S \* 8/1977 Ray ..... D12/126  
D246,170 S \* 10/1977 Powers ..... D12/111  
D246,779 S \* 12/1977 Cognata ..... D12/126  
D250,329 S \* 11/1978 Breen ..... D12/126  
D326,247 S \* 5/1992 Hess ..... D12/111  
D342,221 S \* 12/1993 De Silva ..... D12/114  
D343,599 S \* 1/1994 Camfield et al. .... D12/11  
D345,325 S \* 3/1994 Camfield et al. .... D12/117  
D359,467 S \* 6/1995 Hsieh ..... D12/117  
D374,848 S \* 10/1996 Liles et al. .... D12/114  
D376,123 S \* 12/1996 Camfield ..... D12/114  
D376,775 S \* 12/1996 Fang ..... D12/117

**OTHER PUBLICATIONS**

“Trek Jet 16 inch Coaster brake BMX kids bicycle—Red/Black.”  
JollyMap., Sep. 28, 2014 [online], [retrieved on Apr. 17, 2015].  
Retrieved from the Internet <URL: <http://www.jollymap.com/en/kids-bikes/422-trek-jet-16-inch-coaster-brake-bmx-kids-bicycle-red-black.html>>.\*

*Primary Examiner* — Darlington Ly

(57) **CLAIM**

The ornamental design for a bicycle frame insert, as shown  
and described.

**DESCRIPTION**

This application is related to U.S. Design patent application  
Ser. Nos. 29/491,777, titled “Saddle with Grips,” and  
29/491,778, titled “Bicycle with Integrated Accessories,”  
both of which are concurrently filed.

FIG. 1 is a top view of a frame insert showing my new  
design;

FIG. 2 is a bottom view thereof;

FIG. 3 is a left view thereof;

FIG. 4 is right view thereof;

FIG. 5 is a rear view thereof;

FIG. 6 is a front view thereof;

FIG. 7 is a bottom, front, and left-side perspective view  
thereof;

FIG. 8 is a top, rear and left-side perspective view thereof;

FIG. 9 is a top, front and right-side perspective view thereof;  
and,

FIG. 10 is a bottom, rear and right-side perspective view  
thereof.

The broken lines in the drawings illustrate portions of the  
bicycle frame insert that forms no part of the claimed design.

**1 Claim, 5 Drawing Sheets**

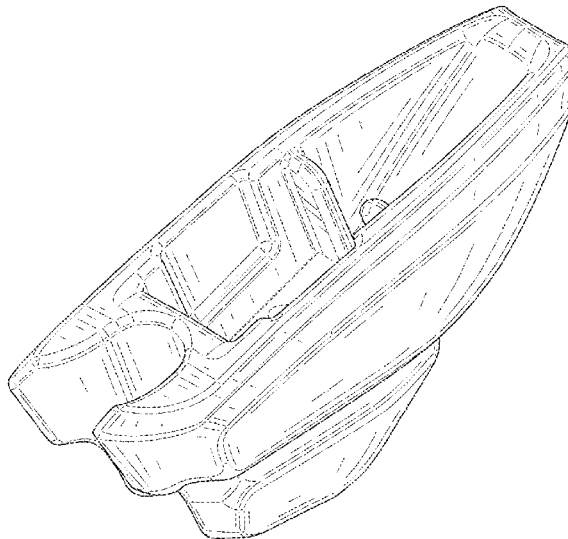

(56)

**References Cited**

U.S. PATENT DOCUMENTS

|          |   |   |         |                 |       |         |
|----------|---|---|---------|-----------------|-------|---------|
| D409,528 | S | * | 5/1999  | Huang           | ..... | D12/111 |
| D421,937 | S | * | 3/2000  | Huang           | ..... | D12/111 |
| D447,094 | S | * | 8/2001  | Conte           | ..... | D12/114 |
| D466,471 | S | * | 12/2002 | Chen            | ..... | D12/407 |
| D550,592 | S | * | 9/2007  | Wu              | ..... | D12/114 |
| D626,493 | S | * | 11/2010 | Dallaire et al. | ..... | D12/407 |
| D685,687 | S | * | 7/2013  | Richter         | ..... | D12/114 |
| D722,540 | S | * | 2/2015  | Brunner et al.  | ..... | D12/114 |

\* cited by examiner

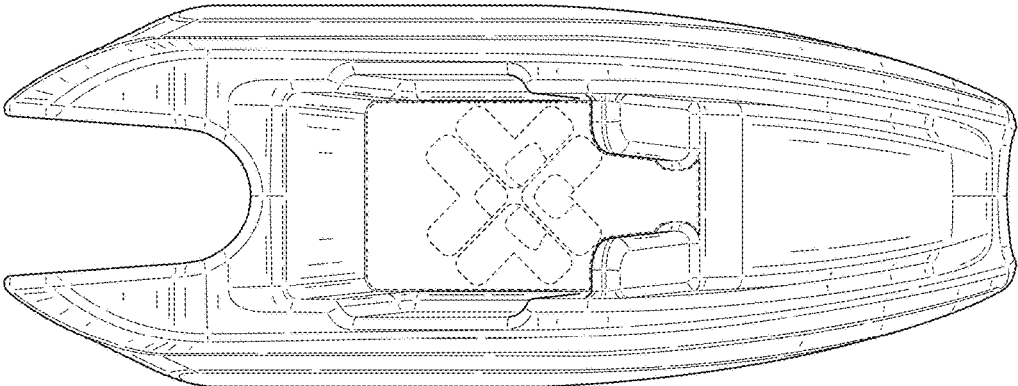

FIG. 1

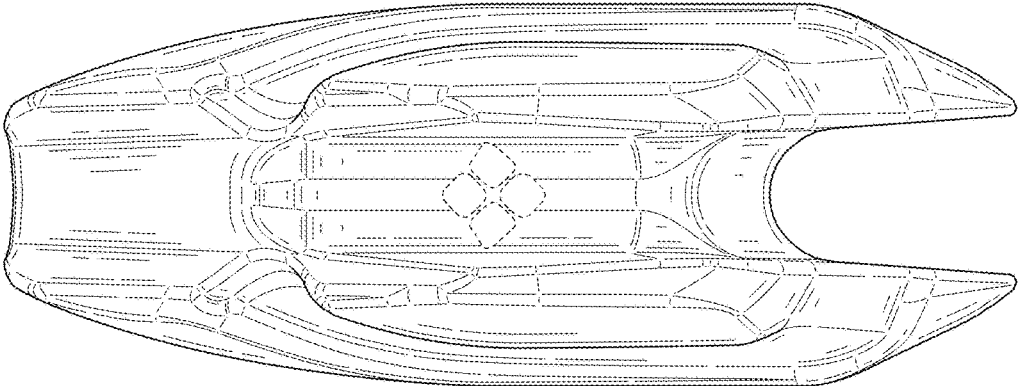

FIG. 2

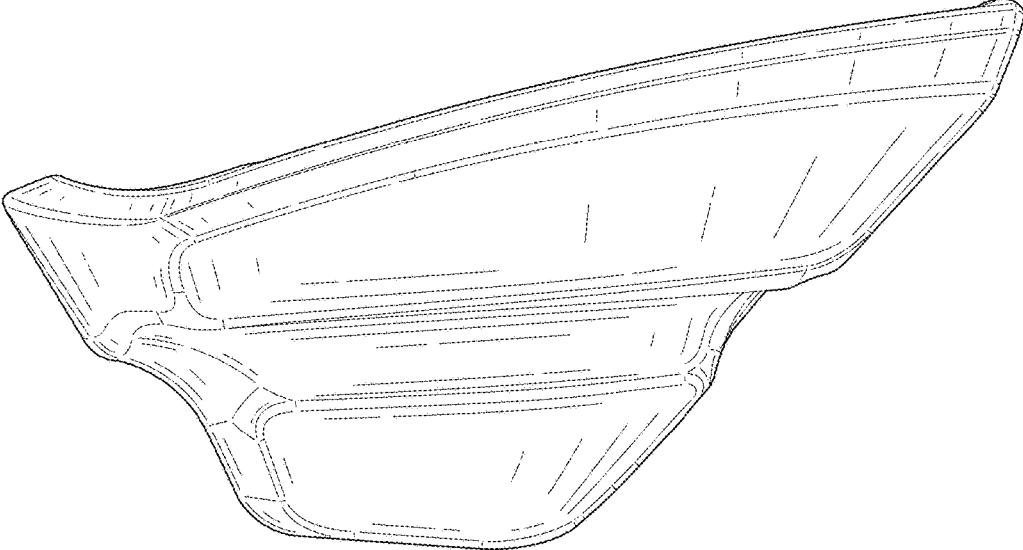

FIG. 3

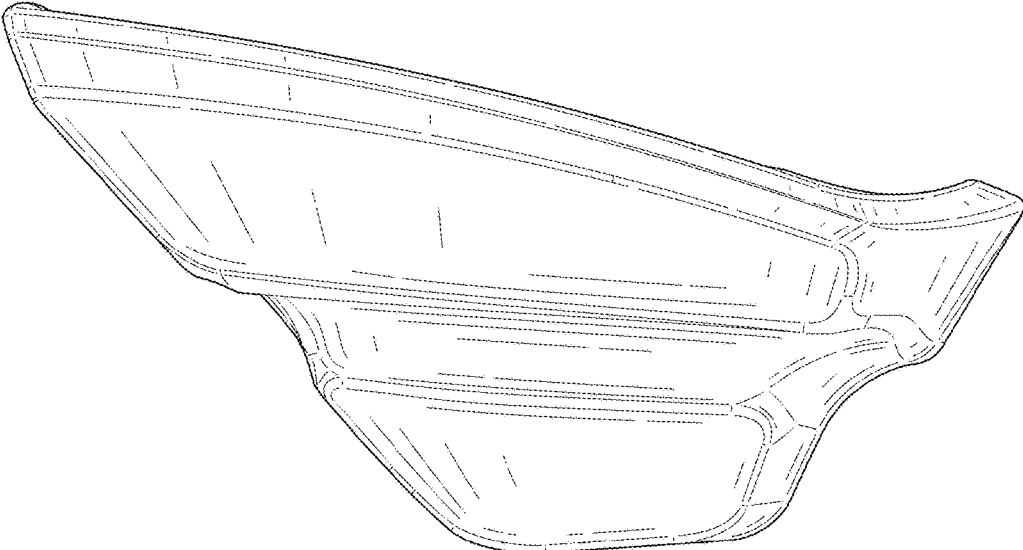

FIG. 4

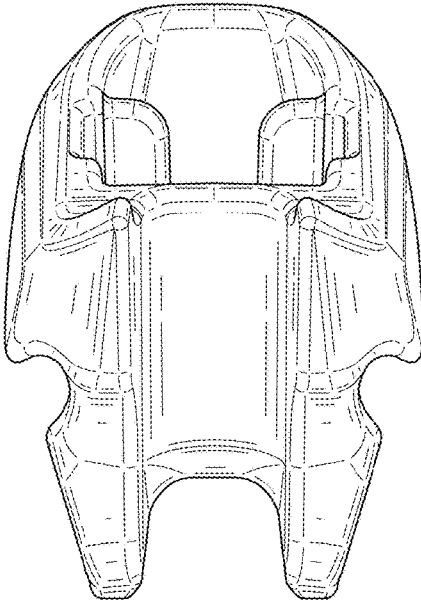

FIG. 5

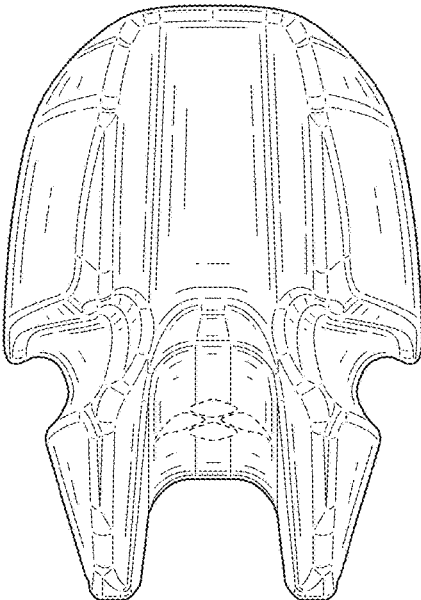

FIG. 6

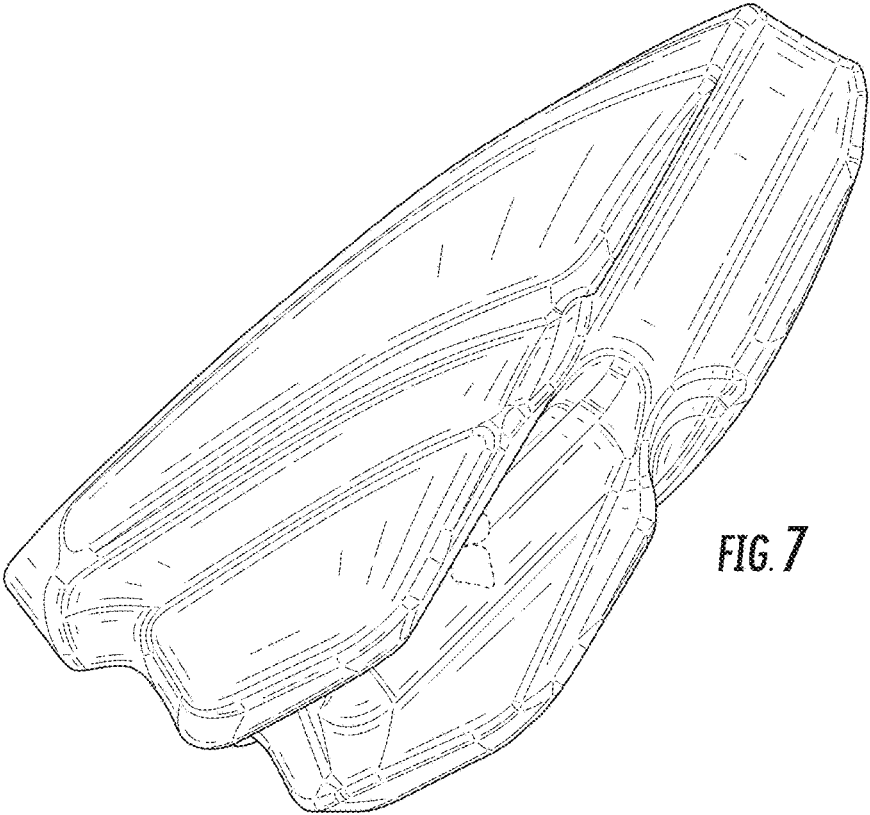

FIG. 7

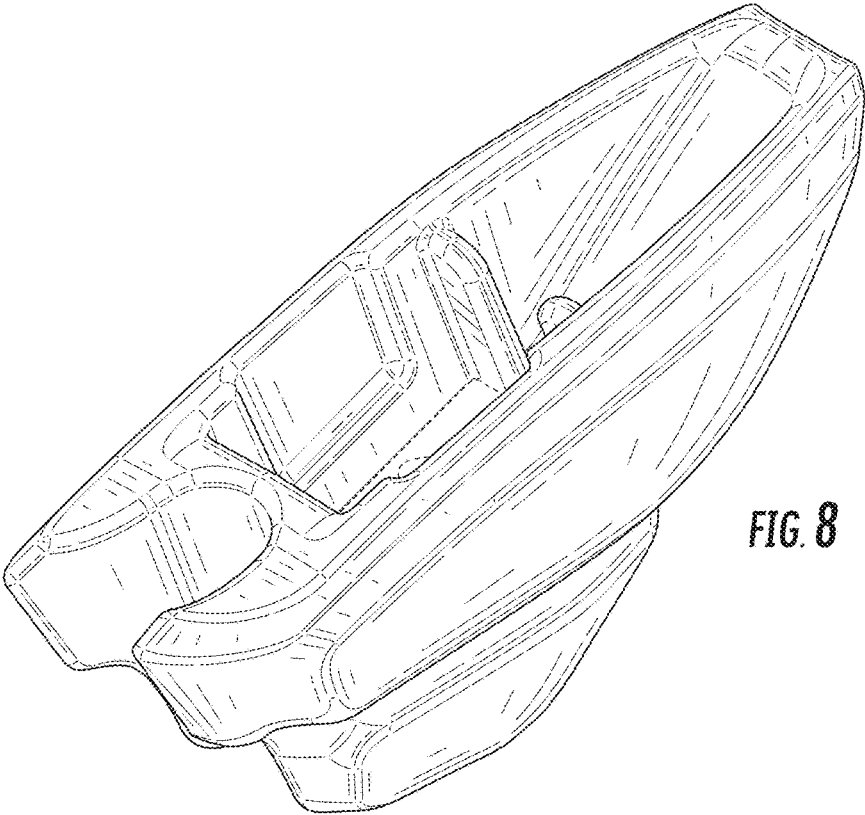

FIG. 8

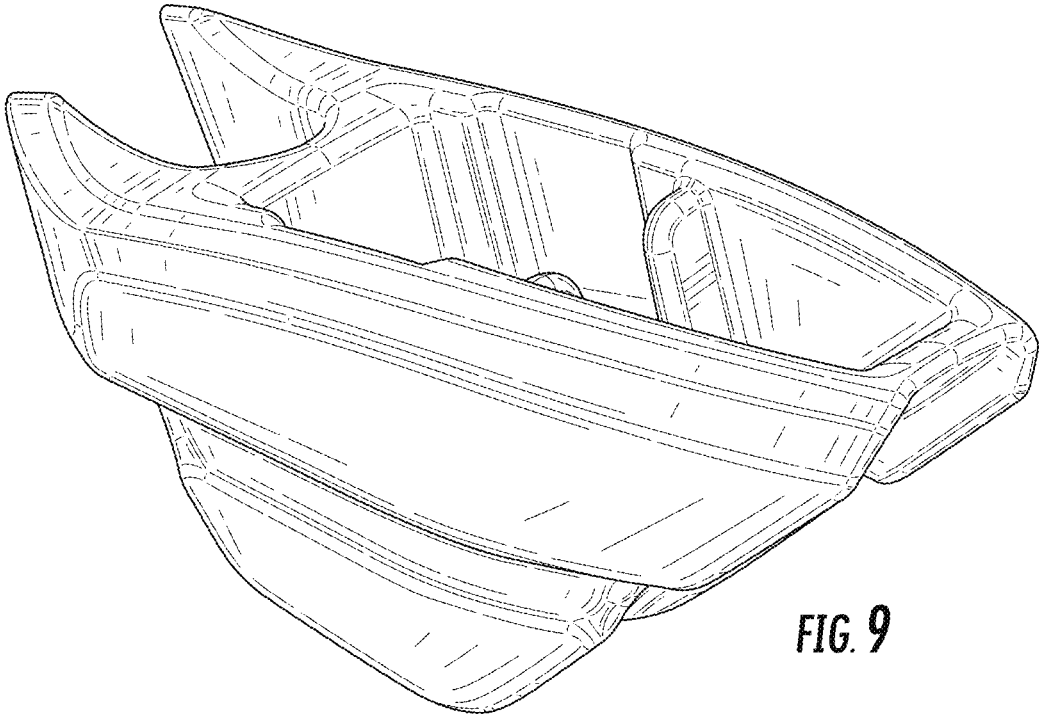

FIG. 9

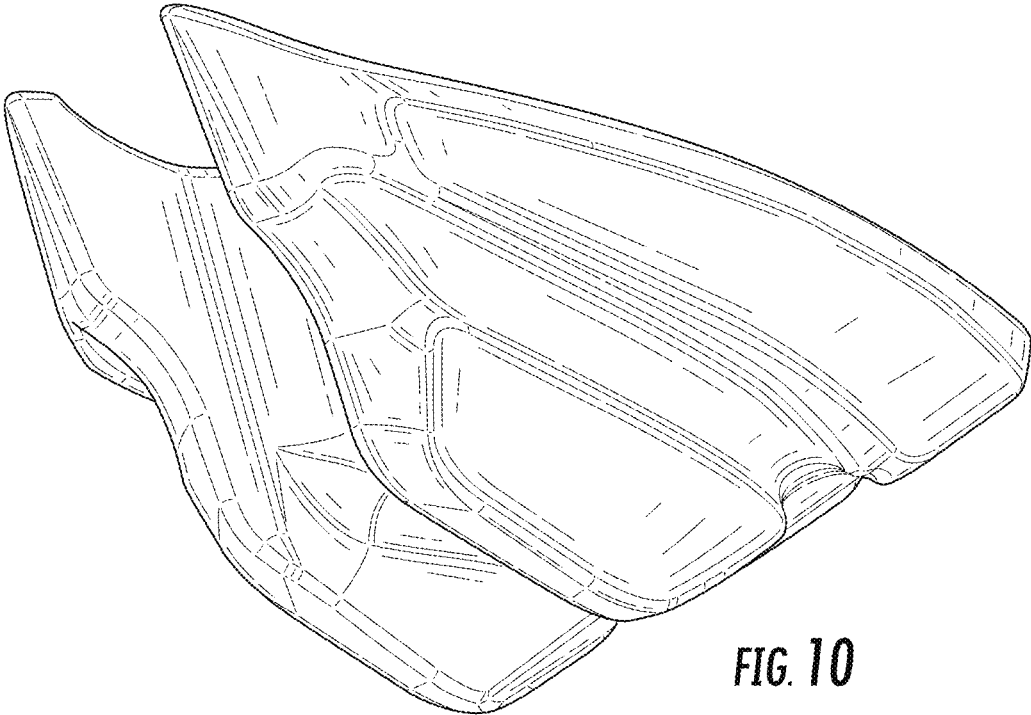

FIG. 10