



US010207393B2

(12) **United States Patent**
Wu

(10) **Patent No.:** **US 10,207,393 B2**
(45) **Date of Patent:** ***Feb. 19, 2019**

(54) **LOCKING PLIERS**
(71) Applicant: **Ming Chieh Wu**, Taichung (TW)
(72) Inventor: **Ming Chieh Wu**, Taichung (TW)
(*) Notice: Subject to any disclaimer, the term of this patent is extended or adjusted under 35 U.S.C. 154(b) by 683 days.

This patent is subject to a terminal disclaimer.

3,262,343 A * 7/1966 Weller B25B 7/123 81/370
3,710,658 A * 1/1973 Wilson B25B 7/123 81/367
3,894,451 A 7/1975 Putsch
4,499,797 A 2/1985 Wilson
4,989,479 A 2/1991 Anderson et al.
5,056,385 A 10/1991 Petersen
(Continued)

(21) Appl. No.: **14/485,884**

FOREIGN PATENT DOCUMENTS
CN 101659014 3/2010
CN 101704227 5/2010
(Continued)

(22) Filed: **Sep. 15, 2014**

(65) **Prior Publication Data**
US 2015/0000477 A1 Jan. 1, 2015

OTHER PUBLICATIONS

European Search Report from European Application 12170983.6-1251, dated Oct. 22, 2012, 7 pages.

Related U.S. Application Data

(63) Continuation-in-part of application No. 13/469,469, filed on May 11, 2012, now Pat. No. 8,950,299.

Primary Examiner — Hadi Shakeri
(74) *Attorney, Agent, or Firm* — Alan D. Kamrath; Kamrath IP Lawfirm, P.A.

(30) **Foreign Application Priority Data**

Jul. 12, 2011 (TW) 100124592 A

(57) **ABSTRACT**

(51) **Int. Cl.**
B25B 7/12 (2006.01)
(52) **U.S. Cl.**
CPC **B25B 7/123** (2013.01)
(58) **Field of Classification Search**
CPC B25B 7/123; B25B 7/14; B25B 7/02
USPC 81/379
See application file for complete search history.

A locking pliers includes a fixed handle. A fixed jaw is connected to the fixed handle. A movable jaw cooperates with the fixed jaw and includes movable and fixed pivoting regions. A movable handle is pivotally connected to the movable pivoting region. A movable pivot unit includes a pivot pin engaging with the fixed handle and the fixed pivoting region, and a pivot hole is disposed in one of the fixed handle and the fixed pivoting region and configured and dimensioned to loosely receive the pivot pin. The pivot hole has a first diametrical size and the pivot pin has a second diametrical size not greater than 0.8 times the first diametrical size. A biasing member engages with the fixed handle and the movable jaw.

(56) **References Cited**

U.S. PATENT DOCUMENTS

1,867,912 A 7/1932 Evcy
2,519,630 A * 8/1950 Boyer B25B 7/10 81/373

13 Claims, 14 Drawing Sheets

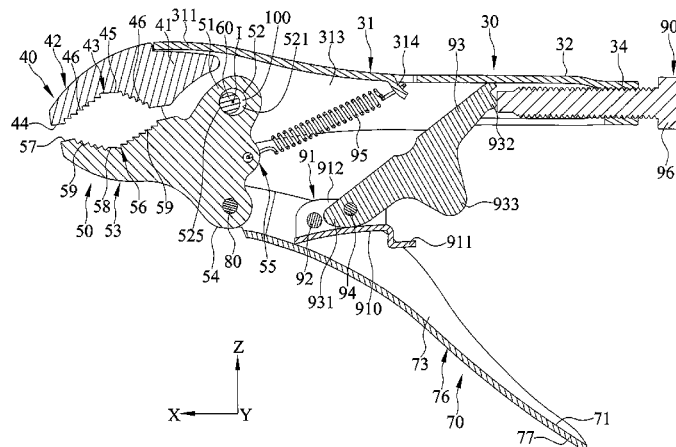

(56)

References Cited

U.S. PATENT DOCUMENTS

5,351,585	A	10/1994	Leseberg et al.	
5,456,144	A *	10/1995	Dahl	B25B 7/02 269/6
5,460,065	A	10/1995	Balmer	
5,520,040	A	5/1996	Pettersson	
6,393,951	B1	5/2002	Jansson	
6,626,070	B2	9/2003	Peperkom et al.	
6,862,962	B1 *	3/2005	Delbrugge, Jr.	B25B 7/10 81/355
7,143,671	B1	12/2006	Lai	
7,216,570	B2	5/2007	Seber et al.	
7,454,999	B2	11/2008	Wu	
7,472,632	B2	1/2009	Engvall et al.	
7,861,622	B2	1/2011	Chervenak et al.	
8,056,451	B2	11/2011	Chervenak et al.	
D651,060	S	12/2011	Chervenak et al.	
8,950,299	B2	2/2015	Wu	
2008/0196561	A1	8/2008	Wu	
2010/0018361	A1	1/2010	Chervenak et al.	
2014/0251093	A1	9/2014	Lai	

FOREIGN PATENT DOCUMENTS

EP	2149428	A1	2/2010
TW	M265172		5/2005
TW	M313580		6/2007
TW	200924914		6/2009
TW	M400919		4/2011

* cited by examiner

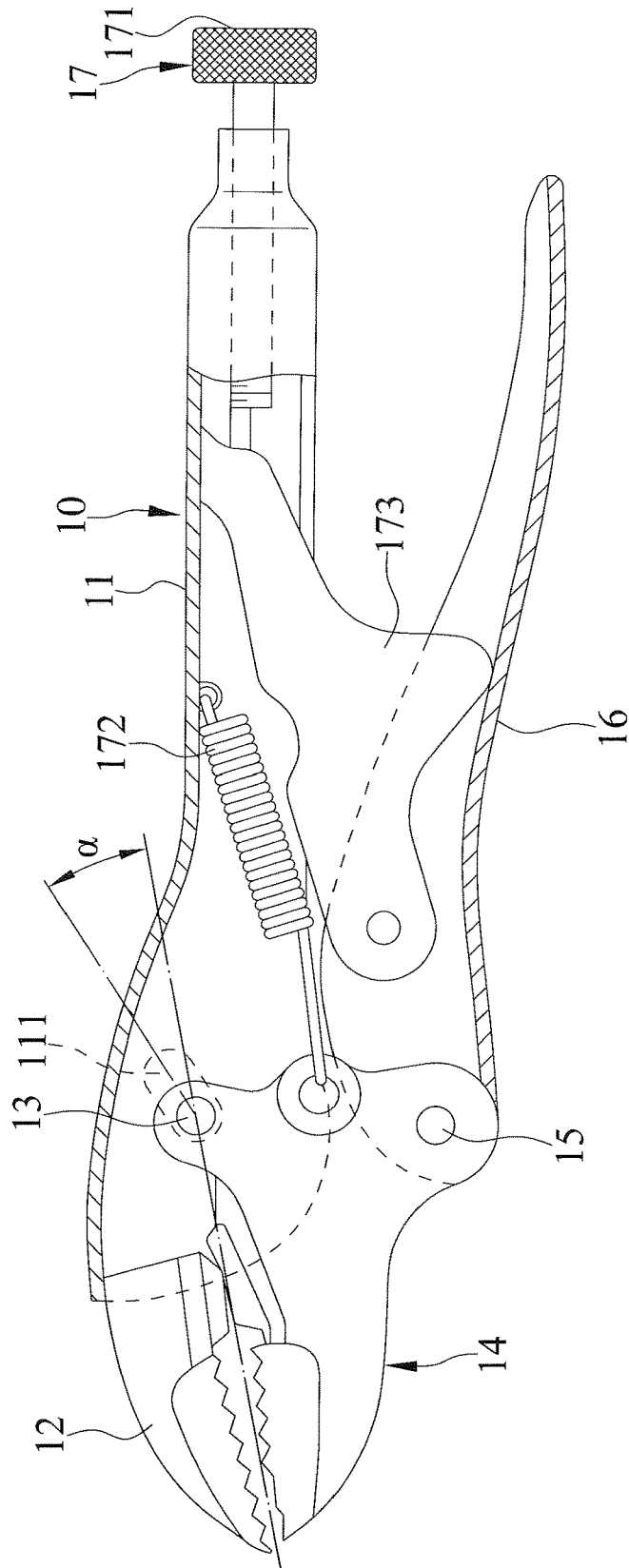

FIG. 1
PRIOR ART

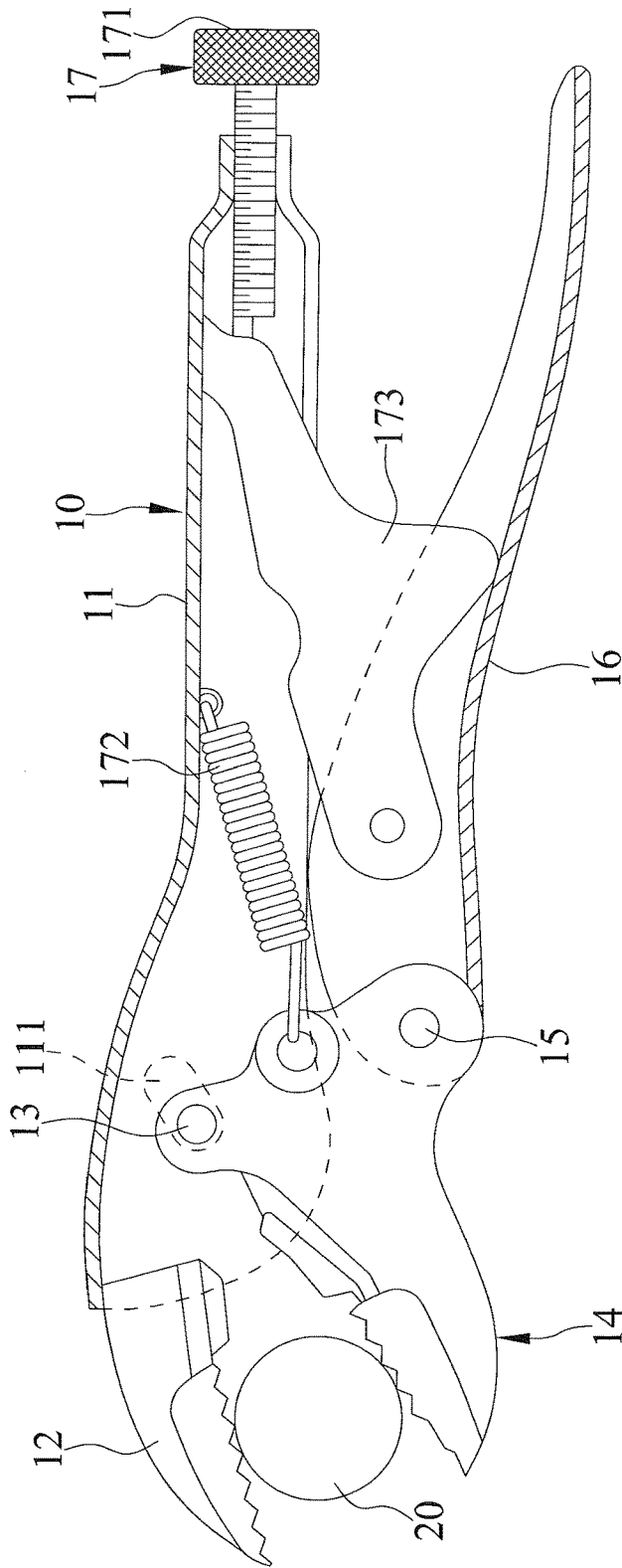

FIG. 2
PRIOR ART

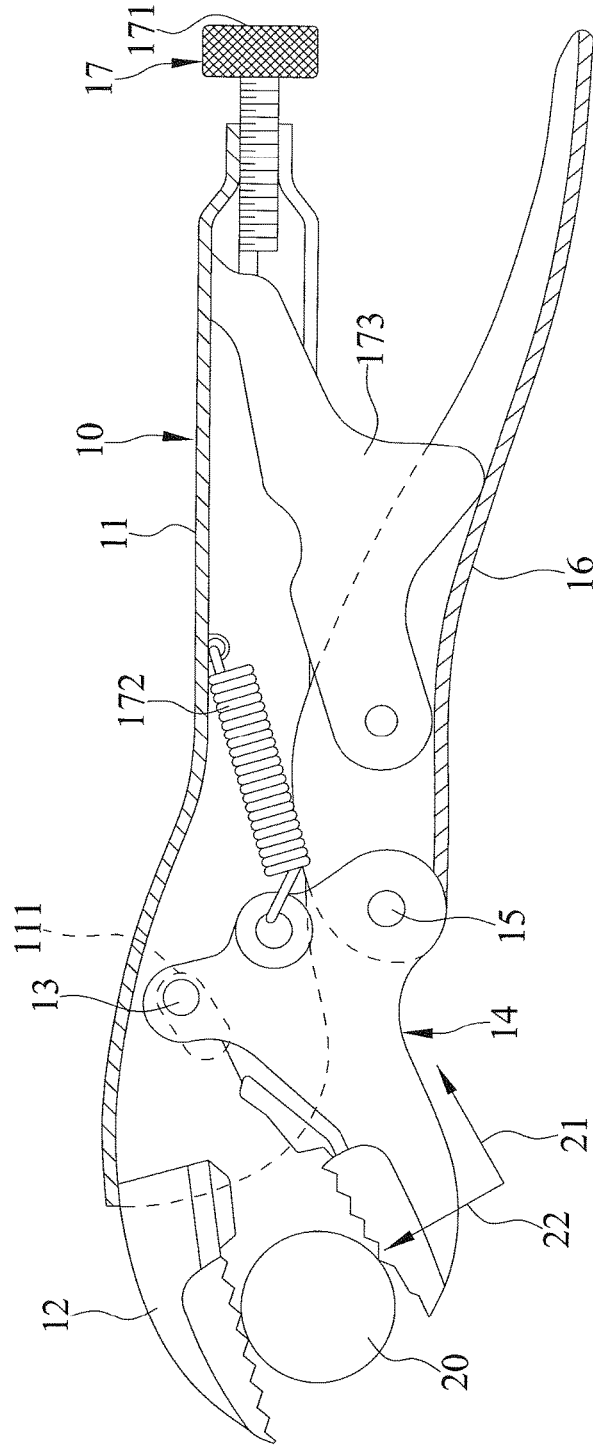

FIG. 3
PRIOR ART

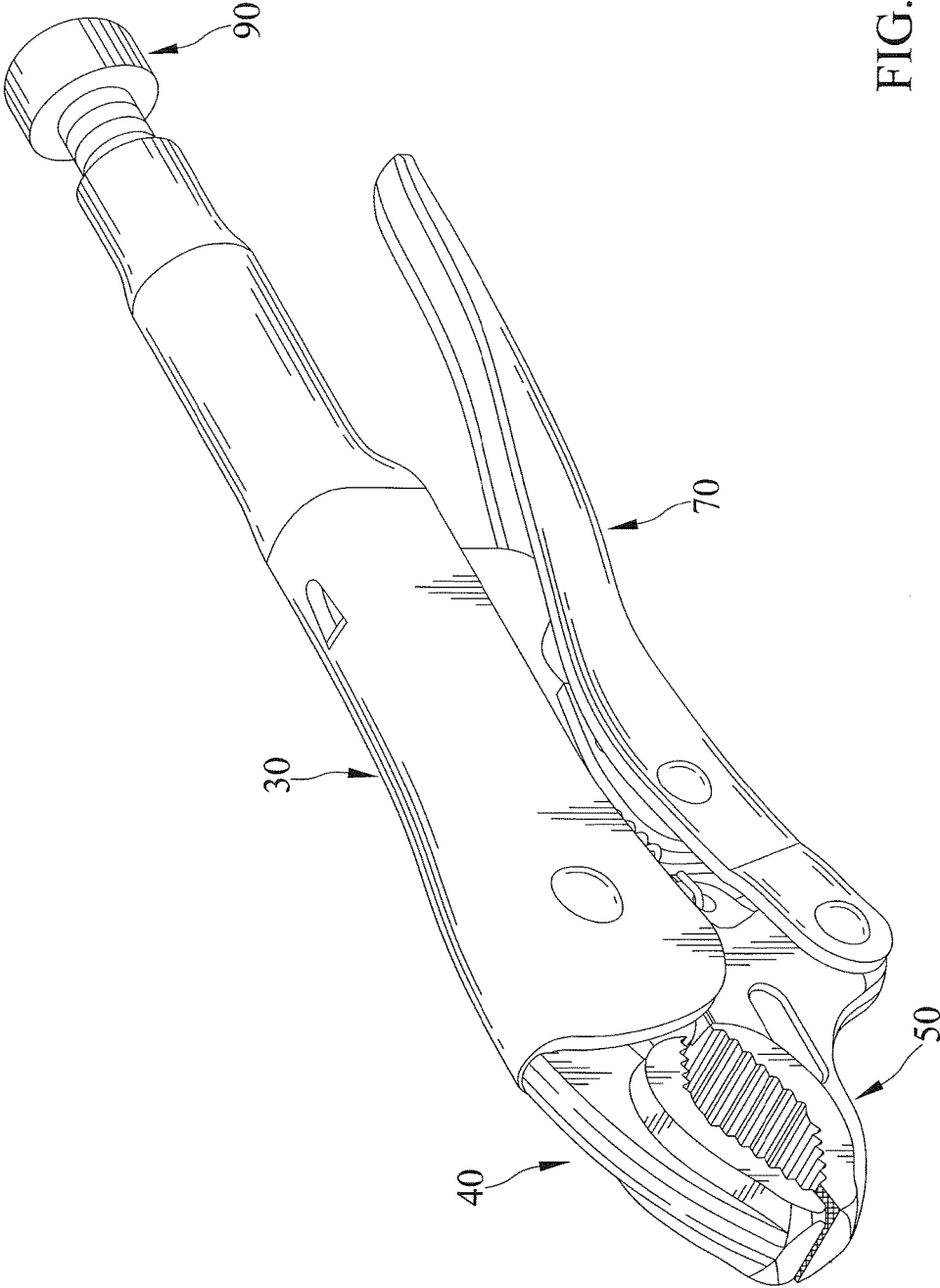

FIG. 4

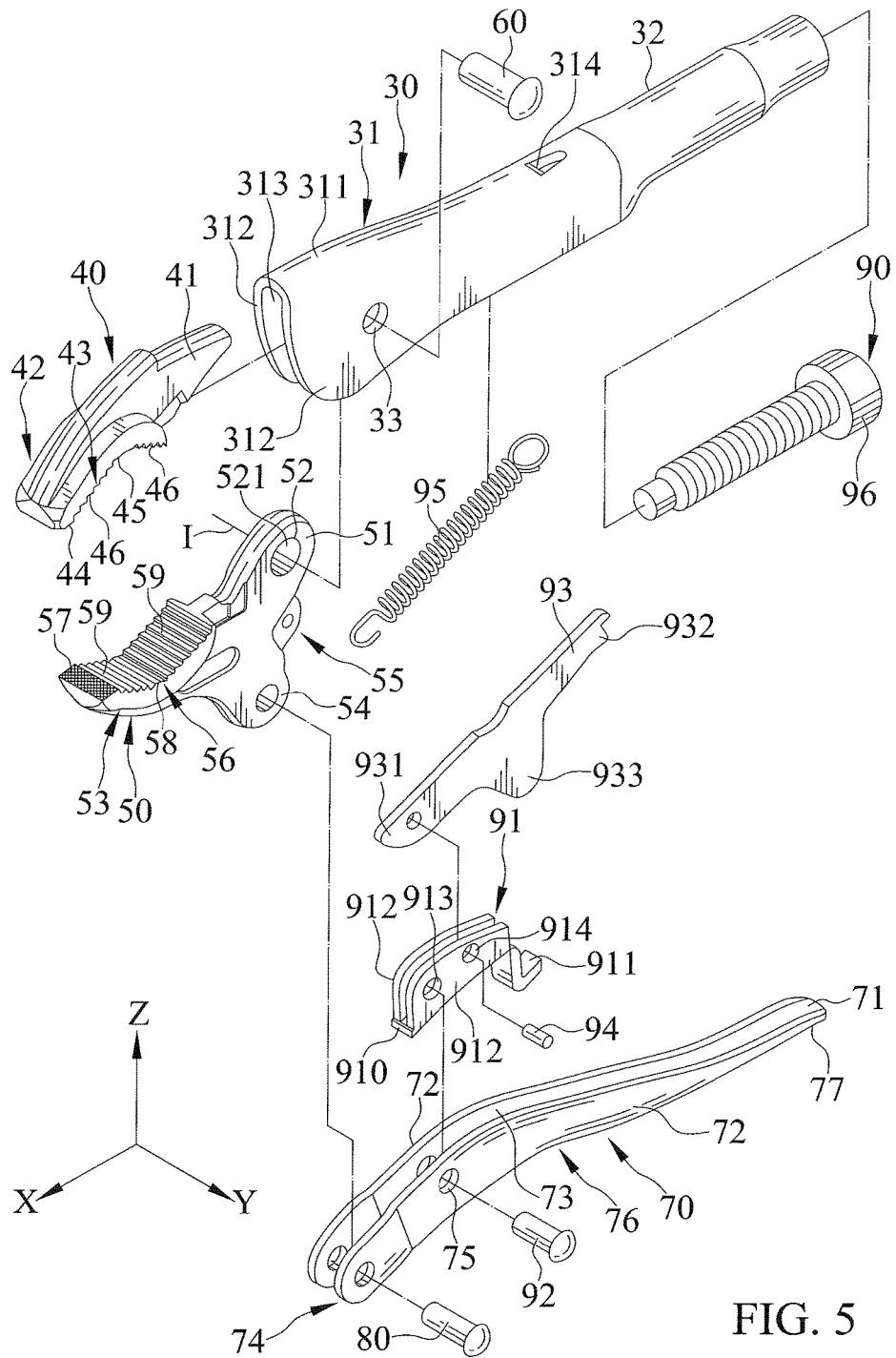

FIG. 5

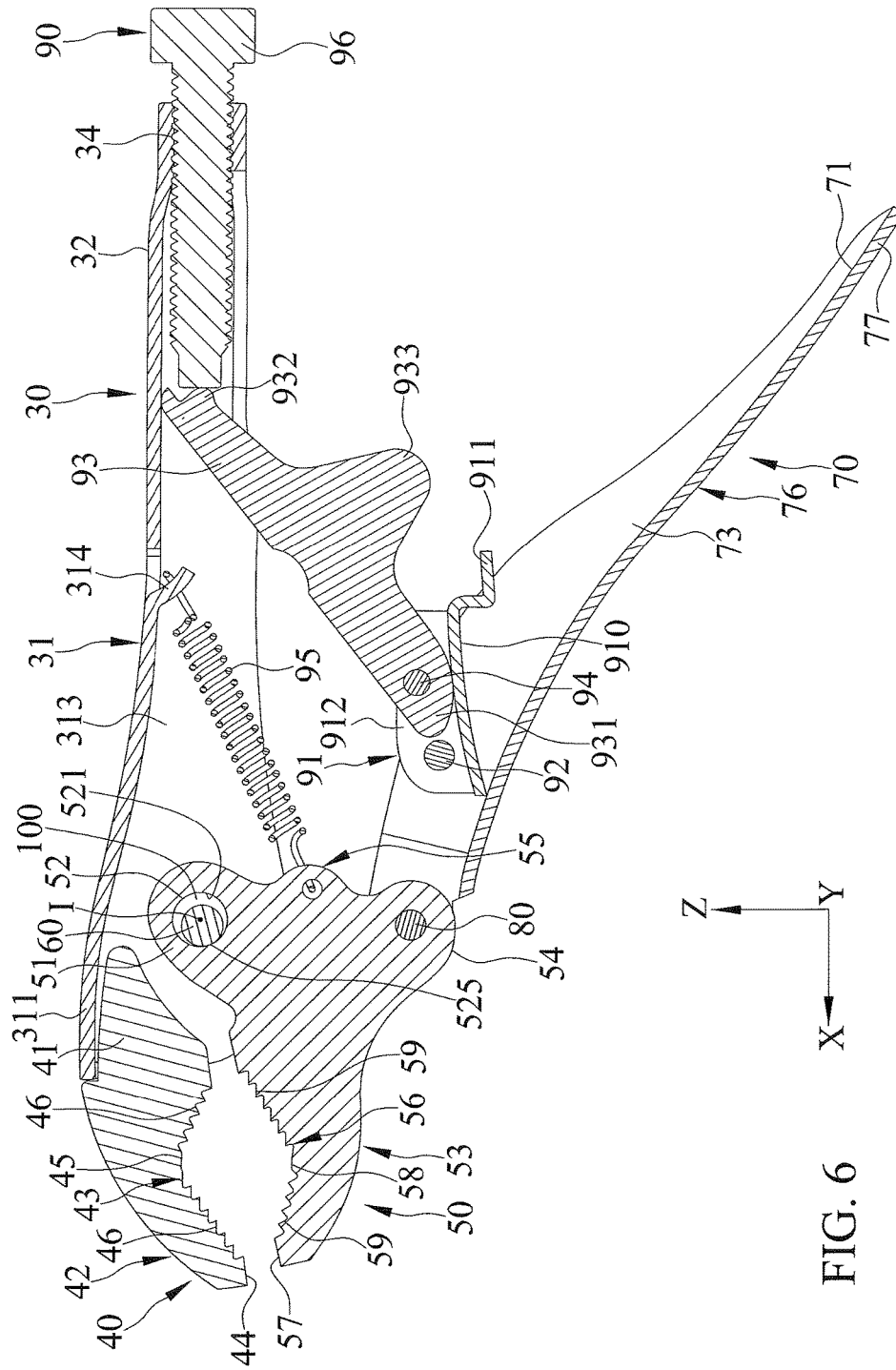

FIG. 6

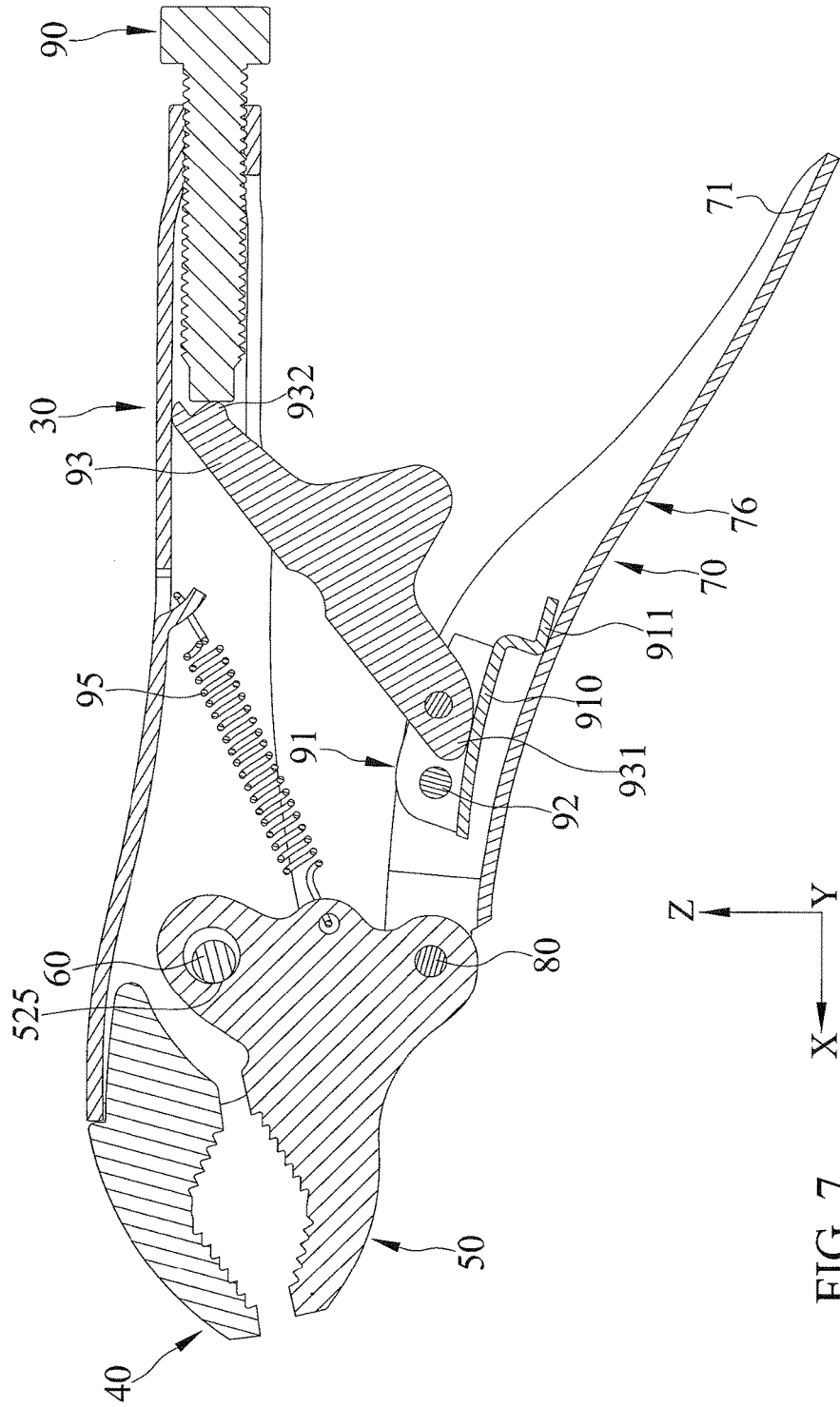

FIG. 7

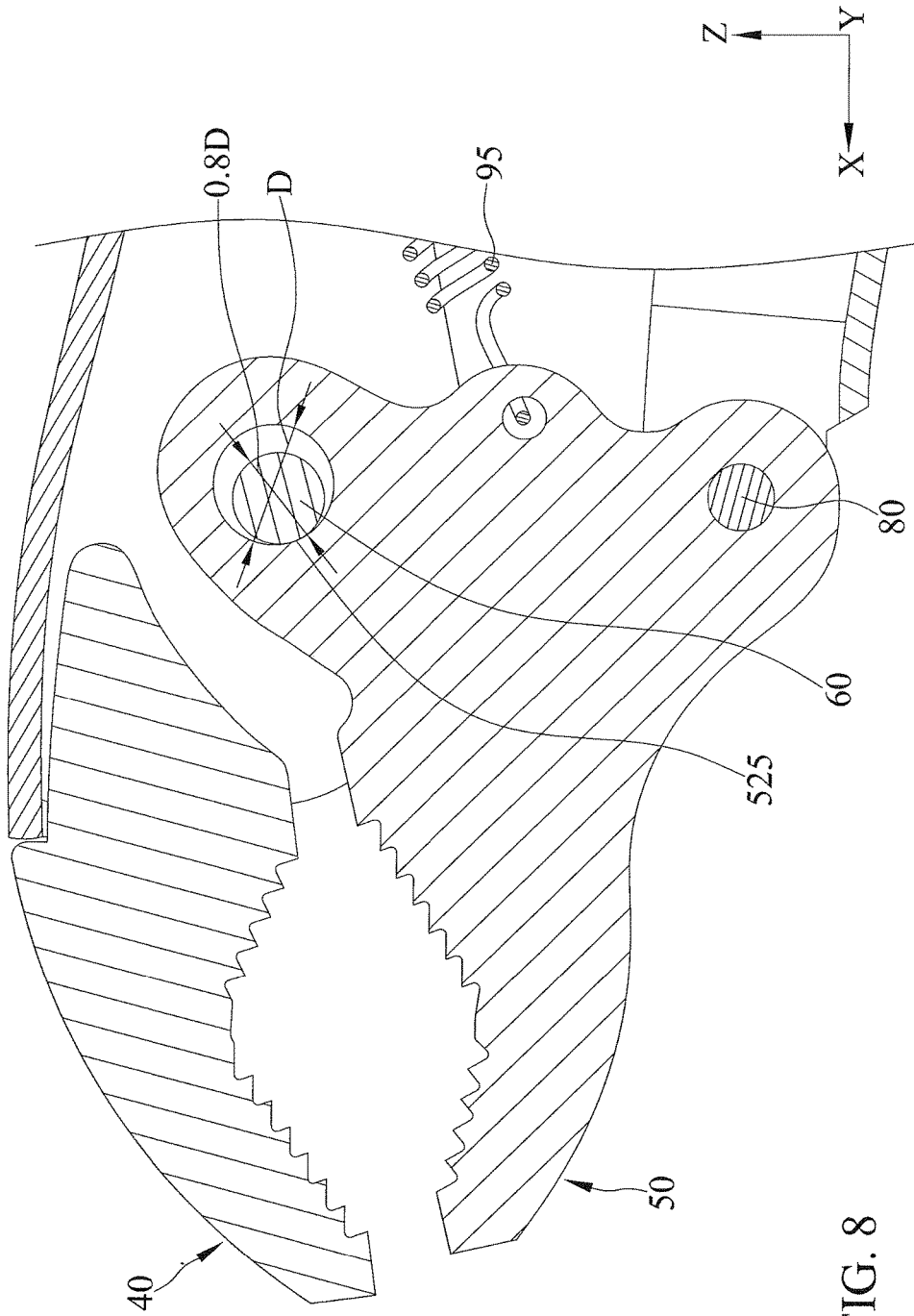

FIG. 8

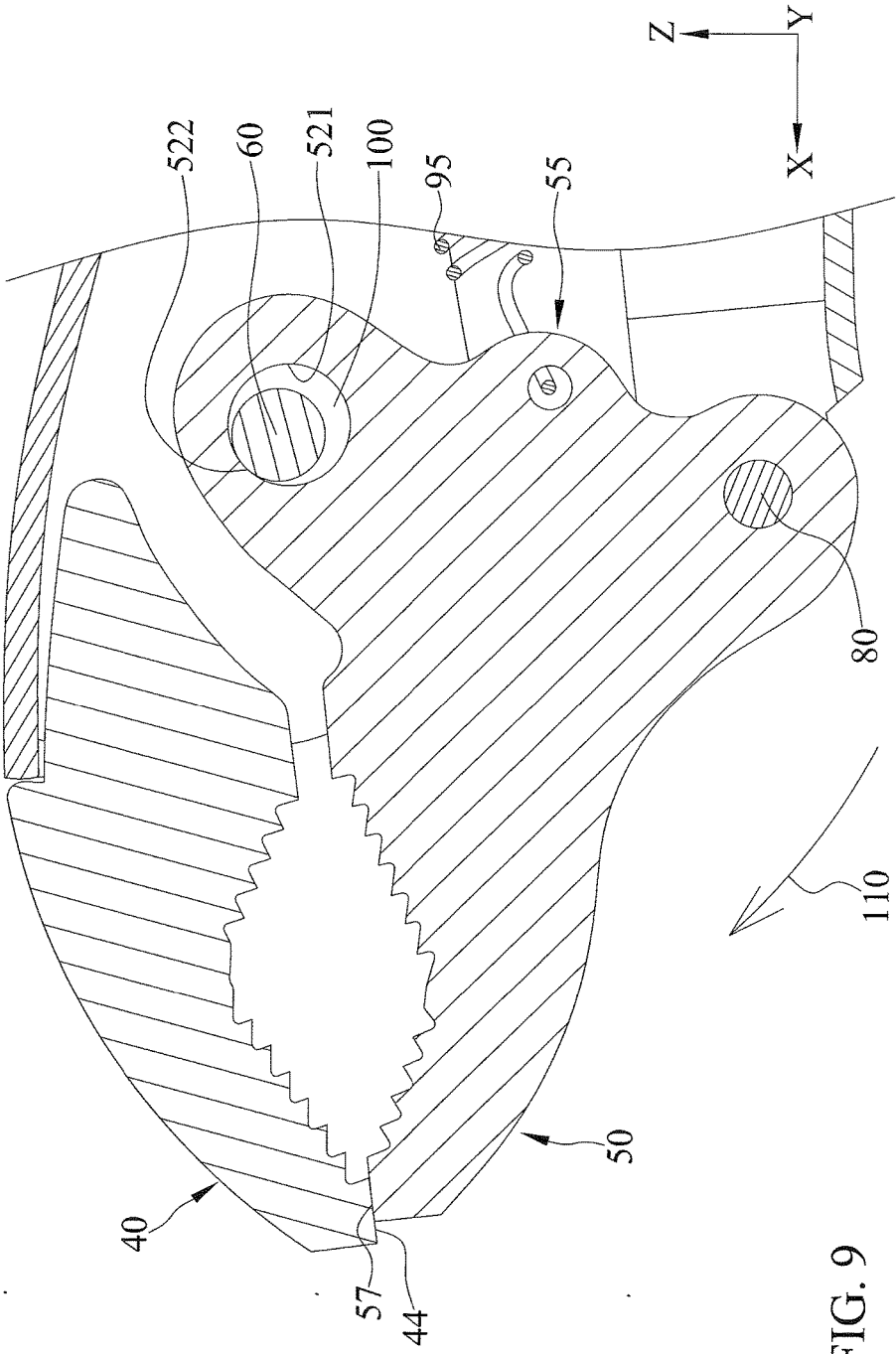

FIG. 9

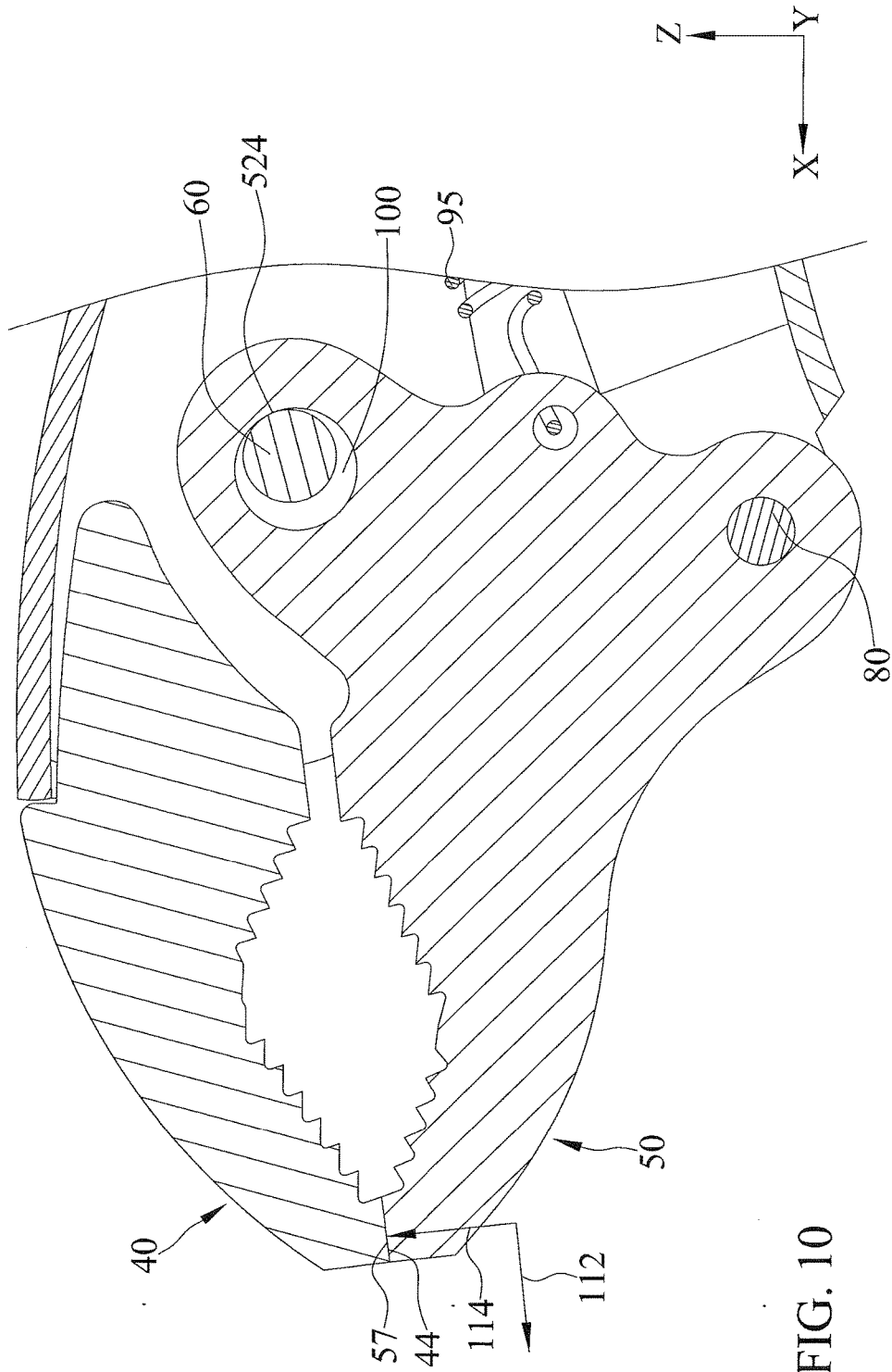

FIG. 10

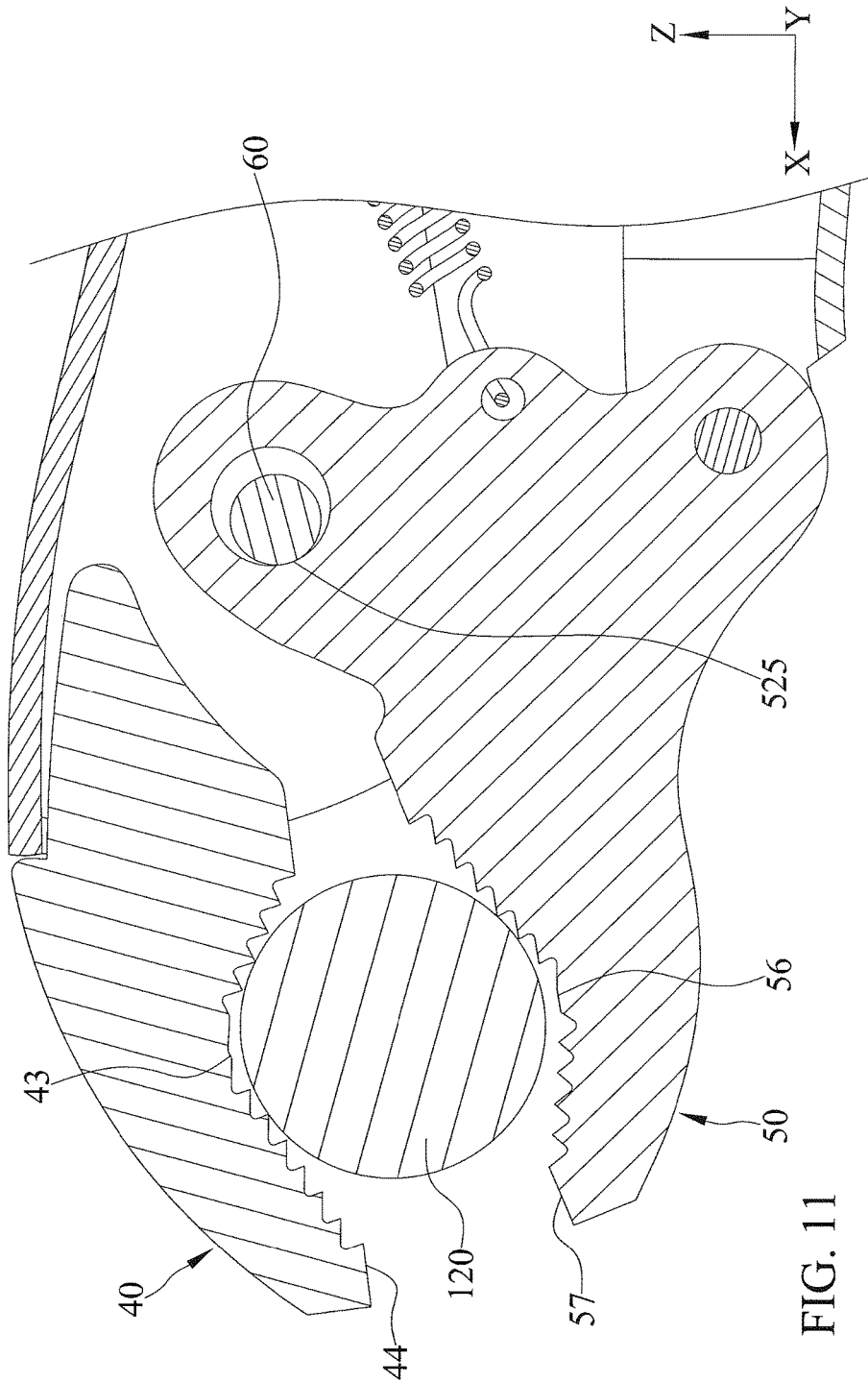

FIG. 11

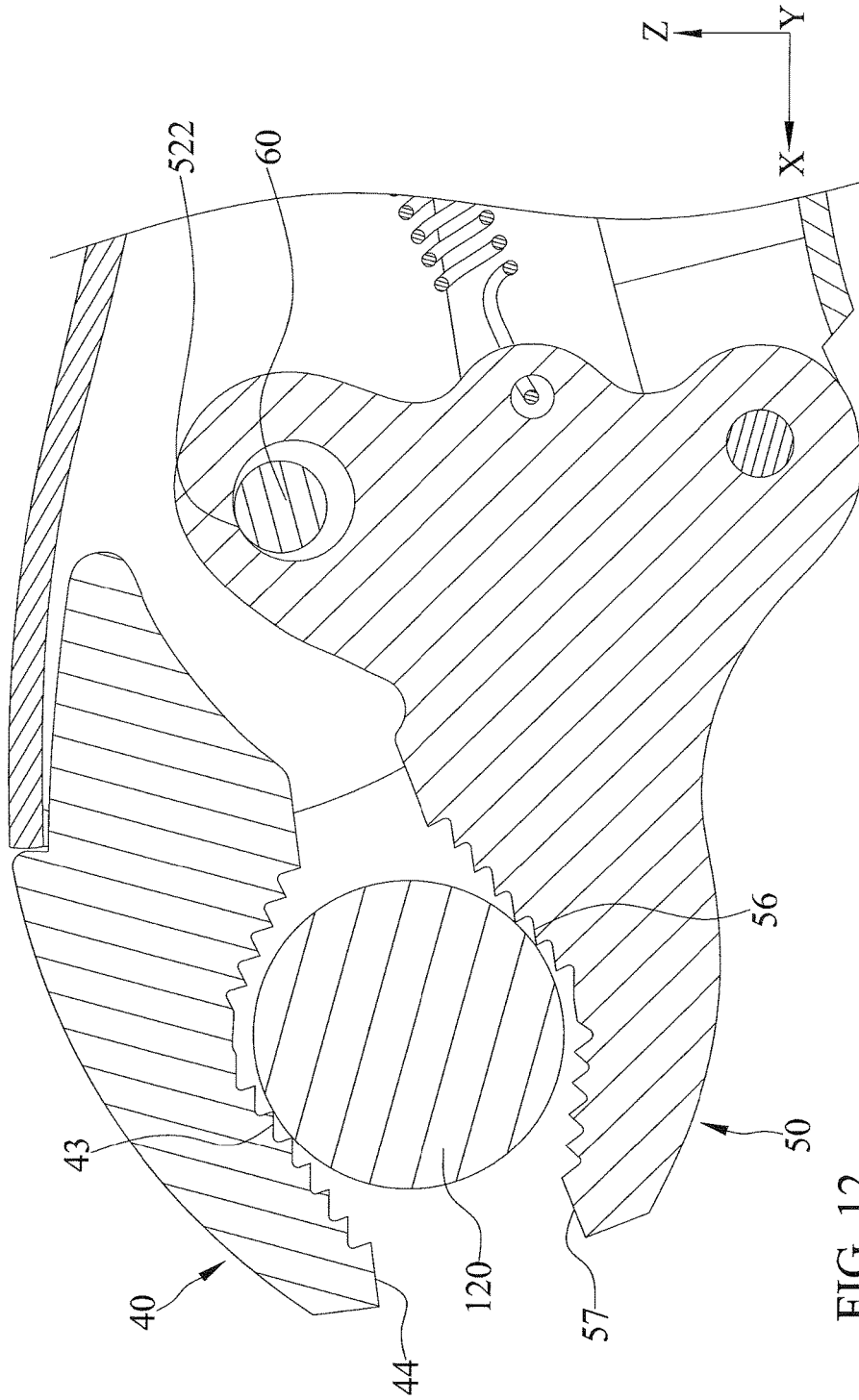

FIG. 12

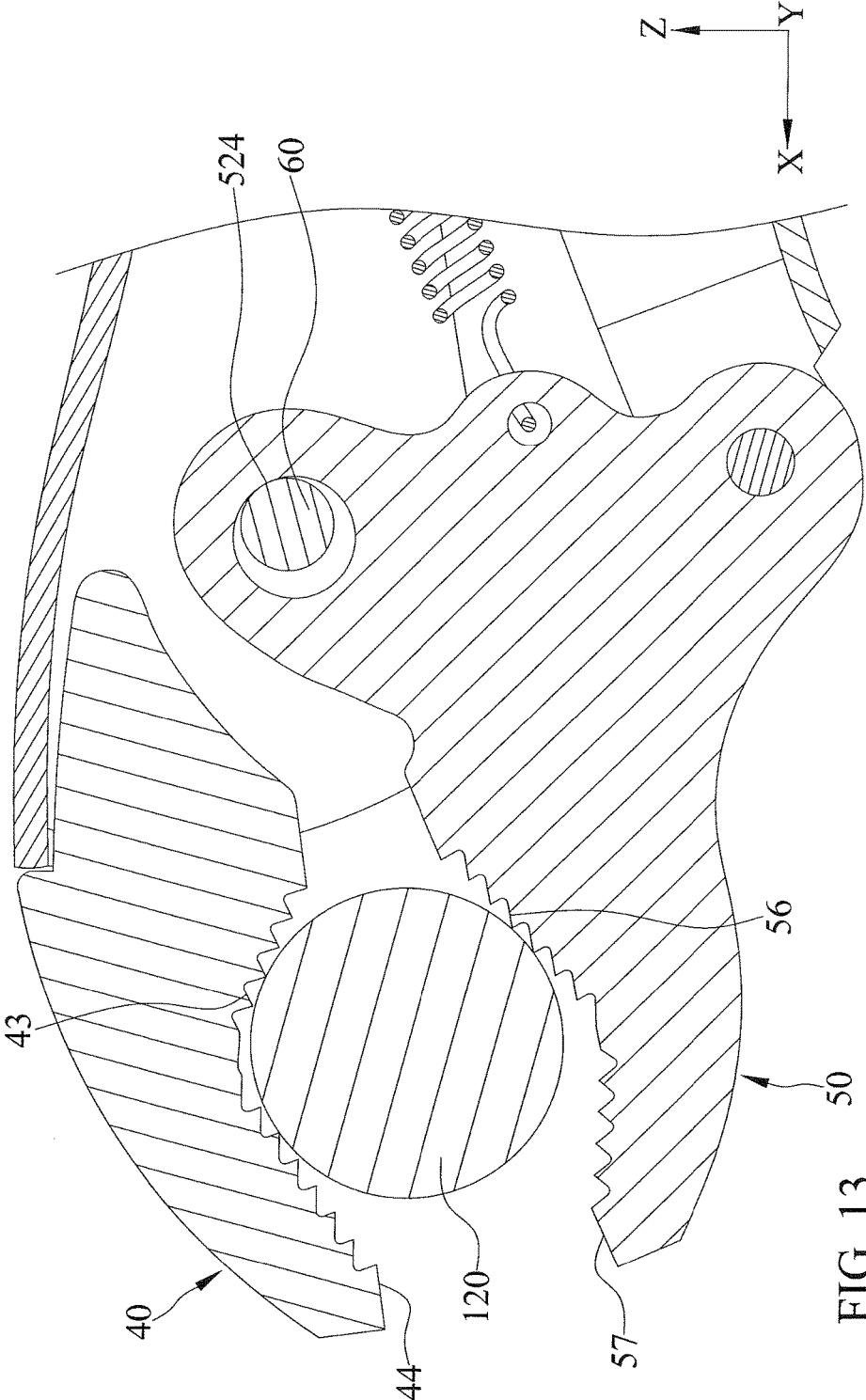

FIG. 13

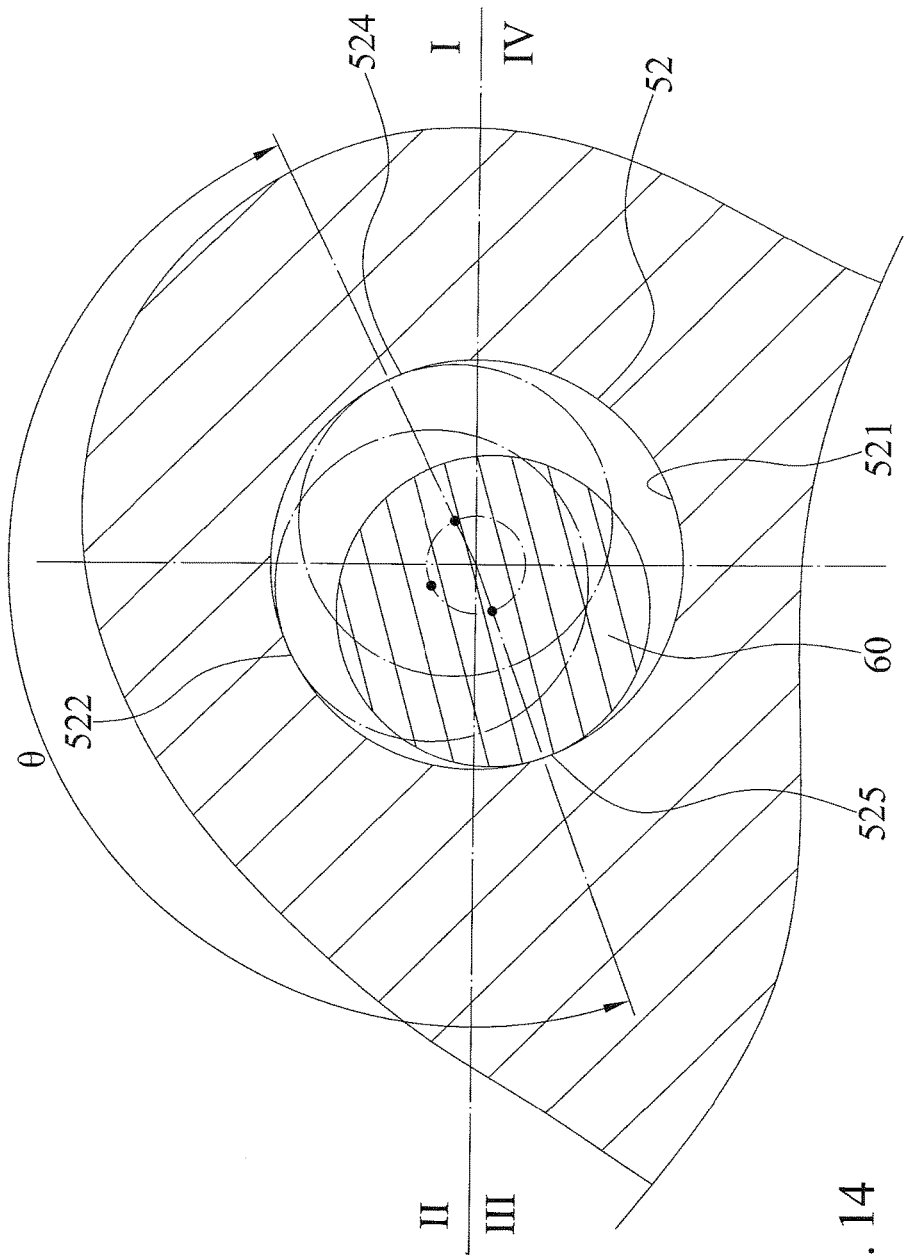

FIG. 14

LOCKING PLIERS

CROSS REFERENCE TO RELATED APPLICATION

The present application is a continuation-in-part application of U.S. patent application Ser. No. 13/469,469 filed on May 11, 2012, now U.S. Pat. No. 8,950,299, of which the entire disclosure is incorporated herein.

BACKGROUND OF THE INVENTION

1. Field of the Invention

This invention relates to a locking pliers and, more particularly, to a locking pliers that can be held firmly in a closed and locked position without the continuous application of force by a user while tightly gripping a workpiece.

2. Description of the Related Art

Referring to FIG. 1, a conventional locking pliers 10 disclosed in U.S. Pat. No. 7,861,622 B2 is shown to include a fixed handle 11 supporting a fixed jaw 12, a movable jaw 14 pivotally connected to the fixed handle 11 by a first pivot pin 13, a movable handle 16 pivotally connected to the movable jaw 14 by a second pivot pin 15, and a toggle-link locking mechanism 17 disposed to lock the movable jaw in a closed, locked position. The fixed handle 11 has an oval slotted aperture 111 such that the first pivot pin 13 is movable in the aperture 111 during use of the pliers 10. A long axis of the aperture 111 is arranged at an angle α with respect to a line extending through the center of the closed jaws 12 and 14. The angle α is approximately 15 degrees. The locking mechanism 17 has a link 173 pivotally connected to the movable handle 16 and in sliding and pivoting contact with an adjustment screw 171, and a biasing member 172 extending between the movable jaw 14 and the fixed handle 11 to bias the jaws 12 and 14 away from each other.

Referring to FIGS. 2 and 3, in operation, when the pliers is first locked onto a workpiece 20 and a turning force is applied to the pliers, the movable jaw 14 rotates clockwise around the second pivot pin 15 toward the fixed jaw 12 to allow a rearward movement of the first pivot pin 13 in the aperture 111. The movable jaw 14 is also moved rearward and toward the fixed jaw 12, as indicated by arrows 21 and 22, to increase the gripping force on the workpiece 20. Since the first pivot pin 13 is moved to a rear end of the aperture 111 when the jaws 12 and 14 are operated to the closed, locked position, the design of the aperture 111 is critical. However, the aperture 111 does not prevent a problem that a sliding engagement of the first pivot pin 13 with a wall defining the aperture 111 may be unstable. Therefore, the gripping force on the workpiece 20 is adversely affected. In addition, the aperture 111 has to be made precisely. If the axis of the aperture 111 suffers deviations from the angle α , the first pivot pin 13 can not move stably or even move rearward in the aperture 111.

SUMMARY OF THE INVENTION

An objective of the present invention is to provide a locking pliers which can exert a firm and stable gripping force onto a workpiece while being held firmly in a closed and locked position without continuous application of force by a user.

According to this invention, the locking pliers includes a fixed handle. A fixed jaw is connected securely to the fixed handle and includes a first clamping surface. A movable jaw cooperates with the fixed jaw and includes a second clamp-

ing surface and movable and fixed pivoting regions. A movable handle is pivotally connected to the movable pivoting region about a pivotal axis. A movable pivot unit includes a pivot pin engaging with the fixed handle and the fixed pivoting region and includes a pivot hole disposed in one of the fixed handle and the fixed pivoting region and configured and dimensioned to loosely receive the pivot pin. The pivot hole has a first diametrical size, and the pivot pin has a second diametrical size not greater than 0.8 times the first diametrical size. A biasing member engages with the fixed handle and the movable jaw, with the fixed handle and the movable jaw subject to a tensional force of the biasing member.

Upon changing the locking pliers from initial, locking, to tightening positions thereof, the pivot pin has an annular trajectory in the pivot hole, the movable jaw is pivoted closer toward the fixed jaw, and the pivot pin is in an abutting engagement with trailing, middle and leading regions defined from a contour of the pivot hole, respectively.

Other objectives, advantages, and new features of the present invention will become apparent from the following detailed description of the invention when considered in conjunction with the accompanied drawings.

BRIEF DESCRIPTION OF THE DRAWINGS

FIG. 1 is a partially sectioned side view of a conventional locking pliers disclosed in U.S. Pat. No. 7,861,622 B2 in a closed and locked position;

FIG. 2 is a partially sectioned side view of the conventional locking pliers in its closed, locked position on a workpiece;

FIG. 3 is a partially sectioned side view of the conventional locking pliers in its closed, locked position on a workpiece with a turning force applied to the pliers;

FIG. 4 is a perspective view of the preferred embodiment of a locking pliers according to this invention;

FIG. 5 is an exploded perspective view of the preferred embodiment of a locking pliers according to this invention;

FIG. 6 is a partially sectioned side view of the preferred embodiment in an opened state;

FIG. 7 is a partially sectioned side view of the preferred embodiment in an initially operating state;

FIG. 8 is a partially sectioned enlarged side view of FIG. 7.

FIG. 9 is a partially sectioned enlarged side view of the preferred embodiment in a locking state;

FIG. 10 is a partially sectioned enlarged side view of the preferred embodiment in a tightening state;

FIG. 11 is a partially sectioned enlarged side view of the preferred embodiment in a gripping state where a workpiece is gripped thereon;

FIG. 12 is a partially sectioned enlarged side view of the preferred embodiment in a locking state on the workpiece;

FIG. 13 is a partially sectioned enlarged side view of the preferred embodiment in a tightening state on the workpiece; and

FIG. 14 is a fragmentary sectional view of a movable pivot unit of the preferred embodiment.

DETAILED DESCRIPTION OF THE INVENTION

Referring to FIGS. 4 through 6, the preferred embodiment of a locking pliers according to the present invention is shown to comprise a fixed handle 30, a fixed jaw 40, a

movable jaw **50**, a movable handle **70**, a movable pivot unit, a biasing member **95**, and a lock unit **90**.

The fixed handle **30** has front and rear handle portions **31** and **32** opposite to each other in a longitudinal direction X. A pivot hole **33** and a screw hole **34** are formed in the front handle portion **31** and the rear handle portion **32**, respectively. In this embodiment, the front handle portion **31** is in the form of a grooved plate which includes an upper plate **311** and a pair of side plates **312** extending from the upper plate **311** in a transverse direction Z, which is transverse to the longitudinal direction X, to cooperatively define a recess **313**. The pivot and screw holes **33** and **34** are communicated with the recess **313**. A tab **314** extends from the upper plate **311** and into the recess **313**.

The fixed jaw **40** has a first connected portion **41** which is connected securely to the front handle portion **31**, and a first working portion **42** which extends forward in the longitudinal direction X from the first connected portion **41** and terminates at a first nose end **44** having a flat surface. The first working portion **42** has a fixed clamping surface **43** that is disposed immediately rearward in the longitudinal direction X from the first nose end **44** and that faces in the transverse direction Z and that is formed with gripping teeth **46** extending from the first nose end **44** along a concaved contour **45**.

The movable jaw **50** has a second connected portion **55** which extends in the transverse direction Z to terminate at fixed and movable pivoting regions **51** and **54**, and a second working portion **53** which extends forward in the longitudinal direction X from the second connected portion **55** and terminates at a second nose end **57** having a flat surface. The second working portion **53** has a movable clamping surface **56** that is disposed immediately rearward in the longitudinal direction X from the second nose end **57** and that confronts the fixed clamping surface **43** and that is formed with gripping teeth **59** extending rearward from the second nose end **57** along a concaved contour **58**.

The movable handle **70** has a front pivot portion **74** which is pivotally connected to the movable pivoting region **54** by a pivotal pin **80** about a pivotal axis, which has a fixed position, in an axial direction Y that is transverse to the longitudinal and transverse directions X and Z, and a rear actuating portion **76** which extends rearward from the front pivot portion **74** in the longitudinal direction X and terminates at a movable handle end **77** that is manually operable. In this embodiment, the movable handle **70** is in the form of a grooved plate which includes a base seat **71** and a pair of wings **72** that extend from the base seat **71** in the transverse direction Z and that are spaced apart from each other in the axial direction Y to cooperatively define a concavity **73**.

Referring to FIGS. **6** and **14**, a movable pivot unit includes a pivot pin **60** and a pivot hole **52**. The pivot pin **60** is disposed on the front handle portion **31** through the pivot hole **33** and extends along a pivot axis parallel to the pivotal axis of the pivotal pin **80**. The pivot pin **60** has a circular contour. The pivot hole **52** is disposed in the fixed pivoting region **51** of the movable jaw **50**. Alternatively, the pivot pin **60** may be disposed on the fixed pivoting region **51** of the movable jaw **50** while the pivot hole **52** is disposed in the front handle portion **31**. The pivot hole **52** has an inner periphery defining an inner tubular surface **521**. The inner tubular surface **521** has a circular contour. A central axis I extends through a center of the pivot hole **52**. The inner tubular surface **521** of the pivot hole **52** includes the contour thereof defining a first contour section and a second contour section. The first and second contour sections delimit the inner periphery of the pivot hole **52**. The first contour section

is opposite the second contour section. Leading, middle and trailing regions **524**, **522**, and **525** extend one after another and are angularly displaced from one another about the central axis I and are defined on the first contour section of the inner tubular surface **521**. The first contour section of the inner tubular surface **521** includes the leading, middle, and trailing regions **524**, **522**, and **525** sequentially in a counterclockwise direction. The pivot hole **52** has a diameter larger than that of the pivot pin **60**. The pivot hole **52** has a diametrical size D. The pivot pin **60** has a diametrical size 0.8D. The pivot pin **60** having a diametrical size not greater than 0.8D is also within the scope of the invention. In this embodiment, a subtended angle θ by the first contour section at the center of the pivot hole **52** ranges from 180 degrees to 270 degrees. Accordingly, a subtended angle by the second contour section at the center of the pivot hole **52** may range from 90 degrees to 180 degrees. The pivot pin **60** is angularly displaceable relative to and is able to be in continuous contact with the first contour section of the inner tubular surface **521** upon changing the locking pliers among initial, locking, and tightening positions thereof. The pivot pin **60** is in abutting engagement with the trailing, middle and leading regions **525**, **522**, and **524**, respectively, and a center of the pivot pin **60** is displaceable in III, II, and I quadrants, respectively. The pivot pin **60** is displaceable in an annular trajectory as it moves on the trailing, middle, and leading regions sequentially **525**, **522**, and **524** or in reverse, and the movable clamping surface **56** is close, closer and closest to the fixed clamping surface **43**, respectively, as will be described hereinafter. Since the pivot pin **60** moves in an annular trajectory, it is subject to a horizontal component force and a vertical component force. The vertical component force helps maintain the pivot pin **60** in a continuous contact with the first contour section of the inner tubular surface **521** of the pivot hole **52** when the pivot pin **60** moves on the trailing, middle and leading regions **525**, **522**, and **524**.

The biasing member **95** is connected to the tab **314** and the second connected portion **55** to bias the movable jaw **50**. Therefore, the fixed handle **30** and the movable jaw **50** are subject to a tensional force of the biasing member **95**. The biasing member **95** is released from tension when the locking pliers is in the initial position thereof. In this embodiment, the biasing member **95** is a tension spring.

The lock unit **90** is a toggle locking assembly which includes a linkage interconnecting the fixed and movable handles **30** and **70**. The linkage includes a first linkage **91** and a second linkage **93**. The first linkage **91** is disposed in the concavity **73** and has a first proximate end **913** pivotally connected to the rear actuating portion **76** of the movable handle **70** by a first linking pin **92** about a first linking axis and a first distal end **914**. In this embodiment, the first linkage **91** is a grooved plate and has a lever wall **910** that extends rearward in the longitudinal direction X and terminates at a power end **911** and a pair of side walls **912** that extend in the transverse direction Z from the lever wall **910**. The second linkage **93** has a second proximate end **931** which is pivotally connected to the first distal end **914** by a second linking pin **94** about a second linking axis, a second distal end **932** that is disposed in the recess **313** and slidably and retainingly engaged with the rear handle portion **32** and that is contact with an adjustment screw **96** which is threadedly engaged with the screw hole **34**, and a protrusion **933** which extends rearward to serve as a stop. The adjustment screw **96** can be operated to adjust a separating distance between the fixed and movable jaws **40** and **50**. Accordingly,

the protrusion **933** abuts against and stops on the base seat **71** when the locking pliers is in the tightening position thereof.

In this embodiment, each of the pivot pin **60**, the pivotal pin **80**, and the first and second linking pins **92** and **94** is a rivet.

During operation, as shown in FIG. 6, when the locking pliers is in the initial position thereof, the movable handle **70** is disposed away from the fixed handle **30**, the power end **911** of the first linkage **91** is turned by the second linkage **93** about the first linking axis to be spaced apart from the base seat **71** in the transverse direction *Z*, and the pivot pin **60** is in abutting engagement with the trailing region **525** and is spaced apart from the leading region **524** by a clearance **100**. In addition, the pivot pin **60** is disengaged from the second contour section of the inner tubular surface **521** of the pivot hole **52**.

As shown in FIGS. 6, 7, and 8, when a manual turning force is applied to move the movable handle **70** toward the fixed handle **30** to permit the power end **911** to contact with the base seat **71**, the movable jaw **50** is turned toward the fixed jaw **40**. While the movable jaw **50** is turned toward the fixed jaw **40**, the pivot pin **60** is disengaged from the second contour section of the inner tubular surface **521** of the pivot hole **52**.

As shown in FIGS. 7 and 9, the manual turning force is continued to be applied to the movable handle **70**. Consequently, the second linkage **93** is turned clockwise about the second linking axis of the second linking pin **94**. Hence, the movable jaw **50** is turned clockwise as indicated by the arrow **110** about the pivotal axis of the pivotal pin **80** against the biasing action of the biasing member **95**, and the locking pliers is in the locking position thereof when the second nose end **57** abuts against the first nose end **44**, when the pivot pin **60** is in abutting engagement with the middle region **522**, and when the clearance **100** is disposed lower than the pivot pin **60** and between the pivot pin **60** and the inner tubular surface **521**. The pivot pin **60** is also disengaged from the second contour section of the inner tubular surface **521** of the pivot hole **52** when the locking pliers is in the locking position thereof. In addition, when the movable jaw **50** is displaced from a position when the locking pliers is in the initial position thereof to another position when the locking pliers is in the locking position thereof, the lever wall **910** causes the second proximate end **931** to displace to a first over-center position in which the pivotal axis of the pivotal pin **80**, the second linking axis of the second linking pin **94**, and the second distal end **932** are in a near straight line with the first linking axis of the first linking pin **92**, thereby holding the movable jaw **50** in a locking position thereof.

As shown in FIGS. 9 and 10, when the manual turning force is continued to be applied to the movable handle end **77** toward the rear handle portion **32** to permit the protrusion **933** to contact with the base seat **71**, the movable jaw **50** is forced to turn clockwise about the pivotal axis of the pivotal pin **80** and is subject to a force component in a direction **112** to move forward and another force component in a direction **114** to bring the flat surfaces of the first and second nose ends **44**, **57** into full abutment with each other. The locking pliers is in the tightening position thereof when the first and second nose ends **44** and **57** abut against one another, when the pivot pin **60** is permitted to be in abutting engagement with the leading region **524** and is spaced apart from the trailing region **525**, and when the clearance **100** is disposed in front of the pivot pin **60** and between the pivot pin **60** and the inner tubular surface **521**. The pivot pin **60** is also disengaged from the second contour section of the inner tubular

surface **521** of the pivot hole **52** when the locking pliers is in the tightening position thereof. In addition, when the movable jaw **50** is displaced from the position when the locking pliers is in locking position thereof to a position when the locking pliers is in the tightening position thereof, the second proximate end **931** is caused by the lever wall **910** to turn about the second linking axis of the second linking pin **94** to be shifted to a second over-center position in which the pivotal axis of the pivotal pin **80**, the second linking axis of the second linking pin **94**, and the second distal end **932** are in a substantially straight line with the first linking axis of the first linking pin **92**, thereby holding the movable jaw **50** in a tightening position thereof.

Therefore, once the manual turning force on the movable handle **70** is eliminated after continuing turning the movable jaw **50** clockwise about the pivotal axis of the pivotal pin **80**, a friction force generated as a result of the abutting engagement between the pivot pin **60** and the leading region **524** counteracts the biasing action of the biasing member **95** to prevent the movable clamping surface **56** from moving away when the locking pliers is in the tightening position thereof. As a result, the gripping force between the fixed and movable clamping surfaces **43** and **56** is firm and stable during the operation of the locking pliers to the tightening position thereof.

When it is desired to release the movable jaw **50** from the tightening position thereof, an opposite manual turning force is applied to the movable handle **70** away from the rear handle portion **32** to permit the movable jaw **50** to move back to the initial position by the biasing action of the biasing member **95**.

In use, referring to FIGS. 11 to 13, a workpiece **120** is shown to be gripped by the clamping surfaces **43** and **56**. The workpiece **120** is gripped firmly with the concaved gripping teeth **46** and **59**. Firstly, the movable jaw **50** is opened relative to the fixed jaw **40** so the workpiece **120** can be placed therebetween. Subsequently, the movable handle **70** is turned toward the rear handle portion **32** to turn the movable jaw **50** toward the fixed jaw **40**, thereby permitting the clamping surfaces **43** and **56** to lock on the workpiece **120**. Finally, the manual turning force is continued to be applied to the movable handle **70**, and when the locking pliers is in the tightening position thereof, the movable jaw **50** is tightly gripped by the gripping teeth **46** and **59** of the respective clamping surfaces **43** and **56**.

As illustrated, since the pivot pin **60** is kept in the abutting engagement with the inner tubular surface **521** during the operation of the locking pliers, and since the movable jaw **50** is moved forward and toward the fixed jaw **40** when the manual turning force is further applied to the movable handle **70** to displace the movable jaw **50** from the position when the locking pliers is in the locking position thereof to the position when the locking pliers is in the tightening position thereof, the gripping force is increased and stable.

While the present invention has been described in connection with what is considered the most practical and preferred embodiments, it is understood that this invention is not limited to the disclosed embodiments but is intended to cover various arrangements included within the spirit and scope of the broadest interpretations and equivalent arrangements.

What is claimed is:

1. A locking pliers comprising:
 - a fixed handle;
 - a fixed jaw connected securely to the fixed handle and including a first clamping surface;

a movable jaw cooperating with the fixed jaw and including a second clamping surface and movable and fixed pivoting regions;

a movable handle pivotally connected to the movable pivoting region about a pivotal axis;

a movable pivot unit including a pivot pin engaging with the fixed handle and the fixed pivoting region;

a pivot hole disposed in one of the fixed handle and the fixed pivoting region, with the pivot hole configured to form a contour of a circular shape defining trailing, middle and leading regions, with the circular shape of the pivot hole having a first diametrical size and the pivot pin having a second diametrical size not greater than 0.8 times the first diametrical size, with the pivot pin received and movable along an annular trajectory relative to the pivot pin in the pivot hole and partially abutting against the contour of the pivot hole; and

a biasing member engaging with the fixed handle and the movable jaw, with the fixed handle and the movable jaw subject to a tensional force of the biasing member; wherein the fixed and movable handles are movable from initial, locking, to tightening positions, the pivot pin has the annular trajectory in the pivot hole, and the movable jaw is pivoted closer toward the fixed jaw, and the pivot pin is in abutting engagement with the trailing, middle and leading regions defined from the contour of the pivot hole, respectively.

2. The locking pliers as claimed in claim 1, wherein the contour of the pivot hole defines a first contour section and a second contour section opposite the first contour section, wherein the trailing, middle and leading regions extend one after another and are angularly displaced from one another and are defined on the first contour section.

3. The locking pliers as claimed in claim 2, wherein the pivot pin is disengaged from the second contour section.

4. The locking pliers as claimed in claim 3, wherein the first and second contour sections delimit an inner periphery of the pivot hole.

5. The locking pliers as claimed in claim 3, wherein the pivot axis is in a fixed position relative to the movable handle and the movable pivoting region.

6. The locking pliers as claimed in claim 3, wherein the pivot pin has a circular contour.

7. The locking pliers as claimed in claim 2, wherein the pivot axis is in a fixed position relative to the movable handle and the movable pivoting region.

8. The locking pliers as claimed in claim 2, wherein the pivot pin has a circular contour.

9. The locking pliers as claimed in claim 1, wherein the pivot axis is in a fixed position relative to the movable handle and the movable pivoting region.

10. The locking pliers as claimed in claim 1 further comprising a lock unit including an adjustment screw to control a separating distance between the fixed and movable jaws, and wherein the adjustment screw is threadedly engaged with the fixed handle.

11. The locking pliers as claimed in claim 10, wherein the lock unit includes a linkage interconnecting the fixed and movable handles, wherein the linkage includes first and second linkages, wherein the first linkage has a first proximate end pivotally connected to the movable handle about a first linking axis and a first distal end, and wherein the second linkage has a second proximate end pivotally connected to the first distal end about a second linking axis and a second distal end connected to the fixed handle.

12. The locking pliers as claimed in claim 11, wherein the pivot axis, the linking axis and the second distal end are in a near straight line with the first linking axis when the fixed and movable handles are in the locking position thereof.

13. The locking pliers as claimed in claim 11, wherein the pivot axis, the linking axis and the second distal end are in a substantially straight line with the first linking axis when the fixed and movable handles are in the tightening position thereof.

* * * * *