



US010173893B2

(12) **United States Patent**
Quevy et al.

(10) **Patent No.:** **US 10,173,893 B2**

(45) **Date of Patent:** ***Jan. 8, 2019**

(54) **METHODS AND STRUCTURES FOR THIN-FILM ENCAPSULATION AND CO-INTEGRATION OF SAME WITH MICROELECTRONIC DEVICES AND MICROELECTROMECHANICAL SYSTEMS (MEMS)**

(51) **Int. Cl.**
B81C 1/00 (2006.01)
B81B 3/00 (2006.01)
(Continued)

(52) **U.S. Cl.**
CPC **B81C 1/00246** (2013.01); **B81B 3/0021** (2013.01); **B81B 7/007** (2013.01);
(Continued)

(58) **Field of Classification Search**
CPC B81C 1/00269
See application file for complete search history.

(71) Applicant: **Semiconductor Manufacturing International (Shanghai) Corporation**, Shanghai (CN)

(72) Inventors: **Emmanuel P. Quevy**, El Cerrito, CA (US); **Jeremy R. Hui**, San Jose, CA (US); **Carrie Wing-Zin Low**, Union City, CA (US); **Mehrnaz Motiee**, San Francisco, CA (US)

(56) **References Cited**
U.S. PATENT DOCUMENTS

7,923,790 B1 * 4/2011 Quevy B81B 7/02
257/414
8,716,852 B2 * 5/2014 Shu B81B 7/0038
257/254

(73) Assignee: **SEMICONDUCTOR MANUFACTURING INTERNATIONAL (SHANGHAI) CORPORATION**, Shanghai (CN)

(Continued)
Primary Examiner — Caridad Everhart
Assistant Examiner — Ankush Singal
(74) *Attorney, Agent, or Firm* — Kilpatrick Townsend & Stockton LLP

(*) Notice: Subject to any disclaimer, the term of this patent is extended or adjusted under 35 U.S.C. 154(b) by 0 days.
This patent is subject to a terminal disclaimer.

(57) **ABSTRACT**
Methods and structures that may be implemented in one example to co-integrate processes for thin-film encapsulation and formation of microelectronic devices and microelectromechanical systems (MEMS) such as sensors and actuators. For example, structures having varying characteristics may be fabricated using the same basic process flow by selecting among different process options or modules for use with the basic process flow in order to create the desired structure/s. Various process flow sequences as well as a variety of device design structures may be advantageously enabled by the various disclosed process flow sequences.

(21) Appl. No.: **15/246,278**

(22) Filed: **Aug. 24, 2016**

(65) **Prior Publication Data**
US 2016/0362295 A1 Dec. 15, 2016

Related U.S. Application Data
(62) Division of application No. 14/532,658, filed on Nov. 4, 2014, now Pat. No. 9,428,377.
(Continued)

16 Claims, 13 Drawing Sheets

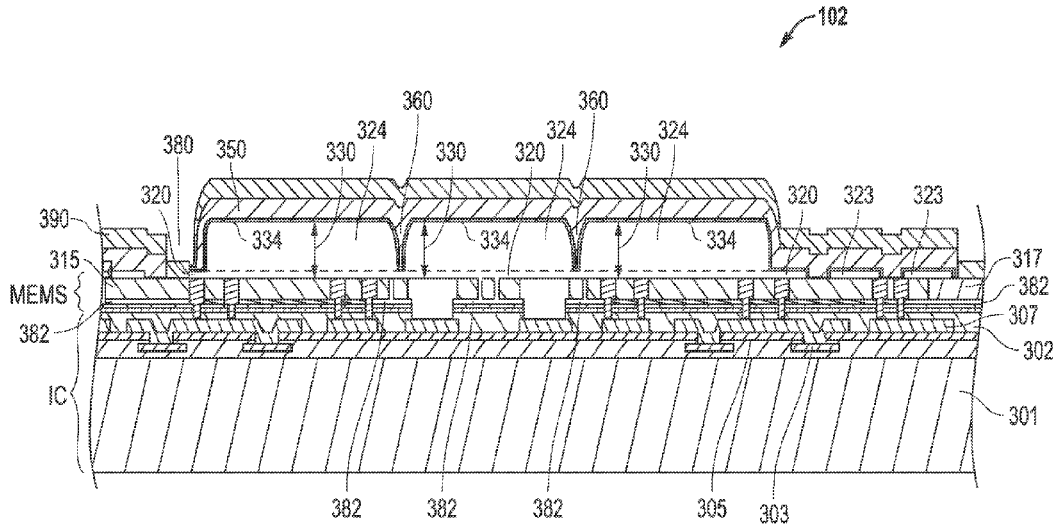

Related U.S. Application Data

(60) Provisional application No. 62/029,233, filed on Jul. 25, 2014.

(51) **Int. Cl.**
B81B 7/00 (2006.01)
G01N 27/22 (2006.01)

(52) **U.S. Cl.**
CPC **B81B 7/008** (2013.01); **B81B 7/0077** (2013.01); **B81C 1/0038** (2013.01); **B81C 1/00158** (2013.01); **B81C 1/00269** (2013.01); **B81C 1/00285** (2013.01); **B81C 1/00333** (2013.01); **G01N 27/223** (2013.01); **G01N 27/227** (2013.01); **B81B 2201/0214** (2013.01); **B81B 2201/0235** (2013.01); **B81B 2201/0264** (2013.01); **B81B 2203/0127** (2013.01); **B81B**

2203/0315 (2013.01); **B81C 2201/0105** (2013.01); **B81C 2201/056** (2013.01); **B81C 2203/019** (2013.01); **B81C 2203/0118** (2013.01); **B81C 2203/0136** (2013.01); **B81C 2203/0172** (2013.01); **B81C 2203/0735** (2013.01)

(56) **References Cited**

U.S. PATENT DOCUMENTS

2009/0275163 A1* 11/2009 Lacey B81C 1/00333
438/51
2012/0211805 A1* 8/2012 Winkler B81C 1/00246
257/254
2013/0193527 A1* 8/2013 Chu H01L 21/76898
257/414

* cited by examiner

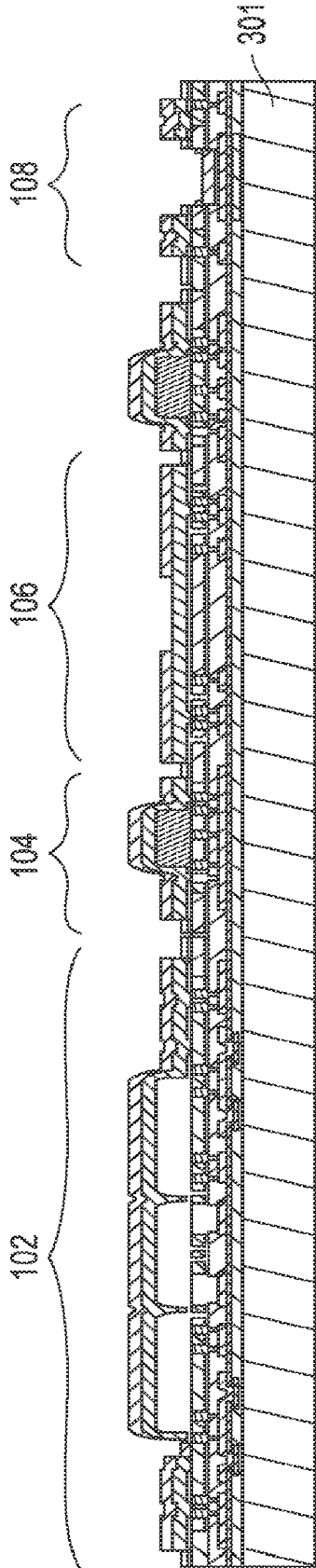

FIG. 1

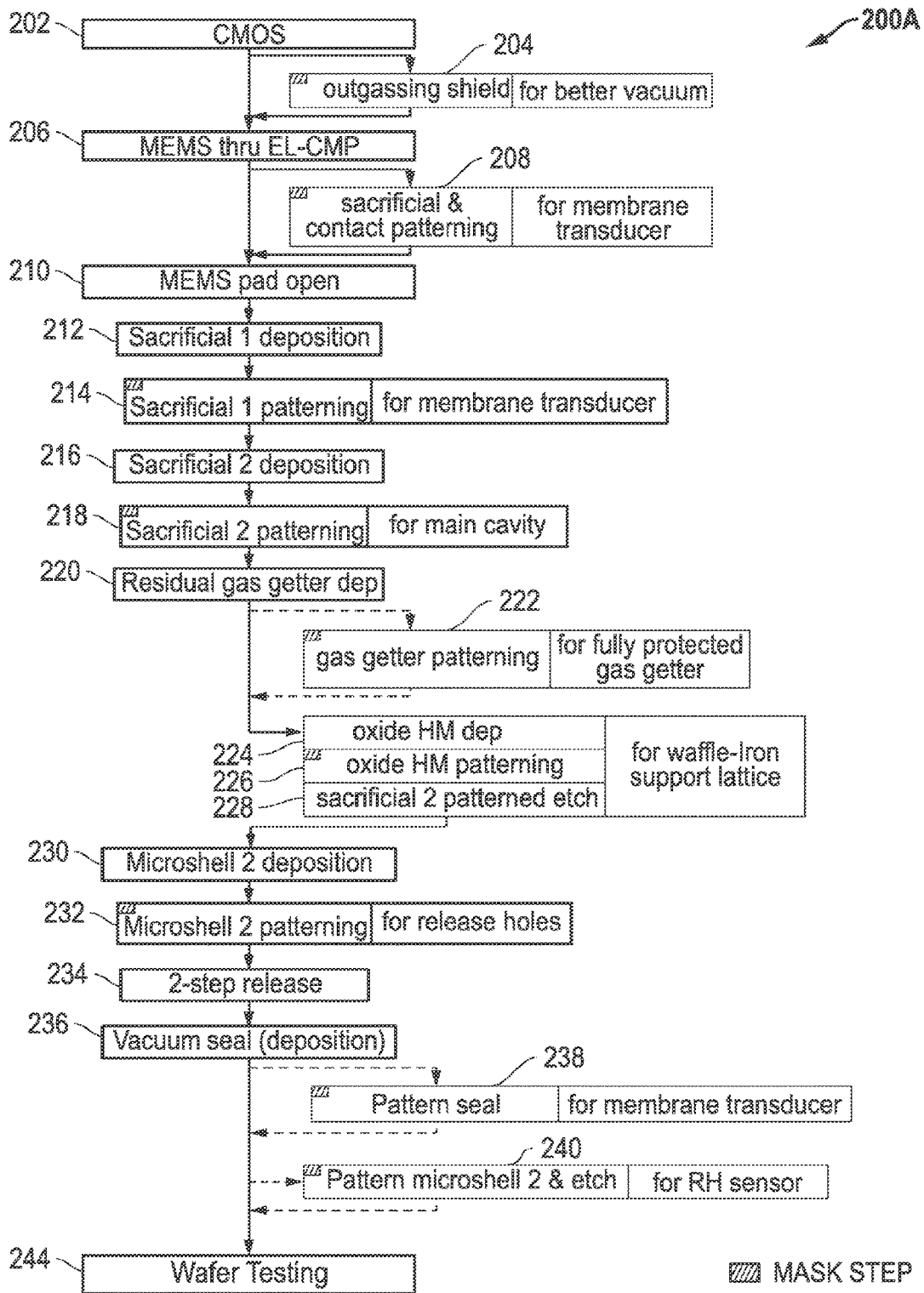

FIG. 2A

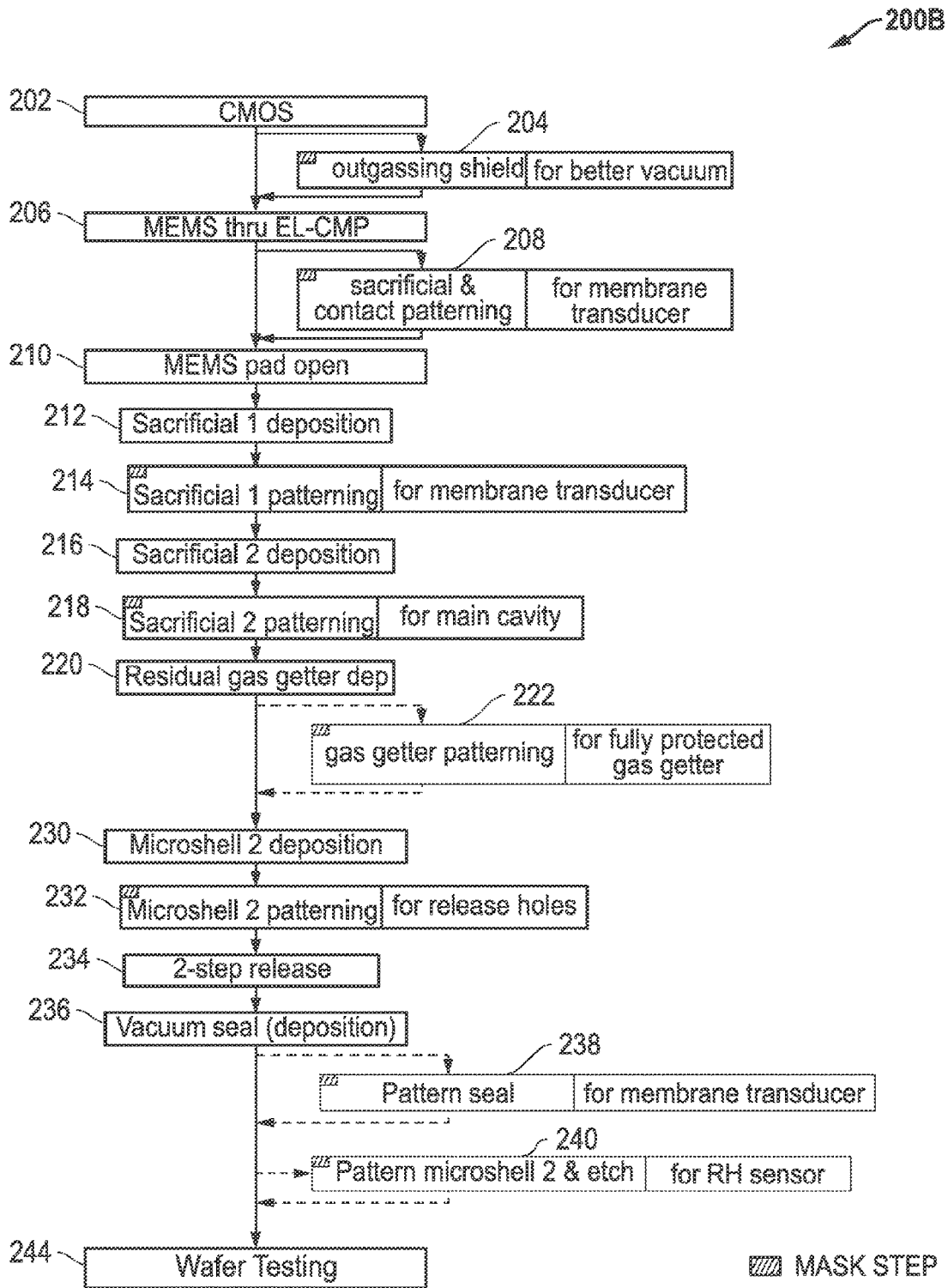

FIG. 2B

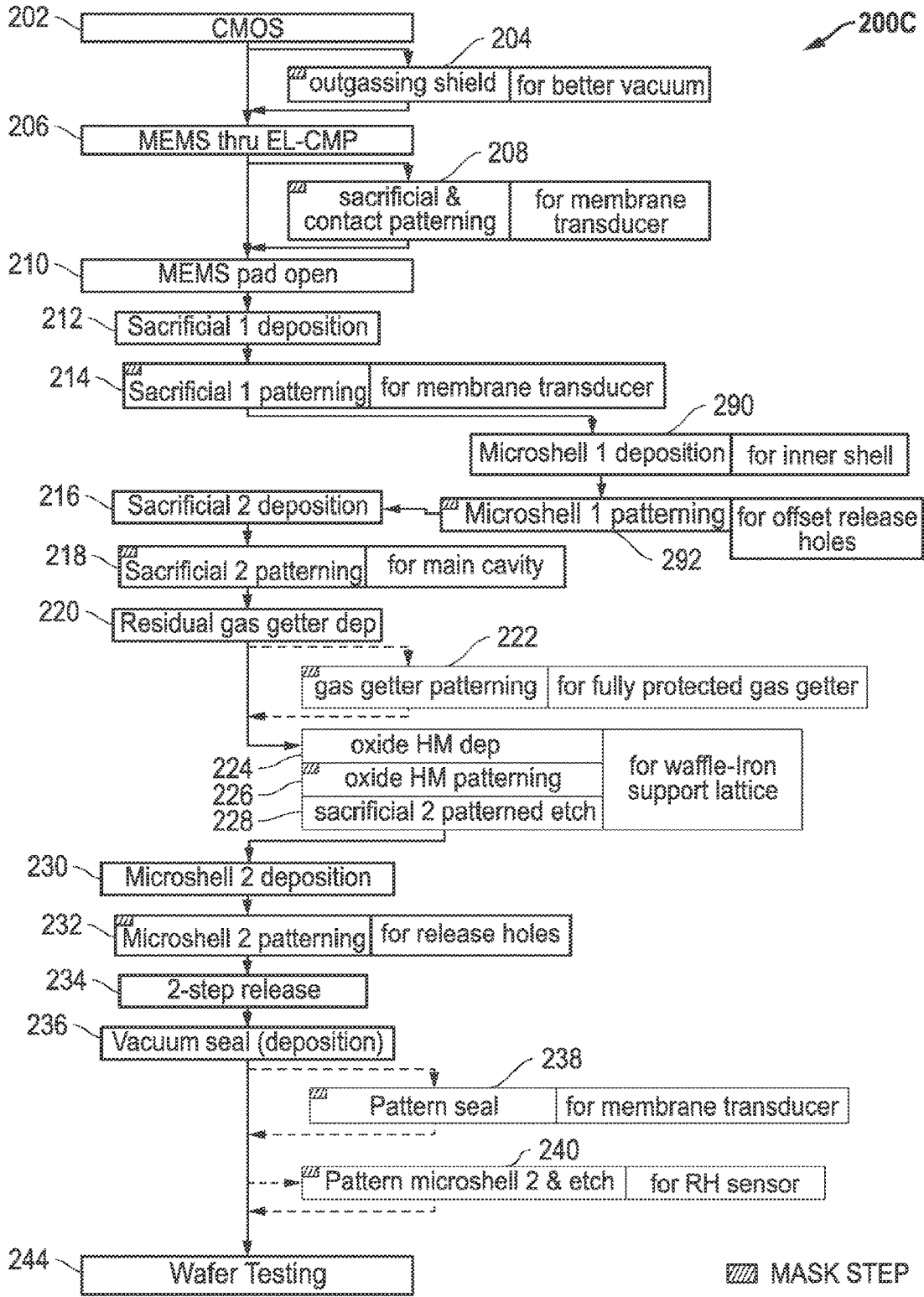

FIG. 2C

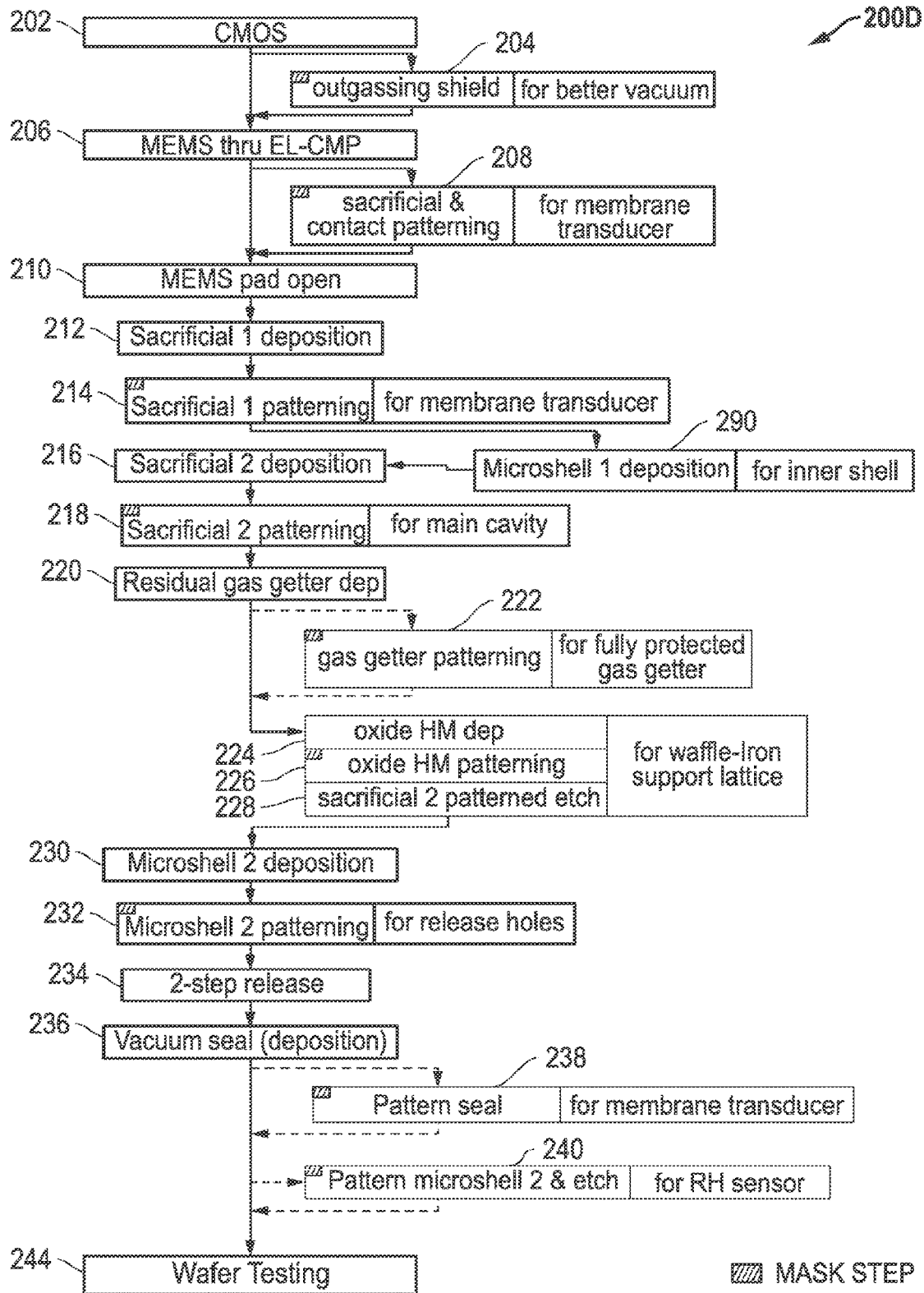

FIG. 2D

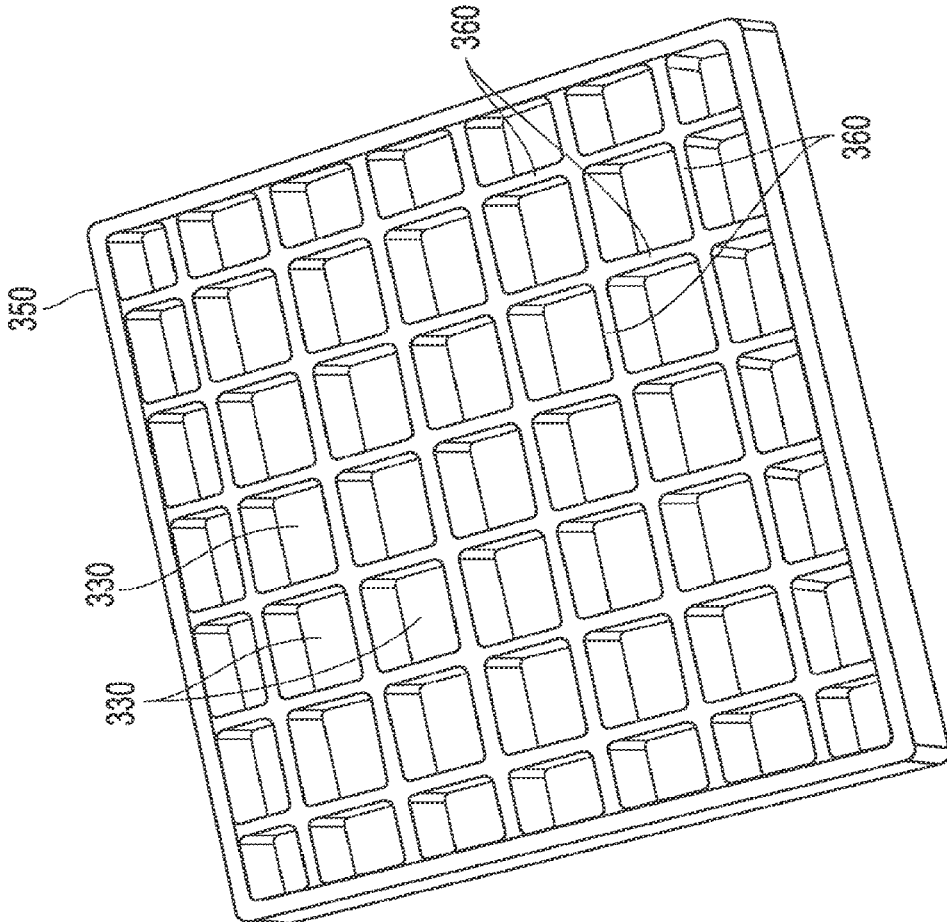

FIG. 4

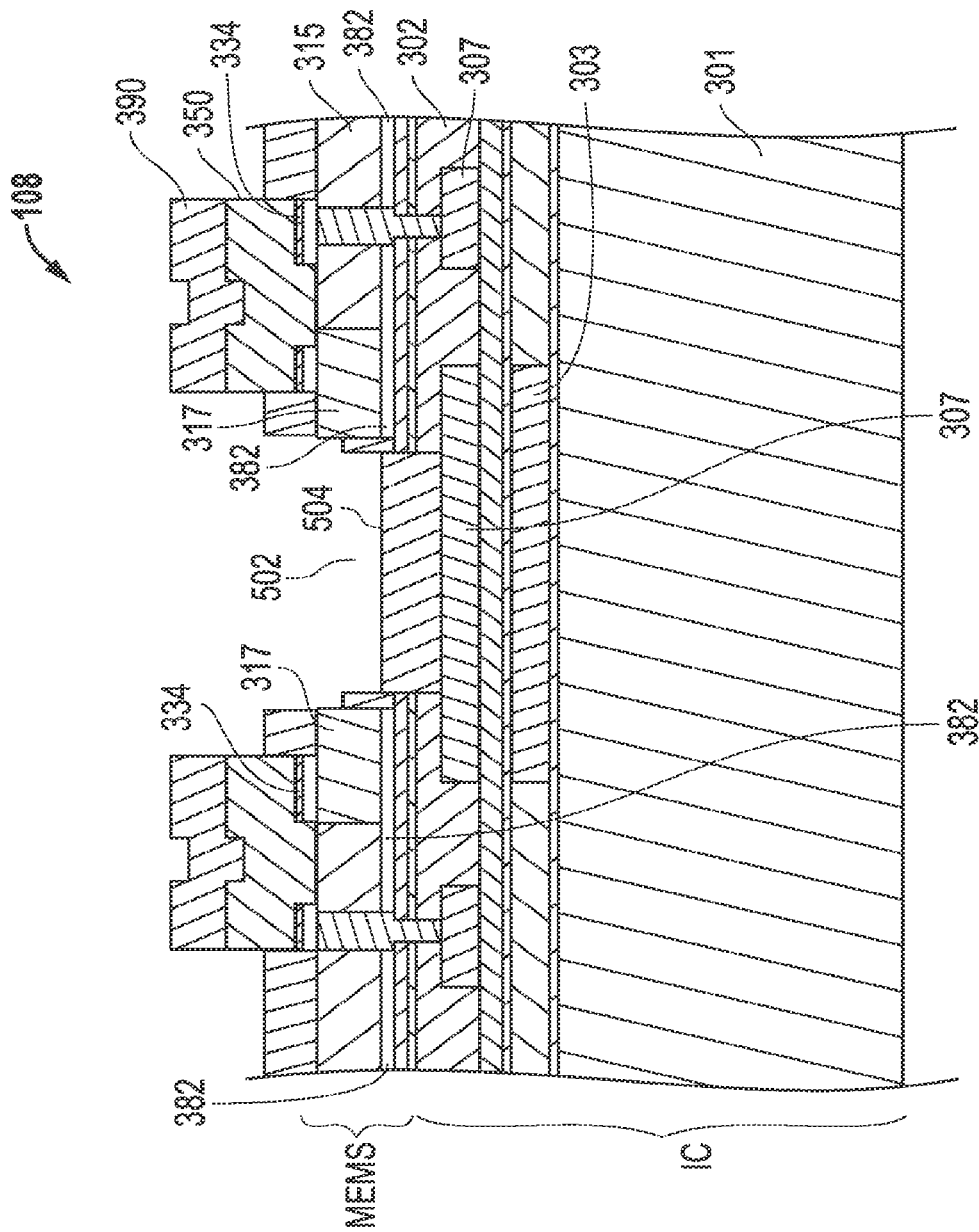

FIG. 5

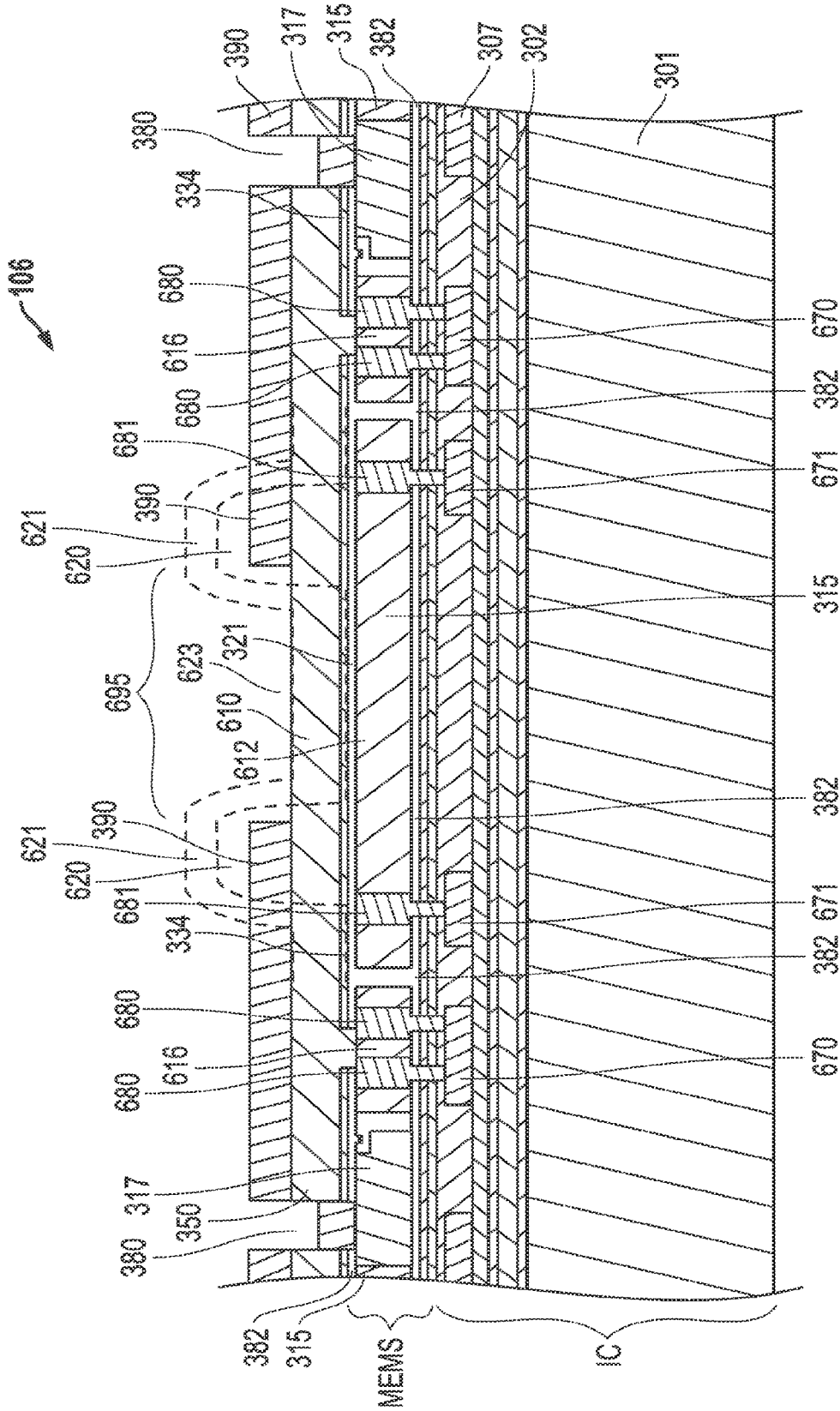

FIG. 6

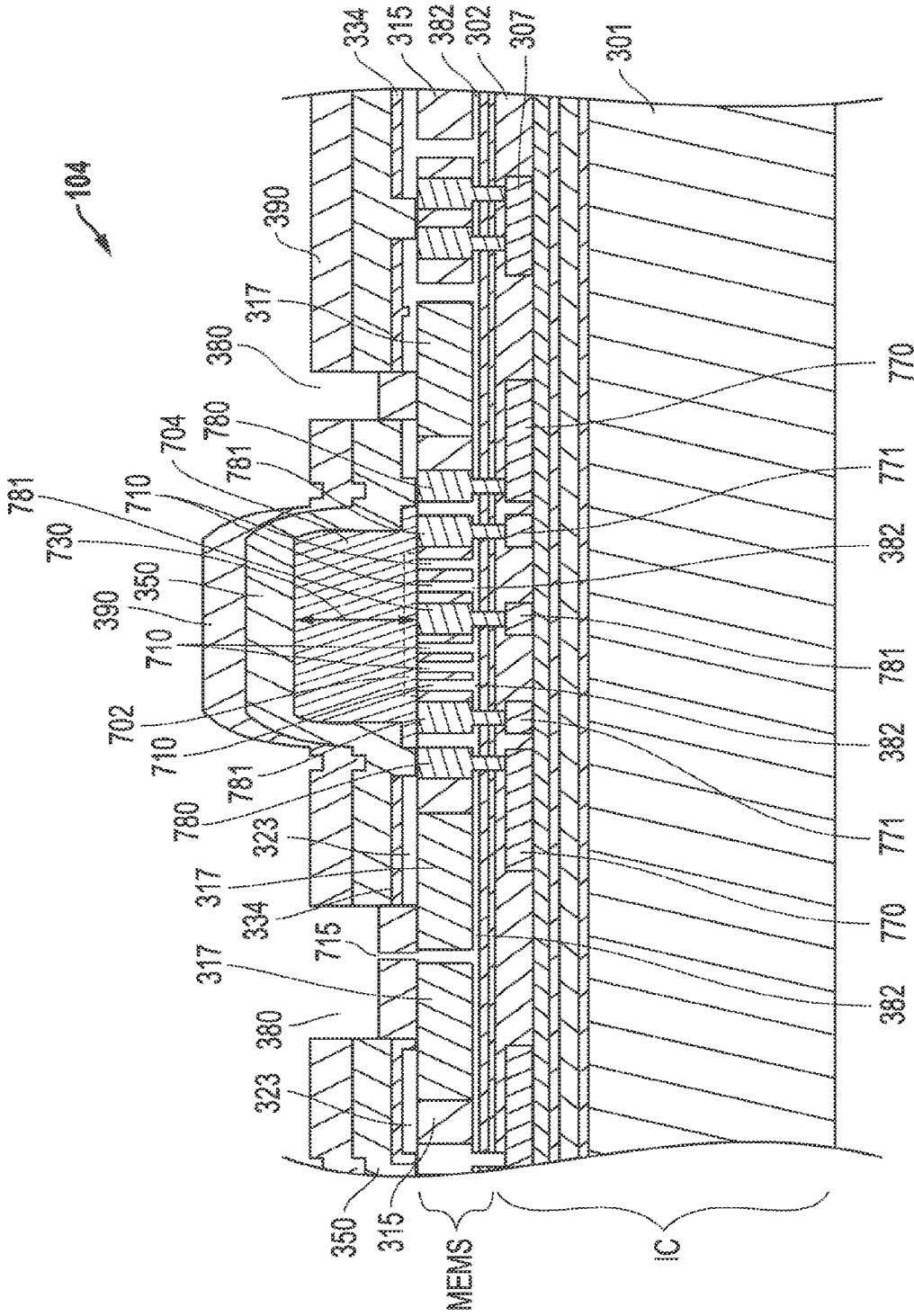

FIG. 7

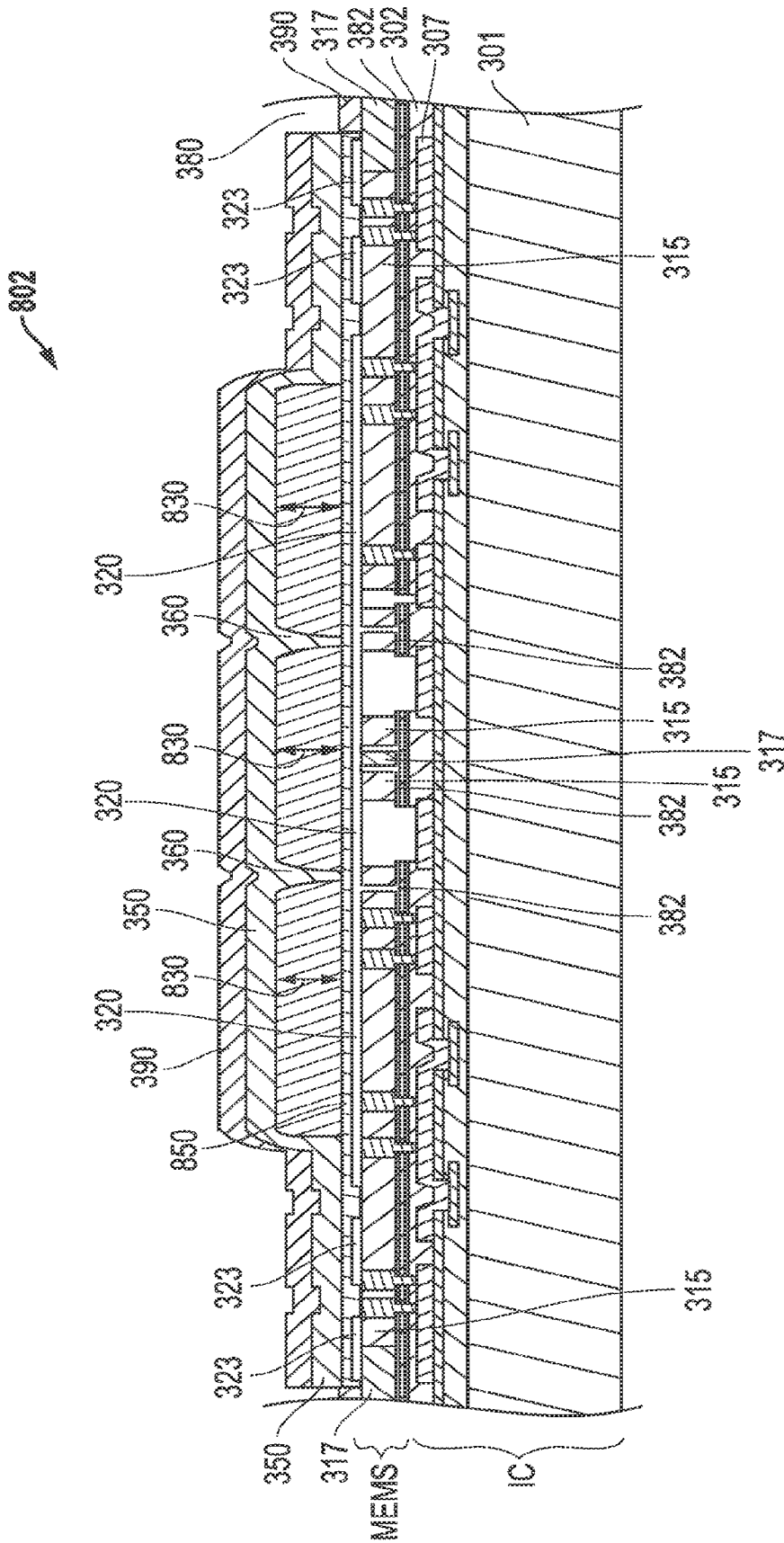
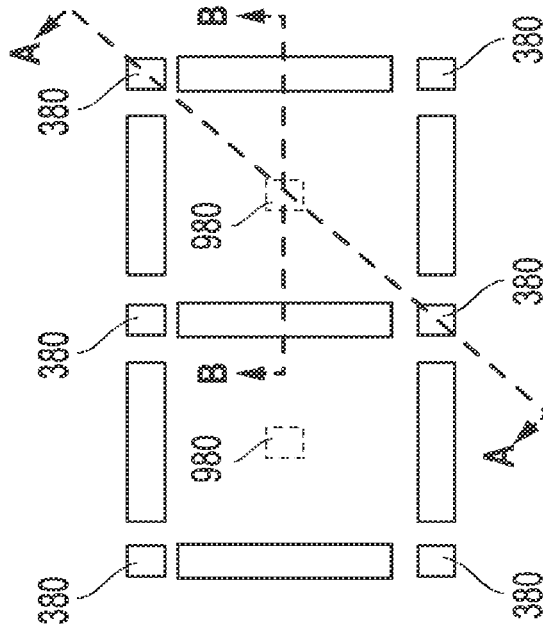
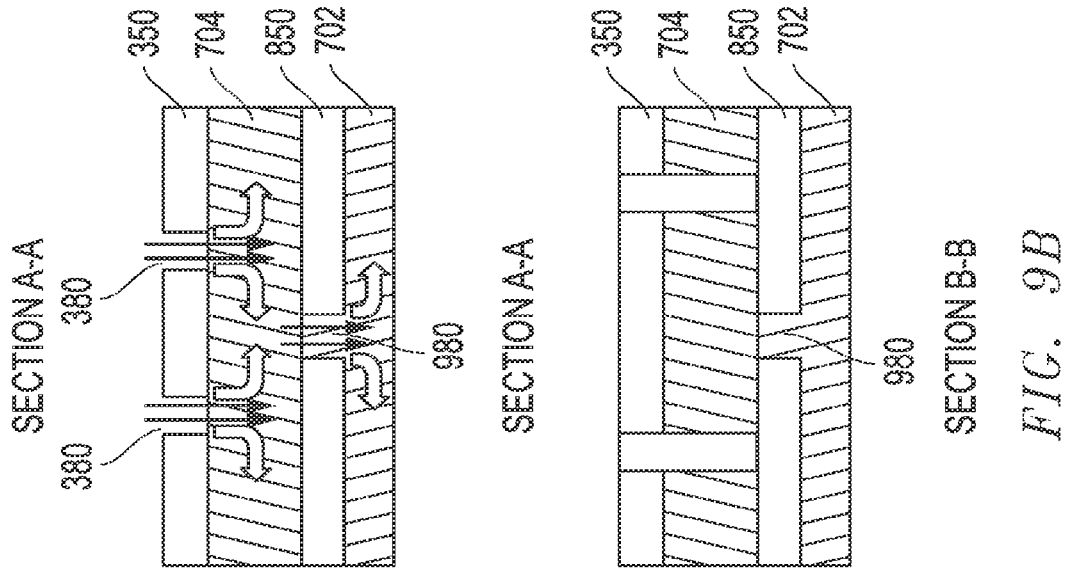

FIG. 8



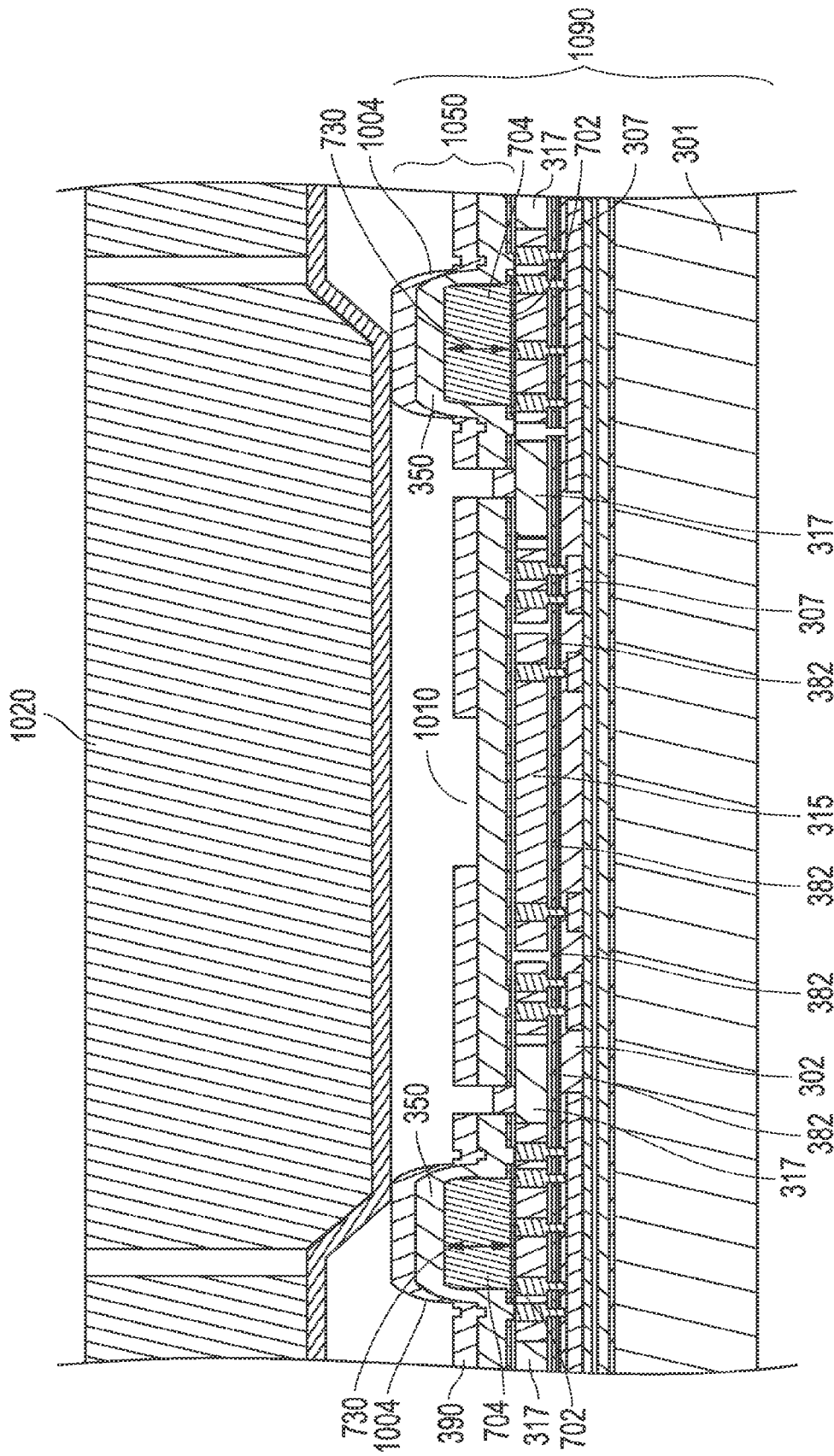

FIG. 10

**METHODS AND STRUCTURES FOR
THIN-FILM ENCAPSULATION AND
CO-INTEGRATION OF SAME WITH
MICROELECTRONIC DEVICES AND
MICROELECTROMECHANICAL SYSTEMS
(MEMS)**

CROSS-REFERENCES TO RELATED
APPLICATIONS

The present application is a divisional application of U.S. patent application Ser. No. 14/532,658, filed Nov. 4, 2014, entitled "Methods and Structures for Thin-Film Encapsulation and Co-Integration of Same with Microelectronics Devices and Microelectromechanical Systems (MEMS)", which claims the benefit of U.S. Provisional Patent Application Ser. No. 62/029,233, filed on Jul. 25, 2014 and entitled "Methods and Structures for Thin-Film Encapsulation and Co-Integration of Same with Microelectronics Devices and Microelectromechanical Systems (MEMS)", each of which is incorporated herein by reference in its entirety for all purposes.

U.S. patent application Ser. No. 14/532,658 is related in subject matter to concurrently-filed patent application Ser. No. 14/532,675 entitled "Membrane Transducer Structures and Methods of Manufacturing Same Using Thin-Film Encapsulation" by Quevy et al., and to concurrently filed patent application Ser. No. 14/532,723 entitled "Trapped Sacrificial Structures and Methods of Manufacturing Same Using Thin-Film Encapsulation" by Quevy et al., each of which is filed on the same date as the present application and each of which is incorporated herein by reference in its entirety.

FIELD OF THE INVENTION

This invention relates generally to semiconductor processing, and more particularly to thin-film encapsulation and co-integration of same with microelectronic devices and microelectromechanical systems (MEMS).

BACKGROUND

The term "MEMS" generally refers to an apparatus incorporating some mechanical structure having a dimensional scale that is comparable to microelectronic devices. Micro-scale fabrication techniques similar to those utilized in the microelectronic industry such as thin film deposition, and thin film patterning by photolithography and reactive ion etching (RIE) form the micromechanical structure in a MEMS.

In the past, multi-layered, planar microshells have been used for encapsulation of devices such as MEMS and microelectronics.

SUMMARY

Disclosed herein are methods and structures for thin-film encapsulation that may be further implemented in one embodiment to co-integrate processes for thin-film encapsulation and formation of microelectronic devices and microelectromechanical systems (MEMS) such as sensors and actuators. In this way, structures having varying characteristics may be fabricated in one embodiment using the same basic process flow by selecting among different process options or modules for use with the basic process flow in order to create the desired structure/s. Embodiments of the

disclosed methods and structures include, among other things, various process flow sequences as well as a variety of device design structures that may be advantageously enabled by the various process flow sequences.

The disclosed methods and structures may be implemented in one embodiment using a process flow that allows thin-film microshell structures to be defined in a manner that addresses challenges typically encountered with implementation of conventional thin microshell structures. In this regard, a process flow may be employed in one exemplary embodiment to form a vacuum cavity under a thin-film microshell structure that has a smaller volume than a conventional wafer-bonded cavity, while at the same time maintaining a level of vacuum within the smaller volume microshell cavity that is equivalent or comparable to the level of vacuum that is typically maintained within a larger volume of a conventional wafer-bonded cavity structure. Such a process flow may also be implemented in one exemplary embodiment to maintain thin-film microshell vacuum cavity yield and robustness against post-encapsulation flows, included wafer processing and packaging flows which for example may exhibit high levels of pressure (e.g., greater than about 10 MPa) during the package molding process. Other advantages over conventional microshell processing that may be realized by one or more embodiments of the disclosed methods and structures include compatibility of integration with higher thermal budget associated with additional post-processing steps, as well as a level of device and product reliability (e.g., including long term stability) when exposed to environmental stresses that is comparable to the device and product reliability that is possible with conventional wafer-bonded cavity structures.

In another embodiment, the disclosed methods and structures may be implemented using a process flow to define thin-film microshell structures in a manner that enables the co-integration and co-location of sensors, actuators and other types of MEMS devices, while at the same time leveraging some of the same process features and structural elements for both microshell and different device structures. In one exemplary embodiment, optional processing modules may be used to strengthen a microshell structure and decouple the function of specific steps. Even when implementation of these optional processing modules results in an increase in the number of process steps and/or patterning masks, it also eases the integration and process requirements (e.g., sidewall profile, CD, wafer uniformity, etc.).

For example, a patterning step on a single layer may be used to provide two functions and have two different specification requirements. Since these specifications might be challenging to achieve with a single patterning step, the two functions may be separated out into different steps that may be independently tuned for the specific purpose, e.g., in some ways similar to a dual damascene process, where the same copper layer is used for both routing and via connections. However, for a microshell structure, it may be possible to achieve both functions with only a single mask/patterning step.

Examples of possible exemplary and optional processing modules include, but are not limited to: formation of a lower (or inner) microshell beneath an upper (or outer) microshell to provide a second layer of support; forming a patterned version of an inner microshell to provide both support and inner release holes for underlying structural devices that are offset from outer release holes formed in an overlying outer microshell (e.g., offset inner release holes may be employed to reduce the restrictions on the outer shell release holes, thus increasing the number of release holes and reducing the

release etch time); completely enclosing a microshell structure getter layer (e.g., such as titanium) in oxide to protect it from attack from a release etchant such as hydrogen peroxide (H₂O₂); use of a hardmask (e.g., SiO₂) for sacrificial patterning that may be used as a mold for creating a waffle-like support lattice to reinforce a microshell structure (e.g., such a hardmask may be added as an independent layer or may leverage the getter multi-layer stack mentioned above).

In one exemplary embodiment, a process flow may be provided that also has the capability of adding different process options so as to enable additional functionalities and capabilities, e.g., including pressure sensors, ultrasonic transducers, relative humidity (RH) sensors, infrared (IR) sensors, optical modulators, etc. Such processing options may be seamlessly inserted (or removed) without significantly impacting the remaining steps. Examples of such process options include, but are not limited to: use of a vertical sacrificial layer for ultrasonic transducers (e.g., a thin sacrificial layer may be placed over an existing structural layer, such as SiGe, to create a small vertical gap to a microshell structure); patterning of a sealing material (e.g., such as a sealing metal) on a microshell structure for pressure sensors, IR bolometers (e.g., the metal layer used to seal the microshell may be patterned to allow for IR transmission and/or to control mechanical properties of the membrane); polyimide or other sacrificial layer patterning for relative humidity sensors (e.g., polyimide may be deposited and patterned to create a relative humidity sensor, or alternatively an existing polyimide sacrificial layer may be preserved and not removed in the sacrificial etch, so that it may be exposed at this step).

In one respect, disclosed herein is a method of forming a microshell structure, including: forming a first sacrificial layer over a MEMS region and an underlying substrate, and removing a part of the first sacrificial layer to leave one or more remaining portions of the first sacrificial layer; forming a second sacrificial layer over the remaining portions of the first sacrificial layer, and removing a part of the second sacrificial layer to leave one or more remaining portions of the second sacrificial layer over at least a part of the remaining portions of the first sacrificial layer; forming an upper microshell layer over the remaining portions of the first and second sacrificial layers; creating one or more upper release holes in the upper microshell layer; removing at least a part of the remaining portions of the first and/or second sacrificial layers through the upper release holes to form one or more open cavities or open areas under the upper microshell layer; and forming a sealing layer on the upper microshell layer to seal the upper release holes in the upper microshell layer.

In another respect, disclosed herein is a microshell structure, including: a lower microshell layer disposed over a MEMS region and an underlying substrate; one or more lower release holes defined in the lower microshell layer; an upper microshell layer disposed over the lower microshell layer; one or more upper release holes defined in the upper microshell layer; one or more open cavities or open areas defined under the upper microshell layer; and a sealing layer disposed on the upper microshell layer that seals the upper release holes in the upper microshell layer.

In another respect, disclosed herein is a microshell structure, including: an upper microshell layer disposed over a MEMS region and an underlying substrate; at least one open cavity defined under the upper microshell layer; and one or more microshell support lattice members that extend down-

ward from the underside of the upper micro shell layer into the open cavity defined under the upper microshell layer.

In another respect, disclosed herein is a microshell structure, including: an upper microshell layer disposed over a MEMS region and an underlying substrate, the MEMS region including a metallization layer overlain by an electrically insulative material layer and a MEMS structural layer above the electrically insulative material layer, and a pad region with a pad opening to the metallization layer through the MEMS structural layer and the electrically insulative material; at least one open cavity defined under the upper microshell layer; one or more upper release holes defined in the upper microshell layer; an opening defined through the upper microshell layer over the pad region to the MEMS metallization layer; and an electrically conductive sealing layer disposed on the upper microshell layer that seals the upper release holes in the upper microshell layer, the electrically conductive sealing layer contacting the metallization layer of the MEMS region through the pad opening to form a shadow mask conductive electrical pad.

BRIEF DESCRIPTION OF THE DRAWINGS

FIG. 1 illustrates a simplified cross-sectional view of different exemplary structures and devices that may be fabricated according to various embodiments of the disclosed systems and methods

FIG. 2A illustrates a fabrication process flow according to one exemplary embodiment of the disclosed methods and structures.

FIG. 2B illustrates a fabrication process flow according to one exemplary embodiment of the disclosed methods and structures.

FIG. 2C illustrates a fabrication process flow according to one exemplary embodiment of the disclosed methods and structures.

FIG. 2D illustrates a fabrication process flow according to one exemplary embodiment of the disclosed methods and structures.

FIG. 3 illustrates a cross-sectional view of a vacuum encapsulated device structure according to one exemplary embodiment of the disclosed methods and structures.

FIG. 4 illustrates a perspective view of the underside of an upper microshell layer structure according to one exemplary embodiment of the disclosed methods and structures.

FIG. 5 illustrates a cross-sectional view of a shadow mask pad structure according to one exemplary embodiment of the disclosed methods and structures.

FIG. 6 illustrates a cross-sectional view of a membrane transducer structure according to one exemplary embodiment of the disclosed methods and structures.

FIG. 7 illustrates a cross-sectional view of a trapped sacrificial structure according to one exemplary embodiment of the disclosed methods and structures.

FIG. 8 illustrates a cross-sectional view of a vacuum encapsulated device structure according to one exemplary embodiment of the disclosed methods and structures.

FIG. 9A illustrates an overhead view showing a pattern of offset microshell release holes according to one exemplary embodiment of the disclosed methods and structures.

FIG. 9B illustrates cross-sectional views of offset microshell release holes according to one exemplary embodiment of the disclosed methods and structures.

FIG. 10 illustrates a cross-sectional view showing the interaction between a molding tool and a spacer structure according to one exemplary embodiment of the disclosed methods and structures.

DESCRIPTION OF ILLUSTRATIVE EMBODIMENTS

FIG. 1 illustrates a simplified cross-sectional view of some of the different exemplary structures and devices that may be fabricated, alone or together, on a common die substrate **301** by selecting and using various processing options of the same basic process flow according to the disclosed systems and methods. In particular, FIG. 1 illustrates a vacuum encapsulated device structure **102** that includes a single structural layer microshell, a trapped sacrificial structure **104** (e.g., for a relative humidity sensor), a membrane transducer structure **106**, and a shadow mask pad structure **108**. As will be described further herein, one or more of these and/or other exemplary structures may be simultaneously fabricated (e.g., on a common substrate **301**) using common processing features of a process flow and/or common structural elements. In this embodiment, whether or not optional layers are used, a process flow may be provided that allows co-location of different types of device structures as illustrated in FIG. 1. FIGS. 2A-2D illustrate the modular aspect of the disclosed process flows and the tradeoff between complexity and flexibility that may be made by choosing between the different process flows. It will be understood that in one embodiment, vacuum encapsulation is not necessary for any one or more of the above structures.

It will be understood that the particular illustrated process flows of FIGS. 2A-2D are exemplary only, and that other combinations of fewer, additional, and/or alternative process steps may be employed. It will further be understood that each of the process flows of FIGS. 2A-2D may be varied to accommodate a number of materials for each process step. Relative complexity of the process flow embodiments of FIGS. 2A-2D may be ordered as follows (from most complex and most design flexibility to least complex and least design flexibility): FIG. 2C (most complex and most design flexibility)>FIG. 2D>FIG. 2A>FIG. 2B (least complex and least design flexibility).

With regard to the following description of process flows of FIGS. 2A-2D, Table 1 lists some of the exemplary materials and alternative materials that may be employed for some of the different layers described below to achieve the structures disclosed herein.

TABLE 1

Layer	Exemplary Material Selection	Examples of Other Exemplary Alternatives
Sacrificial 1 layer for CMUT vertical gap (321)	Ge	Amorphous Carbon (a-C)
Sacrificial 1 layer (702)	Polyimide	Ge, oxide, a-C
Microshell 1 layer (850)	SiGe	Oxide, nitride, TiAl, Ge, multi-layer (metal stack)
Sacrificial 2 layer (704)	Polyimide	Ge, oxide, a-C
Getter layer (334)	Ti	V, Zr, Ba
Microshell 2 layer (350)	SiGe	nitride, TiAl, W
Vacuum seal layer (390)	Al	PVD materials (SiGe, other metals)

FIG. 2A illustrates one exemplary embodiment of process flow **200A** for forming a single structural layer microshell with a relatively thin but rigid underlying cavity such as illustrated by the vacuum encapsulated device structure **102** of FIG. 1. In the embodiment of FIG. 2A, steps **202** through **210** may be employed to form underlying integrated circuit ("IC") and MEMS regions of the structure of FIG. 1, e.g., using methodology such as described and illustrated in U.S.

Pat. No. 7,923,790, which is incorporated herein by reference in its entirety for all purposes. In this regard, MEMS and IC portions may be completed using commonly known techniques, such as, but not limited to chemical vapor deposition (CVD), physical vapor deposition (PVD), electroplating, chemical mechanical planarization (CMP), patterned and unpatterned etching by wet chemicals or by reactive ion etching (RIE) plasmas. For example, FIG. 3 illustrates IC and MEMS regions formed according to one exemplary embodiment of steps **202-210**. However, it will be understood that the disclosed methods and structures may be implemented for a variety of MEMS and microelectronics devices, and thus the formation of the MEMS and IC regions may vary substantially and therefore may deviate significantly from that depicted in FIG. 3.

In the exemplary embodiment of FIG. 3, formation of the IC portion or regions may include the deposition of inter-layer dielectric (ILD) **302** over substrate **301** by CVD and deposition of metallizations **303** and **307**, e.g., by PVD or electroplating over substrate **301**. Metallizations **303** and **307** may be patterned lithographically and subsequently etched or metallizations **303** and **307** may be deposited in pre-formed trenches in ILD **302** and subsequently delineated with chemical mechanical polishing (CMP) as in a common damascene metal interconnect process. Insulative layer or dielectric passivation layer **305** may be formed between metallizations **303** and **307**, e.g., by chemical vapor deposition (CVD) followed by chemical mechanical polishing (CMP) to planarize. These illustrated layers represent the structures that may be found in one exemplary embodiment in a microelectronics IC region, it being understood that other IC region embodiments are possible. In one embodiment, the IC region may rely on any commonly known microelectronic transistor technology, such as, but not limited to MOSFET and bipolar junction transistors (BJT). In the practice of the disclosed system and methods it will be understood that devices and other structures (e.g., such as various MEMS devices and structures **102**, **104**, **106** and **108**) may be integrated with an IC region as shown, or in an alternate embodiment may be present as discrete MEMS devices and other structures over a substrate **301**.

Substrate **301** may be any commonly known semiconductor substrate, such as, but not limited to, single crystalline silicon, germanium or a silicon/germanium layer doped with an appropriate charge carrier. Substrate **301** may alternatively be comprised of a III-V material such as but not limited to gallium nitride, gallium phosphide, gallium arsenide, indium phosphide or indium antimonide. Moreover, substrate **301** may comprise an insulating layer such as silicon dioxide or silicon nitride embedded below a monocrystalline semiconductor layer to form, for example, a silicon on insulator or germanium on insulator substrate. Bulk insulators, such as sapphire, quartz, and glass may also be used.

Still referring to the exemplary embodiment of FIG. 3, a MEMS structural layer **315** may then be formed in one exemplary embodiment over the IC portion, e.g., using a damascene process. In general terms, a release layer (not shown) may be deposited, planarized, and etched with a desired pattern, e.g., to form blades or posts or other suitable or desired features. In a particular embodiment, such a release layer may be germanium deposited at a temperature of approximately 350° C. using a low pressure (LP) CVD process. Following the formation of the release layer, a MEMS structural layer **315** may then be deposited over the release layer and planarized to expose the blades, posts or other features of the release layer and thereby separate the

structural layer into different segments. In a further embodiment, a dielectric material **317** such as polyimide or other suitable dielectric material such as described herein may be optionally deposited, patterned and etched prior to deposition of MEMS structural layer **315**, e.g., to form selected areas of dielectric material **317** within MEMS structural layer **315** as illustrated herein. When present, such an optional dielectric material **317** may be selected to have selective sacrificial and etchant material properties relative to other layers as may be needed for a given application, such as for use in the area of release holes **380** and inlets **715** described further herein. In a particular embodiment employing a germanium release layer, MEMS structural layer **315** may be an alloy of silicon and germanium deposited at a temperature of approximately 425° C. using an LPCVD process. After fabricating the IC and MEMS regions, the thin-film encapsulation fabrication processes described further herein may be used to form microshell and/or device structures which may be incorporated at virtually any back end of line (BEOL) level of the typical IC fabrication process.

Returning to FIG. 2A, in step **212** a relatively thin first sacrificial layer may be deposited over MEMS structural layer **315** and then patterned and etched in step **214** to remove all but selected portions of the deposited first sacrificial layer to create a mold that will ultimately result in first cavity portion **320** (e.g., including peripheral open areas **320**) and other open areas **323** when the first sacrificial layer is later removed as shown in FIG. 3. The first sacrificial layer may also be patterned and etched in step **212** to form other features in selected areas of the first sacrificial layer to be used for forming desired devices, e.g., such as a membrane transducer described later herein. In one exemplary embodiment, thickness of first sacrificial layer may be from about 0.5 μm to about 1 μm, although first sacrificial layer thicknesses of less than 0.5 μm and greater than 1 μm are also possible.

Next, in step **216**, a relatively thicker second sacrificial layer may be deposited on top of the first sacrificial layer, and then patterned and etched in step **218**, e.g., to create the mold for second thicker cavity portions **324**. In one exemplary embodiment, thickness of the second sacrificial layer may be from about 5 μm to about 20 μm and alternatively from about 5 μm to about 15 μm, although first sacrificial layer thicknesses of less than 5 μm and greater than 20 μm are also possible. As will be further described, both first and second sacrificial layers may be subsequently removed to result in main cavity sections **330** of the exemplary embodiment of FIG. 3. In this regard, the dashed line extending across main cavity sections **330** in FIG. 3 serves to delineate the interface between the first and second sacrificial layers after second sacrificial layer deposition in step **218** prior to removal of the first and second sacrificial layers and deposition of an upper microshell layer **350** as described further herein. In one exemplary embodiment, multiple sacrificial layers may be deposited and removed to form a larger main cavity section **330** that maximizes cavity volume so as to better maintain vacuum and allow more room for the completed microshell structure to flex.

In one exemplary embodiment, the first cavity portions **320** and second cavity portions **324** may be formed to result in a multi-level cavity that enables different functionality of the upper microshell layer **350** to be created at different locations across the substrate **301**, e.g., the thinner, first cavity portions **320** under microshell layer **350** may be used in one embodiment as a CMUT gap **321** for a membrane transducer **106** such as pressure sensor or other type trans-

ducer, and the main cavity sections **330** (i.e., including combined areas of first and second cavity portions **320** and **324**) may be used for vacuum encapsulation for a vacuum encapsulated device structure **102**, such as a MEMS resonator formed in MEMS structural layer **315**.

To achieve the structure illustrated in FIG. 3, the first and second sacrificial layers may be of any suitable materials. For example, in one exemplary embodiment the first sacrificial layer may be deposited in step **212** as any one or more of polyimide, oxide, germanium, amorphous carbon, or other suitable sacrificial material, and then selectively etched after masking in step **214** using lithography and/or reactive ion etching (REI) to leave selected portions of the first sacrificial layer in areas corresponding to later-formed open areas **320** and **323** as previously described. The second sacrificial layer may then be deposited in this exemplary embodiment in step **216** as any one or more of polyimide, oxide, germanium, amorphous carbon, or other suitable sacrificial material, and then then selectively etched after masking in step **218** using lithography and/or REI to leave portions of the second sacrificial material corresponding to the main cavity sections **330** on top of the previously patterned first sacrificial layer portions of areas **320**, as well as to leave first sacrificial layer portions of areas **323**, which each are selectively not removed in step **218**. It is noted that selection of sacrificial material for each of first and second sacrificial layers may be made, among other things, based on at least two factors: dimensioning limits (e.g., thickness, critical dimension “CD”, etc.) and material compatibility with other processes (e.g., processing temperature, glass transition temperature, decomposition temperature, etc.)

Next, in step **220**, an optional residual gas getter layer **334** may be deposited (e.g., to a thickness of from about 0.1 μm to about 1 μm (alternatively about 0.3 μm) or any other suitable greater or lesser thickness) on top of the patterned first and second sacrificial layers in order to scavenge or otherwise remove contaminants from open areas **320**, **323** and main cavity sections **330**, including contaminants left behind from the etch of the first and/or second sacrificial layers after their removal, contaminants emitted by materials of the microshell layer **350**, etc. In this regard, getter layer **334** may be configured to capture molecules, such as hydrogen, nitrogen, oxygen, water vapor, oxides of carbon, methane, etc. from within sections of areas **320**, **323** and **330** after removal of first and second sacrificial layers. Examples of suitable materials for use as getter layer **334** include, but are not limited to, titanium, aluminum, vanadium, zirconium, barium-based compounds, etc. An optional oxide-based protective layer may be formed on the cavity-side surface of the getter layer **334** to prevent sacrificial etchants from prematurely damaging the getter layer **334** during patterning. In one embodiment, such protective layer may be an oxide of silicon of silicon, such as silicon dioxide (SiO₂), or other material that provides good selectivity to etchants of the first and second sacrificial layers. For example, a protective oxide layer has good selectivity to oxygen plasma that may be employed for etching polyimide or amorphous carbon sacrificial layers, polyimide has good selectivity to vapor HF or liquid HF etchants that may be employed for etching silicon dioxide sacrificial layers, and many protective materials have good selectivity to peroxide that may be employed for etching germanium sacrificial layers, etc. Further information on getter layer configuration and materials for protecting getter layers may be found in U.S. Pat. No. 7,923,790, which is incorporated herein by reference in its entirety.

In step **222**, deposited getter layer **334** may be optionally masked and patterned by reactive ion etching (RIE), ion

milling, lift off, or any of a variety of other etching or patterning techniques for purposes of limiting the extent of getter layer 334 to areas of first cavity 320 and second cavity 324, and/or to prevent electrical coupling of getter layer 334 with underlying devices formed on or in MEMS region/ structural layer 315 (e.g., such as inductors).

After optional deposition and patterning of gas getter layer 334, an oxide hard mask layer (e.g., SiO₂ or other suitable hard mask material) may be deposited in step 224 (e.g., by plasma enhanced chemical vapor deposition) and then patterned (e.g., by photolithography and resist) in step 226 to create a hard mask used to etch a mold into the second sacrificial layer in step 228 for forming microshell support lattice members 360 upon later deposition of upper microshell layer 350 as further illustrated and described with regard to FIG. 4.

Next, an upper microshell layer is deposited in step 230 over the first and second sacrificial layers and the getter layer 334 to create an upper microshell layer structure 350 as illustrated in FIG. 3. The upper microshell layer may in one embodiment be a silicon germanium (SiGe) material layer that is deposited by a low-pressure chemical vapor deposition (LPCVD) or plasma-enhanced chemical vapor deposition (PECVD) process to a thickness of from about 1 μm to about 2 μm at locations other than at support lattice members 360 which are described further below. However, it will be understood that any other suitable material suitable for forming an upper microshell layer having the desired characteristics for a given application may alternatively be formed over the first and second sacrificial layers. Examples of such microshell layer characteristics include, but are not limited to, relatively low processing thermal budget, hermeticity of formed microshell layer, conductivity of microshell layer for transducer applications or to provide a Faraday cage to isolate underlying devices from electromagnetic interference, transparency to one or more radiation wavelengths such as infrared radiation for underlying sensors, etc. Specific examples of other suitable types of upper microshell materials include, but are not limited to, nitride, titanium aluminide (TiAl), tungsten, etc. Moreover, thickness of upper microshell layer 350 may vary according to the needs of a given application, e.g., formed to be greater than 2 μm or less than 1 μm in other possible embodiments.

FIG. 4 illustrates a perspective view of one embodiment of the underside (e.g., interior cavity side) of an upper microshell layer structure 350 as it may be formed to include microshell support lattice members 360 using steps 224 to 228 previously described. In the illustrated embodiment microshell support lattice members 360 have been formed to create an array of square or rectangle cavity sections 330 after removal of the second sacrificial layer from these sections. However, it will be understood that any other configuration of support lattice members may be formed that are suitable for creating other cavity section shapes that are adequate to optimize robustness, stiffness, surface to volume ratio and/or manufacturability. Examples of other such cavity section shapes include, but are not limited to, hexagonal, triangular, disk-shaped, octagonal, etc. As may be seen in FIG. 3, the second sacrificial layer may be patterned to result in a deposited microshell layer 350 having support lattice members 360 that terminate above (and do not contact) MEMS structural layer 315. Rather, the second sacrificial layer may be patterned such that the deposited microshell layer 350 contacts MEMS structural layer 315 at the peripheral edges around cavity sections 330 to suspend the microshell layer 350 and its lattice members 360 over interior cavity sections 330.

In one exemplary embodiment, a second sacrificial layer having a thickness of from about 5 μm to about 20 μm may be deposited at relatively low temperature, and patterned to allow a relatively thin microshell layer 350 to be deposited over the sacrificial layer having a thickness of from about 1 μm to about 2 μm at locations of the layer 350 between the downwardly suspended lattice members 360. Due to the relatively larger thickness of the second sacrificial layer, the second sacrificial layer may be patterned to result in a relatively thicker layer of material 350 at the location of the support lattice members 360 as shown. Thus, in one exemplary embodiment, the microshell layer 350 may be formed with support lattice members 360 having a thickness that is just less than or equal to the overall thickness of the second sacrificial layer before etching (e.g., from less than or equal to about 5 μm to less than or equal to about 20 μm). In one exemplary embodiment, a gap between the base of support lattice members 360 and top of structural layer 315 that is equal to the thickness of the first sacrificial layer, e.g., from about 0.5 μm to about 1 μm. In one embodiment, width (horizontal side-to-side) of individual support lattice members 360 may be less than about twice the thickness of microshell layer 350 as it is measured between the support lattice members 360.

Advantageously, support lattice members 360 may be provided in one exemplary embodiment to strengthen a relatively thin (e.g., about 1 μm to about 2 μm) overlying microshell layer 350 and, in one embodiment, to impart a strength to such an overlying thin microshell layer 350 that is substantially the same as the strength of a relatively thicker microshell layer that has an overall shell thickness that is equivalent to the thickness of the support lattice members 360. In one embodiment, spacing between adjacent individual lattice members 360 may be selected to provide sufficient strength against downward compressional force to meet the needs of given applications, e.g., so as to resist or substantially prevent deflection of microshell layer 350 toward underlying structural layer 315 under anticipated compressional forces for a given application, or so as to limit deflection of microshell layer 350 toward underlying structural layer 315 to a pre-determined amount under anticipated compressional forces of a given application.

Moreover, deposition of a thicker second sacrificial layer may be carried out at relatively lower temperatures than deposition of a thicker microshell layer, and deposition of a thinner microshell layer 350 may be carried out using elevated temperatures for a shorter duration of time than required for deposition of a thicker microshell layer, the latter of which may be incompatible with thermal budget of the process flow and/or more costly. Thus, a relatively thin microshell layer 350 having a relatively lower thermal budget (i.e., shorter microshell deposition time at elevated temperature) may be fabricated with support lattice members 360 to have substantially the same strength as a thicker microshell layer that requires a higher thermal budget (i.e., greater microshell deposition time at elevated temperature). Moreover, in transducer sensor embodiments, a relatively thin overlying upper microshell layer 350 allows for improved sensor sensitivity while the support lattice members 360 allow relatively large volume main cavity sections 330 to be formed under the thin microshell layer structure 350, which provide for greater sensor robustness (e.g., increased vacuum stability against environmental effects) due to increased volume allocated for vacuum space in main cavity sections 330.

Deposited upper microshell layer 350 may then be masked and patterned by etching in step 232 to create release

holes **380** as shown in FIG. **3**, followed by a two-step release process in step **234**. In particular, step **234** may include performance of a first etch step process to remove both first and second sacrificial layers to create first cavity portions **320**, open areas **323**, and main cavity sections **330** shown in FIG. **3**. Step **234** may also include a second etch step (e.g., using hydrogen peroxide) to remove existing sacrificial germanium MEMS release layer in areas **382** of the MEMS region of structure **102**, e.g., beneath selected areas of MEMS structural layer **315** to release MEMS devices formed therein. At the end of this second step release etch, an optional hydrogen fluoride etch may be performed to remove any oxide-based protective layer that has been formed over residual gas getter layer **334** to expose interior surfaces of getter layer **334** so that it may contact and scavenge or otherwise remove contaminants from open areas **320**, **323** and main cavity sections **330**.

Following step **234**, the now empty microshell cavity sections **330** may then be vacuum sealed in step **236** with a hermetic sealing layer **390**. In one embodiment, sealing layer **390** may be comprised of any material or combination of materials suitable for providing hermeticity and that is also compatible with low temperature BEOL IC processing. Examples of suitable materials for forming sealing layer **390** include, but are not limited to, metals such as aluminum, tungsten, copper, titanium, and their alloys. In one exemplary embodiment, sealing layer **390** may be a metal layer that is formed in a vacuum environment using a metal physical vapor deposition tool. Alternative or additional materials that may be employed for sealing layer **390** include non-metals such as SiGe, etc. Moreover, a sealing layer **390** may also comprise multiple metal and/or non-metal layers of different materials. In one embodiment, layer **390** may be an uppermost level of interconnect forming pad structures and/or edge seals, etc. that are typical of an IC (for example metal level nine of a nine level metal BEOL IC process).

In any case, sealing layer **390** (e.g., aluminum or other suitable metal/s) may be formed to seal the release holes **380** in the microshell, trapping the existing process vacuum level in the cavity sections **330**, e.g., above MEMS device/s formed in the underlying MEMS structural layer **315**. This is illustrated in FIG. **3** where release hole **380** is shown filled with sealing layer **390**. In one exemplary embodiment, design and layout may be further selected such that the metal deposition of layer **390** also serves to self-align into pad regions, thus connecting the electrical pads without requiring additional masking step/s as illustrated by pad structure **108**, which is illustrated in further detail in relation to FIG. **5**.

As shown in FIG. **5**, pad structure **108** includes a conductive pad **504** that has been formed by shadow mask deposition of conductive sealing layer/s **390** within pad region **502**. In this case, the underlying opening of pad region **502** down to metallization layer **307** may be previously formed by MEMS sacrificial and contact patterning step **208**, MEMS pad open step **210**, and subsequent sacrificial and microshell patterning steps **214**, **218** and **232**. Thus, self-aligned conductive pad **504** may be then formed by shadow mask deposition of conductive sealing layer **390** after microshell patterning step **232** and release step **234** to connect the electrical pads without the need for additional mask or patterning steps.

When forming vacuum encapsulated device structure **102**, process flow **200A** may proceed directly to step **244** where wafer level testing may be performed. However, one or more other additional steps may be optionally performed after step

236 to additionally or alternatively form other device structures where desired, such as trapped sacrificial structure **104** (e.g., for relative humidity sensor) and/or membrane transducer structure **106** of FIG. **1**.

For example, FIG. **6** illustrates one exemplary embodiment of a membrane transducer structure **106** that may be formed for a capacitive micromachined ultrasonic transducer "CMUT", in part, by incorporating optional step **238** together with optional step **208** of process flow **200A**. As shown in FIG. **6**, transducer contacts **616** and optional lower transducer capacitor plate **612** have been patterned from MEMS layer **315** and its underlying sacrificial release layer during optional step **208**. During steps **212-214**, the first and second sacrificial layers have been patterned such that upper microshell layer **350** forms a transducer membrane **610** that overlies an open area **321** equivalent to the thickness of the first sacrificial layer above lower transducer plate **612**. In this regard, the second sacrificial layer may be removed in step **218** so that the upper microshell layer **350** is deposited in step **230** directly over the first sacrificial layer, which is subsequently removed to form open area **321** during two-step release step **234**. In one exemplary embodiment, a release hole patterning mask may be used to define compliant support structures at release holes **380** on the sides of the membrane, and/or to use the sealing material in release hole areas **380** as anchors to lower level layer **315**.

During optional step **238**, the sealing layer **390** may be masked and patterned to form a transducer opening **695** that exposes an upper surface of the transducer membrane **610** to the ambient environment above the membrane transducer structure **106**. As shown, the exposed transducer membrane **610** is now suspended between a pair of electrically-coupled transducer contacts **616** patterned from MEMS layer **315** in step **208** to provide electrical interconnection to metallization **307** of a circuitry **670** in the IC region through conductive vias **680**. Similar conductive vias **681** may also be provided to electrically couple the lower transducer plate **612** to complementary metallization **307** of a circuitry **671** in the IC region such that relative capacitance between transducer membrane **610** and lower transducer plate **612** may be measured as transducer membrane **610** flexes closer and further away from lower transducer plate **612** due to external stimulus, e.g., such as varying pressure. In another embodiment, a relatively thinner conductive lower transducer plate **612** (e.g., SiGe) may be formed within a relatively thicker area of dielectric material layer **317** that may be left beneath transducer membrane **610**, e.g., relatively thin conductive lower transducer plate **612** may be formed on a top surface of dielectric material layer **317** so that it is embedded within, and exposed at, a top surface of a relatively thicker dielectric material layer portion **317** and coupled to circuitry **671** with conductive vias.

In an optional embodiment, selected area/s of second sacrificial layer may be left during steps **212-214** on top of the first sacrificial area in the area of transducer membrane **610** (e.g., only at one or more outer edges of transducer membrane **610**). These selected area/s of second sacrificial layer material may be left such that the deposited upper microshell layer **350** (together with optional getter layer **334** where present) forms one or more peripheral out-of-plane decoupling structure/s **621** (e.g., such as upwardly extending hinge structure's shown in dashed outline in FIG. **6**) over the remaining area/s of the second sacrificial layer as an alternative to formation of in-plane portions of transducer membrane **610** in these peripheral area/s. As shown, the out-of-plane decoupling structure/s **621** may be formed around an in-plane central portion **623** of the transducer membrane **210**

that is formed by deposited microshell layer **350** over first sacrificial material in those areas where no second sacrificial material is left remaining during steps **212-214**. First and second sacrificial materials beneath the transducer membrane **610** may then be subsequently removed during two-step release step **234** to form open areas **620** under out-of-plane decoupling structures **621** (e.g., similar to main cavity sections **330** of FIG. **3** that include combined cavity portions **320** and **324**) that are contiguous with open area **321** under central portion **623** of the transducer membrane **610** as shown. Where optional out-of-plane structures **621** are so formed, sealing layer **390** may be optionally masked and patterned to form a transducer opening **695** of sufficient size and dimension to allow optional decoupling structures **621** to extend upward through the transducer opening **695**, although in other embodiments sealing layer **390** may be left over at least a portion of decoupling structures **621**.

In one embodiment, one or more out-of-plane decoupling structure's **621** may be optionally formed to help relieve in plane stress for more predictable parametric behavior and increased design flexibility, and further to decouple the membrane **610** from package induced stress so as to increase robustness against temperature variation and offset drift. In one example, four separate out-of-plane structure/s **621** may be formed to be equally spaced around central portion **623** of a circular-shaped, square-shaped or rectangular-shaped membrane transducer **610**, e.g., on each of four sides (e.g., in North-South-East-West oriented relationship) around the periphery of the central portion **623**, although other shapes of membrane transducers **610** and other numbers and/or arrangement of out-of-plane structures **621** may be employed. In one embodiment, out-of-plane stiffness may remain relatively unchanged to retain sensing properties, while the hinge/s or other decoupling structure/s **621** formed by the conformal deposition on top of the thick second sacrificial layer adds a degree of freedom in the plane to relieve in plane stresses.

Examples of membrane transducer types that may be fabricated in this manner include, but are not limited to, pressure sensors, microphones, capacitive micromachined ultrasonic transducers (CMUTs), light modulators, etc. It will be understood that any suitable capacitance measurement circuitry configuration and methodology known in the art may be implemented within the IC region for measuring the changing capacitance between transducer membrane **610** and lower transducer plate **612**, e.g., such as described in U.S. Pat. No. 8,007,167, which is incorporated herein by reference in its entirety.

FIG. **7** illustrates one embodiment of a trapped sacrificial structure **104** (e.g., for a relative humidity sensor) that may be formed, in part, by performing optional step **240** during process flow **200A** of FIG. **2A**. As shown in FIG. **7**, MEMS structural layer **315** has been formed in earlier steps **204-210** to include electrode openings **710** (e.g., formed by patterning of MEMS structural level **315** in step **208**) that extend through MEMS layer **315** as shown. As further shown, first sacrificial material **702** and second sacrificial material **704** are each trapped within filled cavity section **730** beneath upper microshell layer **350**, and are not removed during two-step release process of step **234** e.g., due to selective presence of intervening structural features and/or selective sacrificial and etchant material selection. In one embodiment, first sacrificial layer **702** may be a polyimide and second sacrificial layer **704** may be polyimide. In one embodiment, first sacrificial layer **702** and/or second sacrificial layer **704** may be a humidity-sensitive polyimide or may be any other humidity sensitive sacrificial material that

absorbs water moisture from the surrounding atmosphere and that exhibits different dielectric properties corresponding to the amount of water that the material has absorbed.

As further shown in FIG. **7** a humidity sensor structure may be formed in one exemplary embodiment by removing sacrificial material from beneath MEMS structure layer **315** and from within MEMS electrode openings **710** (e.g., during second germanium etch step of step **234** to also remove sacrificial material remaining in openings **710** after first etch step of step **234**) to provide access for ambient atmosphere to contact a capacitor dielectric structure formed by the polyimide or other type humidity-sensitive first sacrificial layer/s **702** and **704**. In step **240**, second microshell layer **350** and sealing layer **390** may be masked and patterned by etching to create aligned or offset vent hole/s or other inlet openings **715** to provide an access path for ambient atmosphere fluid (e.g., ambient air containing water molecules) to enter the contiguous open area/s **382** beneath MEMS structure layer **315** so that the ambient atmosphere fluid may travel from a given vent hole or inlet opening **715** through a contiguous open area path **382** around conductive vias **780** and **781**, and then up through electrode openings **710** to contact the underside of trapped first polyimide layer **702** through electrode openings **710**. As shown the inlet openings **715** may be created outside (or laterally offset from) the outer periphery of the capacitor dielectric structure formed by the first sacrificial layer **702** and second sacrificial layer **704**. It will be understood that the illustrated embodiment of FIG. **7** having inlet opening defined through dielectric layer **317** (e.g., dielectric material **317** having selective sacrificial and etchant material properties relative to other layers as needed for use in the area of release hole **380** and inlet **715**) is exemplary only, and that in other embodiments an inlet opening **715** may be defined in a release hole area **380** through sealing material layer **390** and an underlying structural layer **315**, rather than dielectric layer **317** which is not present in the area of release hole **380** in such an alternative embodiment.

In the embodiment of FIG. **7**, relative humidity sensor structure **104** may be configured to sense relative humidity by using MEMS structural layer **315** as an electrode for parallel plate capacitance measurement of the alteration of the dielectric properties of the first sacrificial layer polyimide layer **702** due to absorbed water from ambient gas that has penetrated microshell layer **350** through inlet openings **715** and migrated under MEMS structural layer **315** to contact first sacrificial layer **702** through electrode openings **710** as previously described. In one exemplary embodiment, inlet openings **715** and inlet access through a corresponding package hole may be placed away from the effective sensor to allow the decoupling of the sensor size from the package hole size. Since the package hole size determines how small the die and the package can be, a small hole size can help reduce the effective die size without affecting the effective area of the RH sensor. Isolating the sensor from the inlet is also beneficial for robustness and long term stability of the device, e.g., no exposure to mechanical parts during packaging, and no exposure to dust or contaminants during life time of the part.

Advantageously, as illustrated in FIG. **7** the process of FIG. **2A** may be adapted (e.g., using optional step **240**) to leverage the presence of the sacrificial polyimide in layer **702** as well as the MEMS structural layer **315** as first capacitor plate and upper microshell layer **350** as a second capacitor plate to form a parallel plate capacitive sensor that sandwiches humidity-sensitive polyimide material **702** that has been trapped within filled cavity section **730** during the

process sequence. As shown, the second capacitor plate formed from upper microshell layer **350** above the capacitor dielectric structure may be electrically-coupled through conductive vias **780** to metallization **307** of a circuitry **770** in the IC region. Similar conductive vias **781** may also be provided to electrically couple the first capacitor plate formed from MEMS structural layer **315** to complementary metallization **307** of a circuitry **771** such that the changing relative capacitance of the capacitor dielectric structure between the upper and lower capacitor plates may be measured with changing relative humidity of ambient air that enters through inlet opening/s **715**.

It will be understood that any suitable capacitance measurement circuitry configuration and methodology known in the art may be implemented within the IC region for measuring the changing relative capacitance of the capacitor dielectric structure between the upper and lower capacitor plates. Just one example of such known techniques and circuitry may be found in U.S. Pat. No. 8,007,167, which is incorporated herein by reference in its entirety. Moreover, it will also be understood that by selection of appropriate capacitor dielectric materials a similar capacitive sensor structural arrangement may be employed to measure any other changing parameter of an ambient atmosphere fluid that enters inlet hole/s **715** and that affects capacitance of a capacitor dielectric structure formed between the upper and lower capacitor plates.

In one embodiment, a stacked parallel plate capacitor—based sensor may be fabricated that offers higher density of capacitance and higher sensitivity to dielectric constant changes than fringing field based sensors. In one exemplary embodiment, a second matched capacitor structure **104** may also be encapsulated in the same process to provide a reference that is not exposed to humidity variation so as to allow a pseudo differential measurement. This may be accomplished, for example, by not forming electrode openings **710** in MEMS structural layer **315** beneath a capacitor dielectric structure of the second matched capacitor structure, i.e., so that the capacitor dielectric structure is fully encapsulated and sealed between the MEMS structural layer **315** and the upper microshell layer **350**. The second matched capacitor structure may otherwise be of the same dimensions and configuration as a first capacitor structure having underlying electrode openings **710** in fluid communication with the ambient atmosphere such as illustrated in FIG. 7.

It will be understood that FIG. 2A is exemplary only, and that additional, fewer, and/or alternative steps may be employed as needed or desired to fit a given fabrication application. For example, FIG. 2B illustrates one exemplary embodiment of an alternative process flow **200B** that omits steps **224**, **226** and **228** so as to form a single structural layer microshell structure that does not include microshell support lattice members **360**, and is therefore more flexible. In one exemplary embodiment, a relatively thicker and more flexible microshell structural layer **350** may be deposited in step **230** of process flow **200B** than is deposited in corresponding step **230** of process flow **200A** in order to compensate for the absence of microshell support lattice members **360**, e.g., to achieve a stronger microshell layer over a vacuum cavity without the presence of microshell support lattice members **360**.

FIG. 2C illustrates one exemplary embodiment of process flow **200C** for forming a dual structural layer microshell such as illustrated by the vacuum encapsulated device structure **802** of FIG. 8. As shown, process flow **200C** of FIG. 2C includes steps **202-214**, which may be performed in a manner similar to the same steps of process flow **200A** of

FIG. 2A. However, additional steps **290-292** are performed to deposit and pattern a lower microshell layer **850** as shown in FIG. 8 after deposition and patterning of the first sacrificial layer previously described in relation to steps **212-214** of the process flow **200A** of FIG. 2A. In particular, a lower microshell layer is deposited in step **290** over the first sacrificial layer to create a lower microshell layer structure **850** as illustrated in FIG. 8.

The lower (or inner) microshell layer may in one embodiment be a silicon germanium (SiGe) material layer that is deposited by a LPCVD or PECVD process to a thickness of from about 0.5 μm to about 2 μm . However, it will be understood that any other suitable material suitable for forming a lower microshell layer **850** having the characteristics to fit a given application (e.g., good selectivity to release and/or sacrificial etchants, electrical conductivity, etc.) may alternatively be formed over the first sacrificial layer. Examples of other suitable types of lower microshell materials include, but are not limited to, nitride, titanium aluminide (TiAl), tungsten, oxide, nitride, TiAl, germanium, multi-layer (metal stack), etc. Moreover, thickness of lower microshell layer **850** may vary according to the needs of a given application, e.g., formed to be greater than 2 μm or less than 0.5 μm in other possible embodiments.

Next, in step **292**, the lower microshell layer **850** may be masked and patterned to form offset (i.e., non-overlapping and staggered) release holes **980** in lower microshell structure layer **850** as illustrated in FIGS. 9A-9B. As shown, release holes **980** may be patterned to be offset from release holes **380** that are subsequently formed in upper microshell layer **350** in step **232**. In one embodiment, release holes **980** may be offset from release holes **380** with a minimum spacing of about twice the thickness of lower microshell structure layer **850** up to a maximum spacing that is limited by the etch rate of layer **850**. In one exemplary embodiment, release holes **980** may be offset from release holes **380** by about 2 μm to about 10 μm , although release holes **980** may be offset from release holes **380** by a distance greater than about 2 μm or a distance of lesser than about 10 μm in other embodiments. In this “fast release” embodiment, upper release holes **380** and lower release holes **980** together form an etchant travel path (e.g., during step **234**) through the respective upper microshell layer **350** and lower microshell **850** during release of a MEMS structural device formed in MEMS structure layer **315** beneath lower microshell **850**. Downward entry of etchant into upper release holes **380** is illustrated by the arrows in FIG. 9B.

In one exemplary embodiment, the lower release holes **980** may be defined to be laterally closer to a structural device formed in MEMS structure layer **315** beneath microshell layer **850** so as to minimize the lateral etchant travel distance between the lower release holes **980** and the structural device, while at the same time the upper release holes may be defined to be laterally further from the structural device so as to provide the ability to seal the overall structure with sealing material layer **390** (e.g., during sealing layer sputter deposition in step **236**) without risk of depositing the sealing material **390** through the lower release holes **980** in critical device areas on or near the released structural device. In this regard, depending on particular sacrificial etch rates and selectivity, a long undercut beneath MEMS structure layer **315** from the periphery of a structural device may not be possible, and therefore the offset lower release holes **980** of this embodiment may be advantageously placed laterally closer to the device to reduce the undercut distance. In one embodiment, filled cavity sections **830** may be ultimately formed as shown in FIG. 8 between upper microshell layer

350 and lower microshell layer 850. In such an embodiment, no release holes contiguous to the cavity sections 830 are patterned in upper and/or lower microshell layers 350/850, such that cavity sections 830 remain filled with second sacrificial material that is not removed in step 234.

In one exemplary embodiment, first sacrificial material 702 may be removed as shown (e.g., in step 234) to form open areas 320 and 323 between lower microshell layer 850 and MEMS structure layer 315. In an alternate embodiment that is similar to the process described in relation to FIG. 7, first sacrificial material 702 may not be removed from beneath lower microshell layer 850, e.g., so as to leave areas 320 and/or 323 filled with trapped first sacrificial material between lower microshell layer 850 and MEMS structure layer 315. As described in relation to FIG. 7, intervening structural features may be formed or otherwise defined to prevent removal of first sacrificial material 702 during etching of step 234 by closing off any existing etchant path from release holes 380 to at least a portion of a first sacrificial material layer 702, e.g., by closing off or not forming release holes 980 of FIG. 9 that would otherwise communicate etchant to this trapped portion of first sacrificial material 702. In such an alternate embodiment, a trapped sacrificial structure of humidity-sensitive first sacrificial layer 702 may be formed beneath lower microshell layer 850 and above MEMS structure layer 315 and may be implemented as a capacitor dielectric structure for a relative humidity sensor in a manner similar to that described in relation to FIG. 7, with the exception that lower microshell layer 850 is configured in this case as a second capacitor plate that together forms a parallel plate capacitive sensor with the first capacitor plate of MEMS structure layer 315 by sandwiching humidity-sensitive polyimide material 702 therebetween. Otherwise similar processing steps as described in relation to FIG. 7 may be employed, i.e., to form electrode openings 710 in MEMS structural layer 315 and open area/s 382 beneath MEMS structure layer 315, together with vent hole/s or other inlet openings 715 to provide an access path for ambient atmosphere to enter the contiguous open area/s 382 beneath MEMS structure layer 315 so that it may travel to contact the underside of trapped first polyimide layer 702 through the electrode openings 710.

FIG. 2D illustrates another exemplary embodiment of a process flow 200D for forming a dual structural layer microshell that is similar to the process flow 200C of FIG. 2C, with the exception that step 292 for patterning the offset inner release holes is omitted. In this “edge release” embodiment, release holes are located on the edge/s of the formed structural device rather than at inner locations.

FIG. 10 illustrates one embodiment in which two or more trapped sacrificial material structures 1004 may be formed together as a spacer structure 1050 around a relatively fragile or sensitive area 1010 of a semiconductor device die 1090, such as a membrane transducer structure 106 of FIG. 6. As shown in FIG. 10, first sacrificial material 702 and second sacrificial material 704 are each trapped within filled cavity section 730 beneath upper microshell layer 350, and are not removed during two-step release process of step 234 in a manner similar to that described in relation to FIG. 7. Spacer structure 1050 may be useful, for example, in combination with sensors device structures such as environmental sensors (e.g., humidity, pressure, temperature), acoustic sensors, optical sensors and chemical sensors that require an opening in a fabricated package to act as an inlet for light, liquid, vapor, and/or gas toward the underlying sensor device of die 1090. Such a sensor opening is usually

achieved using a package molding process that employs high pressure contact with the die using a tool 1020 that pulls a vacuum on the die and can crack the die and/or damage the sensor of the fragile/sensitive area 1010. As shown in FIG. 10, multiple trapped sacrificial material structures 1004 may be spaced apart by an amount suitable for acting as a stand-off to space or separate the molding tool 1020 from the fragile/sensitive area 1010 when the tool 1020 mechanically contacts the die during the molding step, thus improving manufacturability due to improved alignment tolerances.

As used herein, a layer or other structure/feature that is formed over a substrate includes a given layer or other structure/feature that is disposed over and in direct contact with an underlying substrate material (e.g., a semiconductor wafer material) as well as a given layer or other structure/feature that is not disposed in direct contact with an underlying substrate material but that is instead disposed over one or more intervening layers or other structures/features (e.g., such as intervening cavities, metal layers, and/or insulative layers) that are disposed between the given layer or other structure/feature and the substrate such that the given layer or other structure/feature does not directly contact the underlying substrate. Thus the term “over” connotes both direct overlying contact with an underlying layer or other structure/feature, as well as a non-contacting overlying relationship with an underlying layer or other structure/feature, e.g., with one or more intervening layers or other structures/features disposed therebetween. Likewise, the term “under” connotes both direct underlying contact with an overlying layer or other structure/feature, as well as a non-contacting underlying relationship with an overlying layer or other structure/feature, e.g., with one or more intervening layers or other structures/features disposed therebetween.

While the invention may be adaptable to various modifications and alternative forms, specific embodiments have been shown by way of example and described herein. However, it should be understood that the invention is not intended to be limited to the particular forms disclosed. Rather, the invention is to cover all modifications, equivalents, and alternatives falling within the spirit and scope of the invention as defined by the appended claims. Moreover, the different aspects of the disclosed methods and structures may be utilized in various combinations and/or independently. Thus the invention is not limited to only those combinations shown herein, but rather may include other combinations.

What is claimed is:

1. A method of forming a microshell structure, comprising:

forming a first sacrificial layer over a MEMS region and an underlying substrate, and removing a part of the first sacrificial layer to leave one or more remaining portions of the first sacrificial layer;

forming a second sacrificial layer over the remaining portions of the first sacrificial layer, the second sacrificial layer being thicker than the first sacrificial layer, and removing a part of the second sacrificial layer to leave one or more remaining portions of the second sacrificial layer over at least a part of the remaining portions of the first sacrificial layer;

forming an upper microshell layer over the remaining portions of the first and second sacrificial layers; creating one or more upper release holes in the upper microshell layer;

removing at least a part of the remaining portions of the first and/or second sacrificial layers through the upper

19

release holes to form one or more open cavities or open areas under the upper microshell layer; and forming a sealing layer on the upper microshell layer to seal the upper release holes in the upper microshell layer.

2. The method of claim 1, further comprising removing a part of the second sacrificial layer that is over the first sacrificial layer to leave one or more remaining portions of the first sacrificial layer that are not overlain by the second sacrificial layer.

3. The method of claim 1, further comprising:

forming a lower microshell layer over the remaining portions of the first sacrificial layer;

creating one or more lower release holes in the lower microshell layer;

forming the second sacrificial layer over the lower microshell layer and the remaining portions of the first sacrificial layer, and removing a part of the second sacrificial layer to leave one or more remaining portions of the second sacrificial layer over the lower microshell layer and at least a part of the remaining portions of the first sacrificial layer;

forming the upper microshell layer over the remaining portions of the first sacrificial layer, the lower microshell layer, and the remaining portions of the second sacrificial layer;

removing at least a part of the remaining portions of the first and/or second sacrificial layers through the upper and/or lower release holes to form one or more open cavities or open areas under the upper microshell layer; and

forming a sealing layer on the upper microshell layer to seal the upper release holes in the upper microshell layer.

4. The method of claim 3, further comprising:

removing at least a part of the remaining portions of the first sacrificial layer through the upper and lower release holes to form one or more open cavities or open areas under the upper and lower microshell layers; and not removing at least a part of the remaining portions of the second sacrificial layer so as to form a filled cavity section between the upper microshell layer and the lower microshell layer.

5. The method of claim 3, further comprising forming the lower release holes to be laterally offset from the upper release holes.

6. The method of claim 5, further comprising:

forming the MEMS region to include a MEMS structural layer defining one or MEMS devices over a MEMS release layer prior to forming the first sacrificial layer over the MEMS region; and

removing the MEMS release layer through the upper and lower release holes in one or more areas beneath the MEMS structural layer to release the MEMS devices formed therein following the step of removing at least a part of the remaining portions of the first and/or second sacrificial layers through the upper and/or lower release holes to form one or more open cavities or open areas under the upper microshell layer and prior to forming the sealing layer on the upper microshell layer to seal the upper release holes in the upper microshell layer.

7. The method of claim 1, further comprising forming a residual gas getter layer over the remaining portions of the first and second sacrificial layers prior to removing at least a part of the remaining portions of the first and/or second

20

sacrificial layers through the upper release holes to form one or more open cavities or open areas under the upper microshell layer.

8. The method of claim 1, further comprising forming the second sacrificial layer over and in contact with the remaining portions of the first sacrificial layer, and removing a part of the second sacrificial layer to leave one or more remaining portions of the second sacrificial layer overlying and in contact with at least a part of the remaining portions of the first sacrificial layer.

9. The method of claim 8, further comprising removing a part of the second sacrificial layer to leave one or more portions of the second sacrificial layer overlying and in contact with one or more portions of the first sacrificial layer.

10. The method of claim 9, further comprising removing the one or more portions of the second sacrificial layer together with one or more underlying portions of the first sacrificial layer through the upper release holes to form at least one open main cavity section under the upper microshell layer prior to forming a sealing layer on the upper microshell layer to seal the upper release holes in the upper microshell layer.

11. The method of claim 9, further comprising leaving the one or more portions of the second sacrificial layer together with and in contact with the one or more underlying portions of the first sacrificial layer to form at least one filled main cavity section under the upper microshell layer prior to forming a sealing layer on the upper microshell layer to seal the upper release holes in the upper microshell layer.

12. The method of claim 8, further comprising forming a mold for one or more microshell support lattice members that extend downward into the remaining portions of the second sacrificial layer and terminate above the remaining portions of the first sacrificial layer prior to forming the upper microshell layer over the remaining portions of the first and second sacrificial layers; and forming the upper microshell layer to fill the mold within the remaining portions of the second sacrificial layer to create one or more microshell support lattice members that extend downward from an underside of the upper microshell layer.

13. The method of claim 12, further comprising removing remaining portions of the first and second sacrificial layers through the upper release holes to form at least one open cavity under the upper microshell layer that is surrounded by peripheral edges with the microshell support lattice members extending downward into the open cavity from the underside of the upper microshell layer to terminate above the MEMS region without contacting the MEMS region and with the upper microshell layer contacting the MEMS region at the peripheral edges of the open cavity so as to suspend the upper microshell layer and microshell support lattice members over the open cavity.

14. The method of claim 13, where the mold defines a pattern of multiple microshell support lattice members between the peripheral edges of the open cavity; and where the method further comprises removing remaining portions of the first and second sacrificial layers through the upper release holes to form an array of open cavity sections defined by the microshell support lattice members under the upper microshell layer.

15. The method of claim 1, further comprising:

forming the MEMS region to include a MEMS structural layer defining one or MEMS devices over a MEMS release layer prior to forming the first sacrificial layer over the MEMS region; and

removing the MEMS release layer through the upper release holes in one or more areas beneath the MEMS

structural layer to release the MEMS devices formed therein following the step of removing at least a part of the remaining portions of the first and/or second sacrificial layers through the upper release holes to form one or more open cavities or open areas under the upper microshell layer and prior to forming the sealing layer on the upper microshell layer to seal the upper release holes in the upper microshell layer. 5

16. The method of claim 1, further comprising:

forming the MEMS region to include a metallization layer under an electrically insulative material layer and a MEMS structural layer above the electrically insulative material layer; 10

forming a pad region with a pad opening to the metallization layer through the MEMS structural layer and the electrically insulative material prior to the step of forming the first sacrificial layer over the MEMS region; 15

removing the first sacrificial layer and second sacrificial layer within the pad region prior to forming the upper microshell layer; 20

forming an opening through the upper microshell layer over the pad region to the MEMS metallization layer; and

forming the sealing layer by shadow mask deposition of a conductive sealing layer to contact the metallization layer of the MEMS region through the pad opening and form a conductive electrical pad. 25

* * * * *