



US010190914B2

(12) **United States Patent**  
**Jeong**

(10) **Patent No.:** **US 10,190,914 B2**  
(45) **Date of Patent:** **Jan. 29, 2019**

(54) **MOTION DETECTION FOR A/V RECORDING AND COMMUNICATION DEVICES**

*13/19* (2013.01); *G08B 13/19695* (2013.01);  
*G08B 29/185* (2013.01); *H04N 7/186*  
(2013.01); *H04N 7/188* (2013.01); *G01J*  
*2001/4266* (2013.01); *G08B 13/19656*  
(2013.01)

(71) Applicant: **Ring Inc.**, Santa Monica, CA (US)

(58) **Field of Classification Search**  
CPC ..... G11B 20/10527; G11B 20/00891; G01J  
1/4204; G01J 5/0025; G01J 5/26  
See application file for complete search history.

(72) Inventor: **Changsoo Jeong**, Rancho Palos Verdes, CA (US)

(73) Assignee: **Amazon Technologies, Inc.**, Seattle, WA (US)

(56) **References Cited**

(\*) Notice: Subject to any disclaimer, the term of this patent is extended or adjusted under 35 U.S.C. 154(b) by 0 days.

U.S. PATENT DOCUMENTS

4,764,953 A 8/1988 Chern et al.  
5,428,388 A 6/1995 von Bauer et al.  
5,448,290 A 9/1995 VanZeeland  
(Continued)

(21) Appl. No.: **15/359,407**

(22) Filed: **Nov. 22, 2016**

FOREIGN PATENT DOCUMENTS

(65) **Prior Publication Data**

US 2017/0163944 A1 Jun. 8, 2017

CN 2585521 Y 11/2003  
CN 2792061 Y 6/2006  
(Continued)

**Related U.S. Application Data**

OTHER PUBLICATIONS

(60) Provisional application No. 62/289,072, filed on Jan. 29, 2016, provisional application No. 62/263,334, filed on Dec. 4, 2015.

H264 WebCam Introduction. (53 pages).  
(Continued)

(51) **Int. Cl.**

*H04N 7/18* (2006.01)  
*G01J 5/00* (2006.01)  
*G01J 5/02* (2006.01)  
*G08B 13/196* (2006.01)  
*G01J 1/42* (2006.01)  
*G08B 13/19* (2006.01)  
*G08B 29/18* (2006.01)

*Primary Examiner* — Mishawn N Hunter

(74) *Attorney, Agent, or Firm* — Chong IP Law, LLP

(52) **U.S. Cl.**

CPC ..... *G01J 5/0025* (2013.01); *G01J 1/4204*  
(2013.01); *G01J 5/0205* (2013.01); *G01J*  
*5/025* (2013.01); *G01J 5/026* (2013.01); *G08B*

(57) **ABSTRACT**

Audio/video (A/V) recording and communication devices according to the present embodiments comprise a processor, a motion sensor, and a camera. In various embodiments, the A/V recording and communication devices are configured to reduce latency and/or to reduce false positive indications of motion.

**15 Claims, 30 Drawing Sheets**

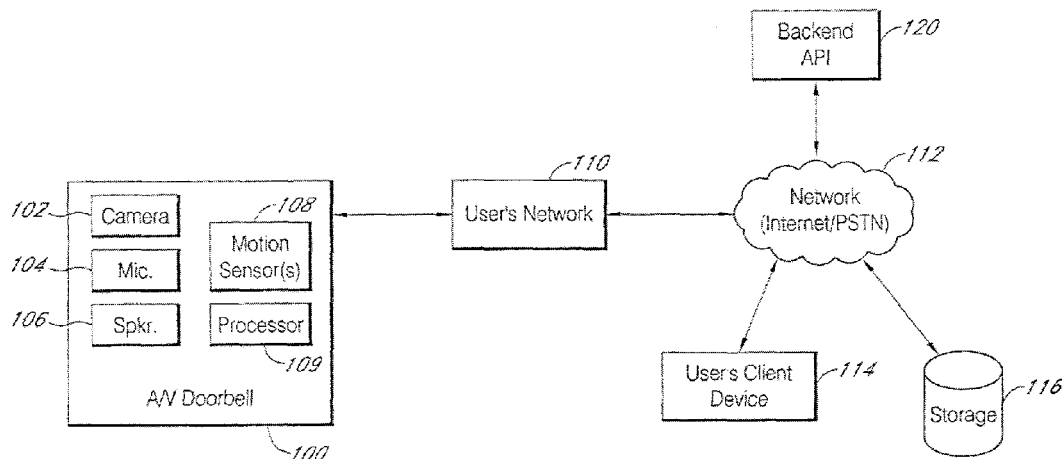

(56)

References Cited

U.S. PATENT DOCUMENTS

5,546,072 A \* 8/1996 Creuseremee ..... G08B 13/1966  
340/514  
5,666,157 A \* 9/1997 Aviv ..... G08B 13/19602  
348/150  
5,760,848 A 6/1998 Cho  
6,028,626 A 2/2000 Aviv  
6,072,402 A 6/2000 Kniffin et al.  
6,192,257 B1 2/2001 Ray  
6,271,752 B1 8/2001 Vaios  
6,429,893 B1 8/2002 Xin  
6,456,322 B1 9/2002 Marinacci  
6,476,858 B1 11/2002 Ramirez Diaz et al.  
6,633,231 B1 10/2003 Okamoto et al.  
6,658,091 B1 12/2003 Naidoo et al.  
6,696,945 B1 2/2004 Venetianer et al.  
6,707,486 B1 3/2004 Millet et al.  
6,753,774 B2 6/2004 Pan et al.  
6,970,183 B1 11/2005 Monroe  
7,062,291 B2 6/2006 Ryley et al.  
7,065,196 B2 6/2006 Lee  
7,085,361 B2 8/2006 Thomas  
7,109,860 B2 9/2006 Wang  
7,161,152 B2 1/2007 DiPoala  
7,193,644 B2 3/2007 Carter  
7,242,423 B2 7/2007 Lin  
7,304,572 B2 12/2007 Sheynman et al.  
7,339,608 B2 3/2008 Ryley et al.  
7,382,249 B2 6/2008 Fancella  
7,417,535 B2 8/2008 Mathews et al.  
7,450,638 B2 11/2008 Iwamura  
7,486,271 B2 2/2009 Hershkovitz et al.  
7,643,056 B2 1/2010 Silsby  
7,683,924 B2 3/2010 Oh et al.  
7,683,929 B2 3/2010 Elazar et al.  
7,738,917 B2 6/2010 Ryley et al.  
8,139,098 B2 3/2012 Carter  
8,144,183 B2 3/2012 Carter  
8,154,581 B2 4/2012 Carter  
8,189,049 B2 5/2012 Lopota et al.  
8,619,136 B2 12/2013 Howarter et al.  
8,780,201 B1 7/2014 Scalisi et al.  
8,804,997 B2 8/2014 Gagvani et al.  
8,823,795 B1 9/2014 Scalisi et al.  
8,842,180 B1 9/2014 Kasmir et al.  
8,872,915 B1 10/2014 Scalisi et al.  
8,922,649 B2 12/2014 Kim  
8,937,659 B1 1/2015 Scalisi et al.  
8,941,736 B1 1/2015 Scalisi et al.  
8,947,530 B1 2/2015 Scalisi  
8,953,040 B1 2/2015 Scalisi et al.  
9,013,575 B2 4/2015 Scalisi  
9,046,414 B2 6/2015 Fadell et al.  
9,049,352 B2 6/2015 Scalisi et al.  
9,053,622 B2 6/2015 Scalisi  
9,055,202 B1 6/2015 Scalisi et al.  
9,058,738 B1 6/2015 Scalisi  
9,060,103 B2 6/2015 Scalisi  
9,060,104 B2 6/2015 Scalisi  
9,065,987 B2 6/2015 Kasmir et al.  
9,094,584 B2 7/2015 Scalisi et al.  
9,109,378 B2 8/2015 Scalisi  
9,113,051 B1 8/2015 Scalisi  
9,113,052 B1 8/2015 Scalisi et al.  
9,118,819 B1 8/2015 Scalisi et al.  
9,142,214 B2 9/2015 Scalisi  
9,160,987 B1 10/2015 Kasmir et al.  
9,165,444 B2 10/2015 Scalisi  
9,172,920 B1 10/2015 Kasmir et al.  
9,172,921 B1 10/2015 Scalisi et al.  
9,172,922 B1 10/2015 Kasmir et al.  
9,179,107 B1 11/2015 Scalisi et al.  
9,179,108 B1 11/2015 Scalisi et al.  
9,179,109 B1 11/2015 Kasmir et al.  
9,196,133 B2 11/2015 Scalisi et al.  
9,197,867 B1 11/2015 Scalisi et al.

9,230,424 B1 1/2016 Scalisi et al.  
9,237,318 B2 1/2016 Kasmir et al.  
9,247,219 B2 1/2016 Kasmir et al.  
9,253,455 B1 2/2016 Harrison et al.  
9,342,936 B2 5/2016 Scalisi  
9,386,281 B2 7/2016 Trundle et al.  
9,398,266 B2 7/2016 Keidar et al.  
9,508,239 B1 11/2016 Harrison et al.  
9,736,284 B2 8/2017 Scalisi et al.  
9,743,049 B2 8/2017 Scalisi et al.  
9,769,435 B2 9/2017 Scalisi et al.  
9,786,133 B2 10/2017 Harrison et al.  
9,799,183 B2 10/2017 Harrison et al.  
2002/0008758 A1 1/2002 Broemmelsiek et al.  
2002/0094111 A1 7/2002 Puchek et al.  
2002/0147982 A1 10/2002 Naidoo et al.  
2002/0163577 A1 11/2002 Myers  
2003/0043047 A1 3/2003 Braun  
2004/0085205 A1 5/2004 Yeh  
2004/0085450 A1 5/2004 Stuart  
2004/0086093 A1 5/2004 Schranz  
2004/0095254 A1 5/2004 Maruszczyk  
2004/0135686 A1 7/2004 Parker  
2005/0043907 A1 2/2005 Eckel et al.  
2005/0111660 A1 5/2005 Hosoda  
2006/0010199 A1 1/2006 Brailean et al.  
2006/0022816 A1 2/2006 Yukawa  
2006/0139449 A1 6/2006 Cheng et al.  
2006/0156361 A1 7/2006 Wang et al.  
2007/0008081 A1 1/2007 Tylicki et al.  
2007/0029486 A1 2/2007 Zhevelev et al.  
2007/0173083 A1\* 7/2007 Kopplin ..... H04L 12/403  
439/76.1  
2007/0252693 A1 11/2007 Janson  
2009/0309029 A1\* 12/2009 Zhevelev ..... G01J 5/0022  
250/353  
2009/0327949 A1 12/2009 Subbian et al.  
2010/0195810 A1 8/2010 Mota et al.  
2010/0225455 A1 9/2010 Claiborne et al.  
2011/0156898 A1 6/2011 Taillerfer et al.  
2011/0157358 A1 6/2011 Bell  
2012/0218086 A1\* 8/2012 Miller ..... G08B 13/19  
340/10.33  
2013/0057695 A1 3/2013 Huisking  
2013/0215276 A1 8/2013 Cho  
2014/0088761 A1 3/2014 Shamlian et al.  
2014/0267716 A1 9/2014 Child et al.  
2014/0362225 A1 12/2014 Ramalingamoorthy et al.  
2015/0022344 A1 1/2015 Matsuoka et al.  
2015/0022620 A1\* 1/2015 Siminoff ..... H04M 11/025  
348/14.02  
2015/0029334 A1\* 1/2015 Scalisi ..... H04N 7/188  
348/143  
2015/0161882 A1\* 6/2015 Lett ..... G08B 25/001  
340/506  
2015/0163463 A1 6/2015 Hwang et al.  
2016/0300479 A1\* 10/2016 Modi ..... G08B 29/183

FOREIGN PATENT DOCUMENTS

EP 0944883 B1 2/1997  
EP 1480462 A1 11/2004  
EP 2587462 A1 5/2013  
GB 2286283 A 8/1995  
GB 2354394 A 3/2001  
GB 2357387 A 6/2001  
GB 2400958 A 10/2004  
JP 2001-103463 4/2001  
JP 2002-033839 1/2002  
JP 2002-125059 4/2002  
JP 2002-342863 11/2002  
JP 2002-344640 11/2002  
JP 2002-354137 12/2002  
JP 2002-368890 12/2002  
JP 2003-283696 10/2003  
JP 2004-128835 4/2004  
JP 2005-341040 12/2005  
JP 2006-147650 6/2006

(56)

**References Cited**

FOREIGN PATENT DOCUMENTS

JP	2006-262342	9/2006
JP	2009-008925	1/2009
WO	9839894	9/1998
WO	0113638 A1	2/2001
WO	0129795 A1	4/2001
WO	0193220 A1	6/2001
WO	02085019 A1	10/2002
WO	03028375 A1	4/2003
WO	06038760 A1	4/2006
WO	2006046234 A2	5/2006
WO	2006067782 A1	6/2006
WO	2003096696 A2	9/2006
WO	2007125143 A1	11/2007

OTHER PUBLICATIONS

Cisco. Cisco Video Surveillance Manager User Guide, Release 6.3. (354 pages).  
 D-Link. Wireless N Day & Night Pan/Tilt Cloud Camera DCS-5020L. User Manual. Version 1.0 (Mar. 25, 2013) (58 pages).  
 AXIS Communications. AXIS Camera Station User's Manual, Rev. 6.0 (Jun. 2009) (63 pages).  
 AXIS Communications. AXIS Camera Station User's Manual, Rev. 7.0 (Apr. 2010) (70 pages).

Genetec, Inc. Omnicast 4.4 Administrator Guide. Doc. No. EN.100.005-V4.4.(1) (Mar. 2009) (606 pages).  
 MOBOTIX. MxControlCenter Professional Video Management. MXCC User Manual. The HiRes Video Company. V 2.5.3, (Mar. 2013) (392 pages).  
 MOBOTIX. MxEasy: Point & Shoot. MxEasy User Manual. The HiRes Video Company. (Mar. 2010) (132 pages).  
 MOBOTIX. MxEasy The Easy-To-User Video Software. MxEasy User Manual. The HiRes Video Company. (Apr. 2012) (126 pages).  
 MOBOTIX. Software Camera Manual Part 3 (Oct. 10, 2006) (18 pages).  
 NUUO. Intelligent Video Surveillance (IVS) (Oct. 2012) (2 pages).  
 Cisco Small Business Video Monitoring System for SWVMS16 Basic, VM 200-32 Basic Plus, VM 300-xx Advanced Administration Guide. (Copyright 2010 Cisco Systems, Inc.) (220 pages).  
 CITILOG. MediaTD Brochure. Video-Based Non-Intrusive Real Time Traffic Data Collection Solution. (2012) (2 pages).  
 Seifried, K. linux-magazine.com, Issue 125. Security Lessons: Secure Video. Secure Video Surveillance. Camera Shy. (Apr. 2011) (2 pages).  
 Vision Controls Corp. Hybrid Video Recorder User Training Guide. (HVR) Version 2.6.5. (2007) (20 pages).  
 TUXRADARLINUX. Build your own CCTV system with Zoneminder. (Jul. 13, 2012) (7 pages).  
 Esprit 728 Series Control Panels Reference and Installation Manual. (Apr. 2004) (52 pages).

\* cited by examiner

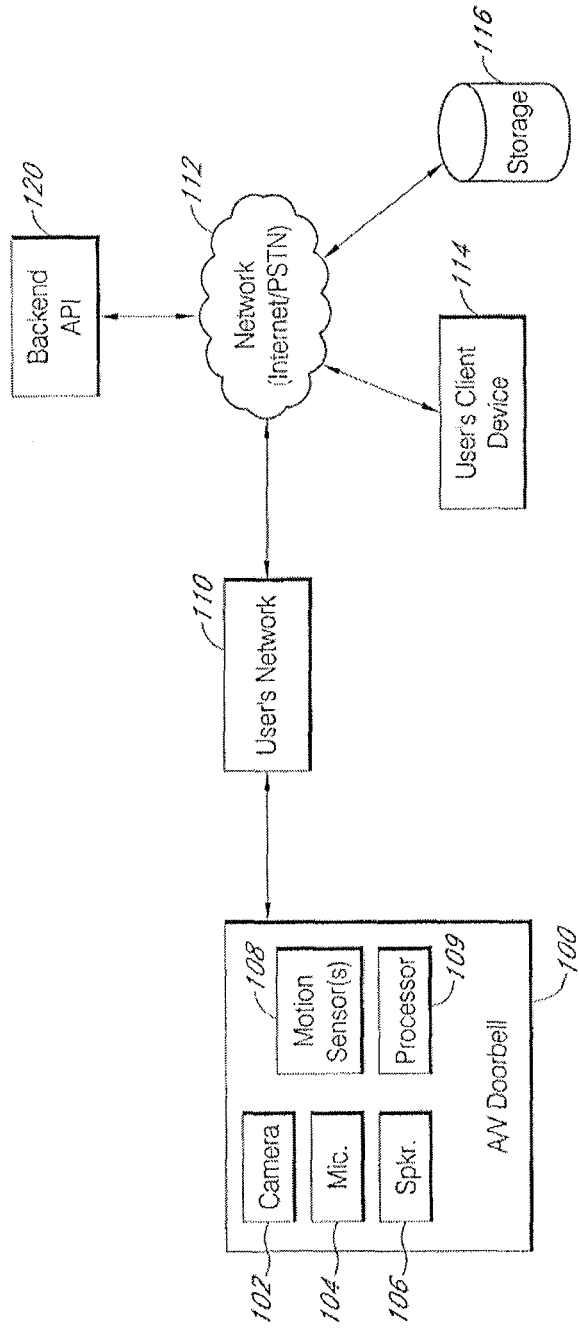

FIG. 1

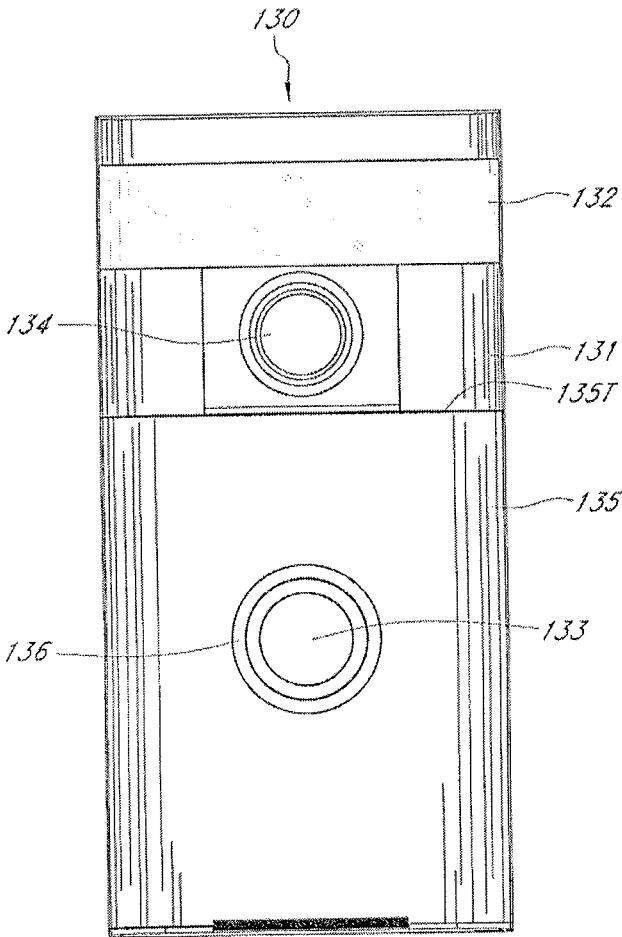

FIG. 2

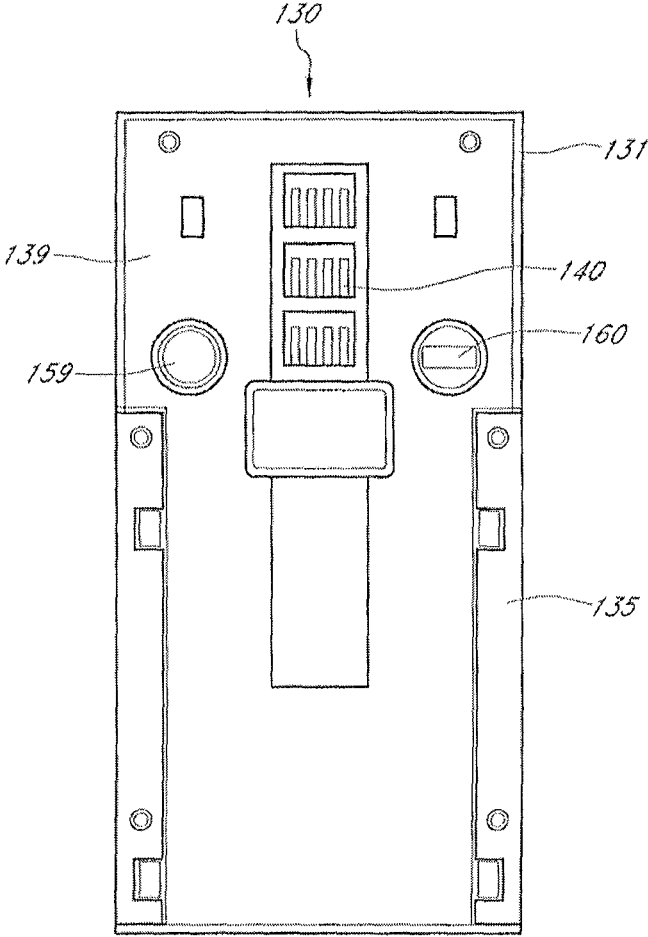

FIG. 3

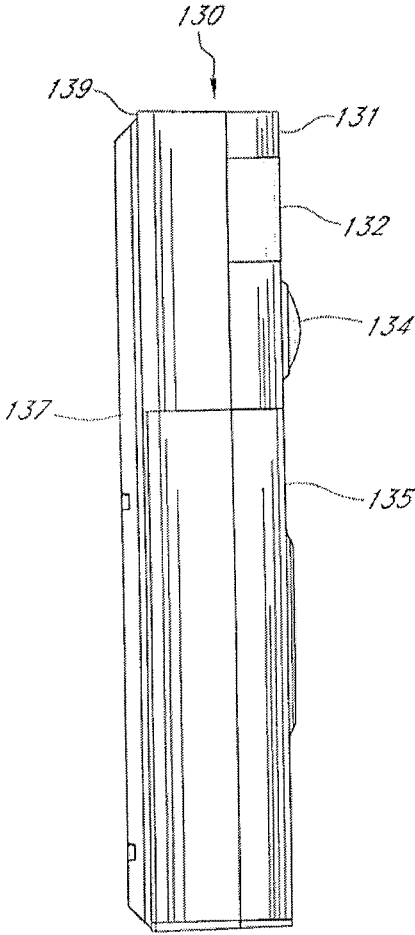

FIG. 4

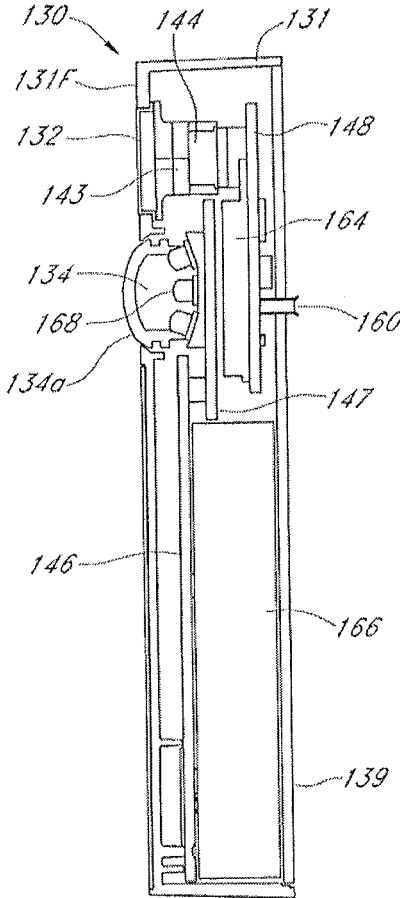

FIG. 5



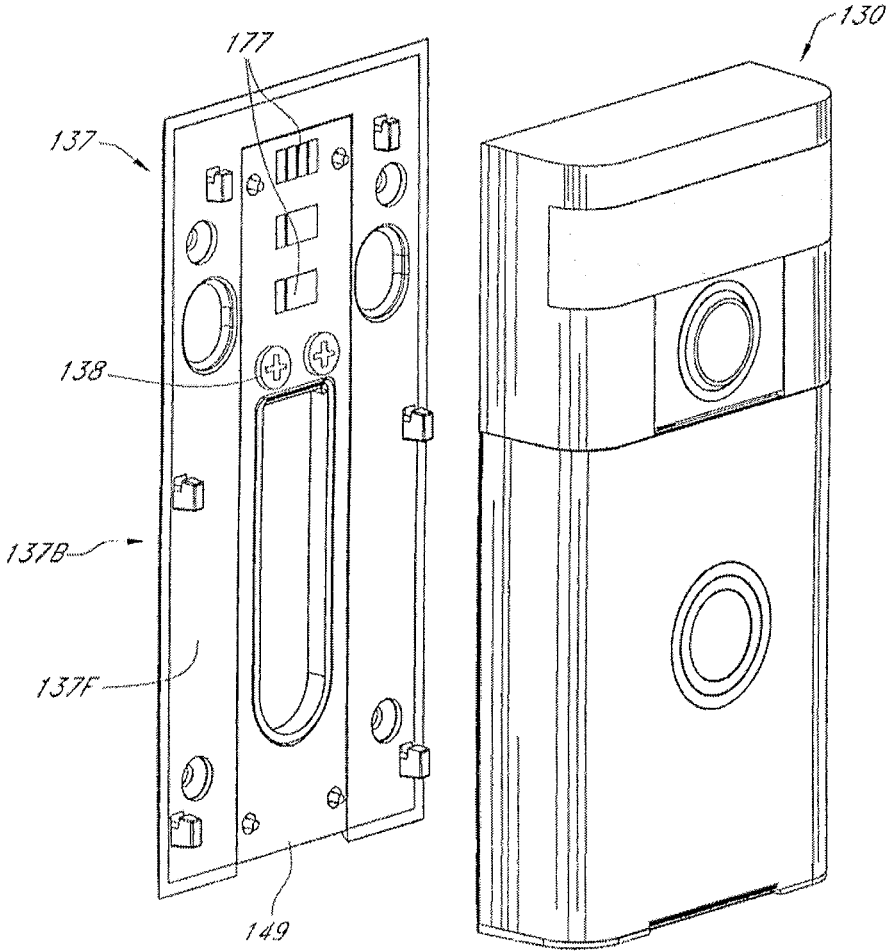

FIG. 6

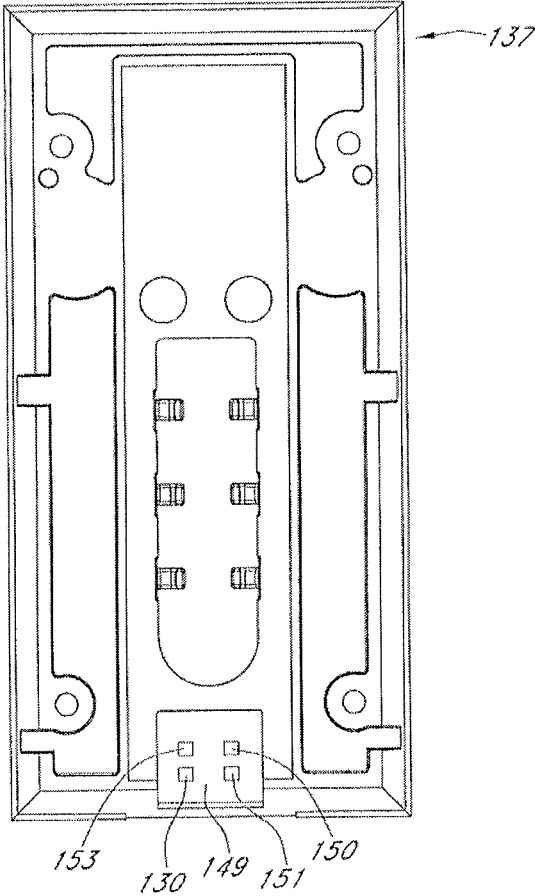

FIG. 7

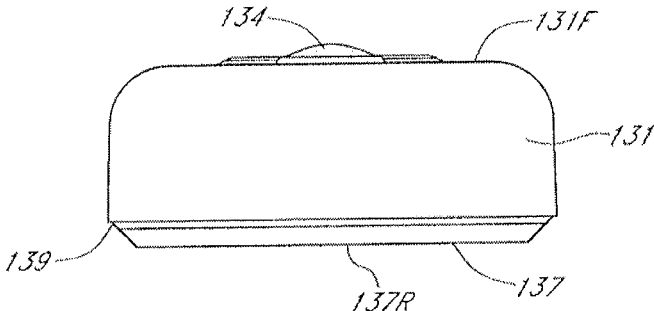

FIG. 8A

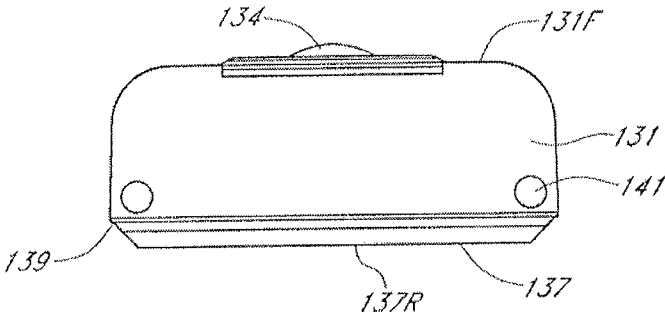

FIG. 8B

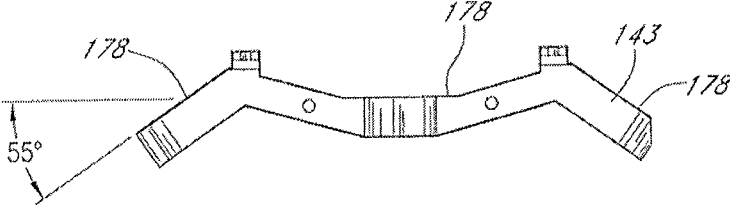

FIG. 9A

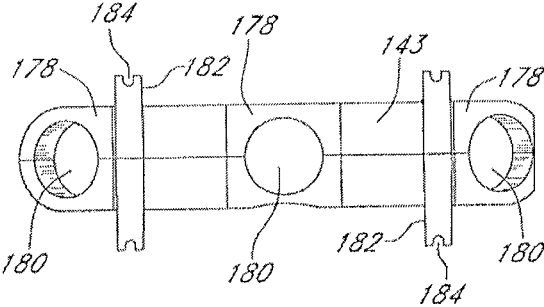

FIG. 9B

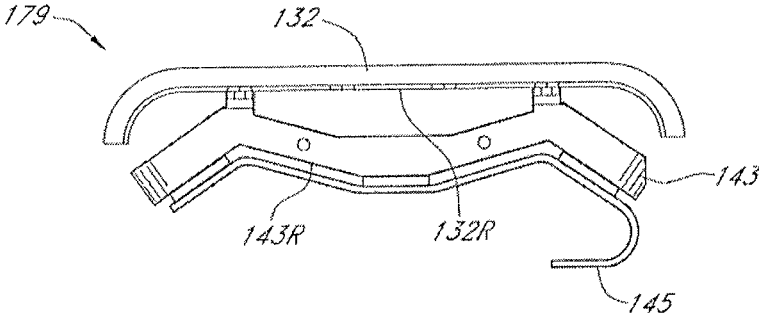

FIG. 10A

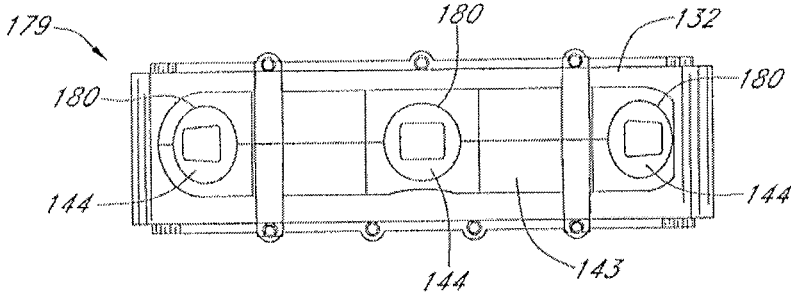

FIG. 10B

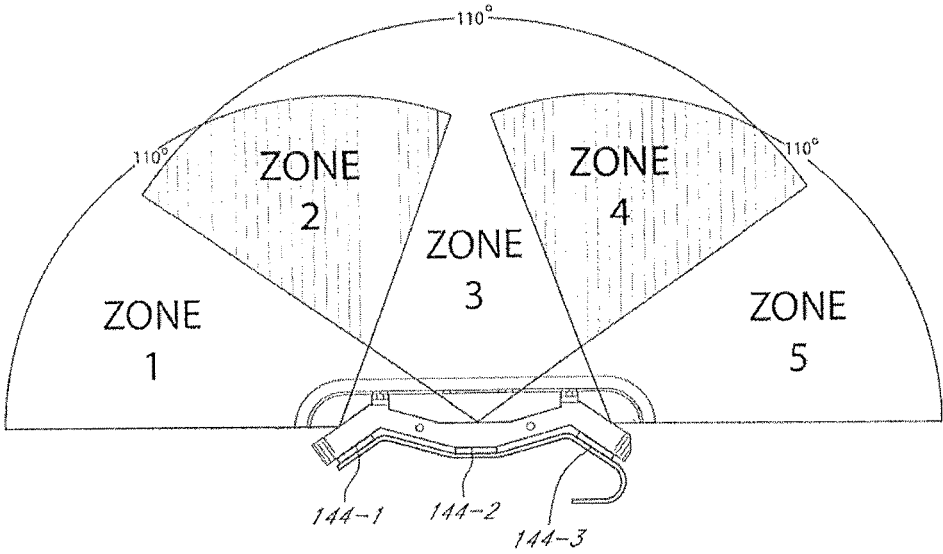

FIG. 11

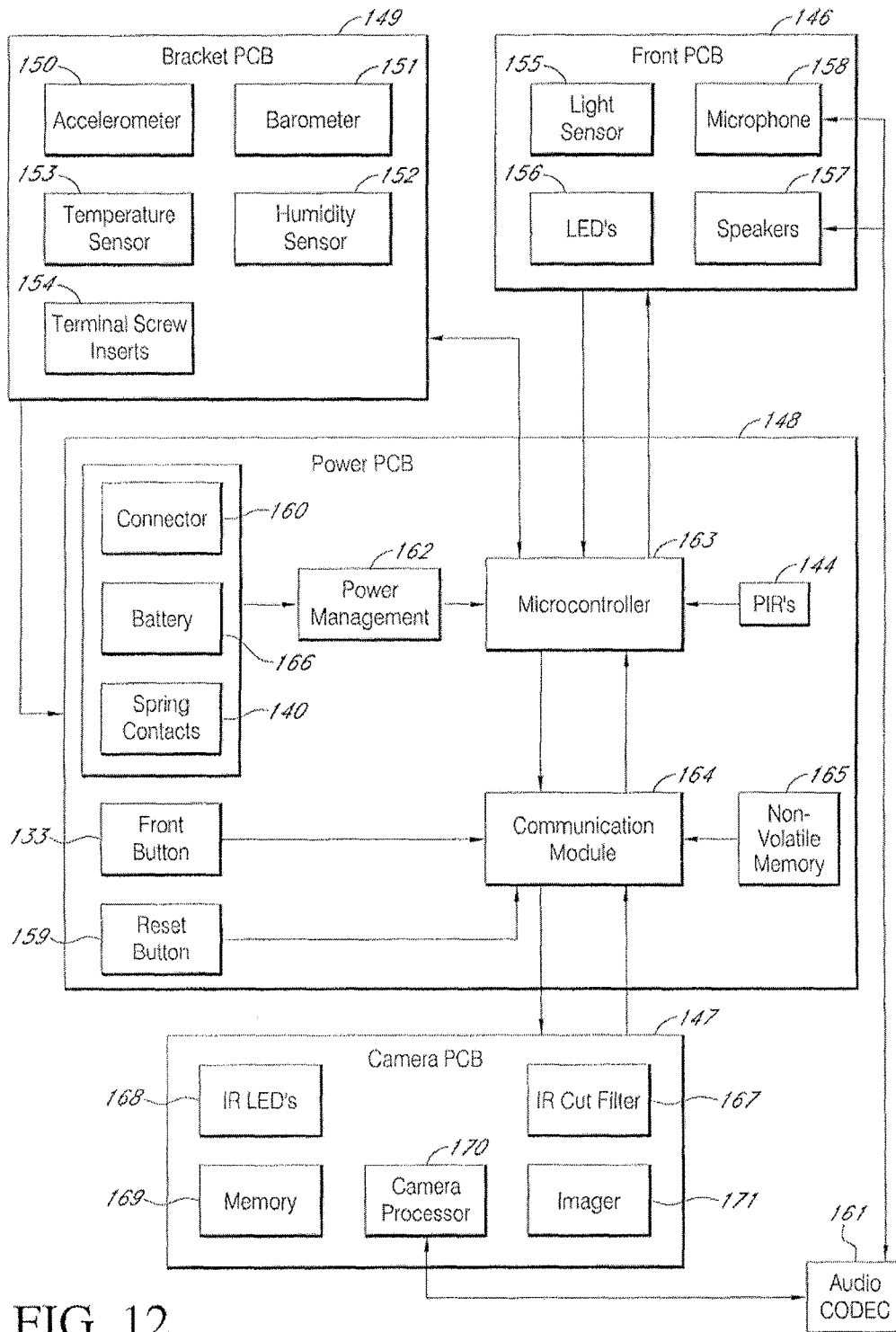

FIG. 12

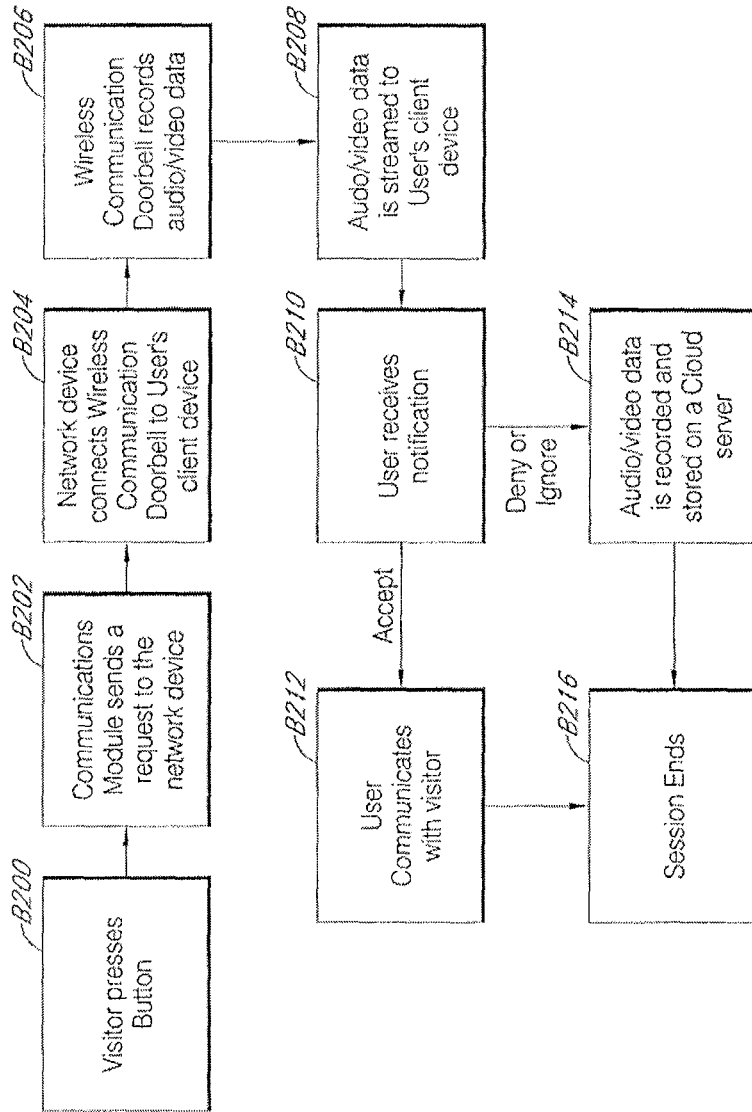

FIG. 13





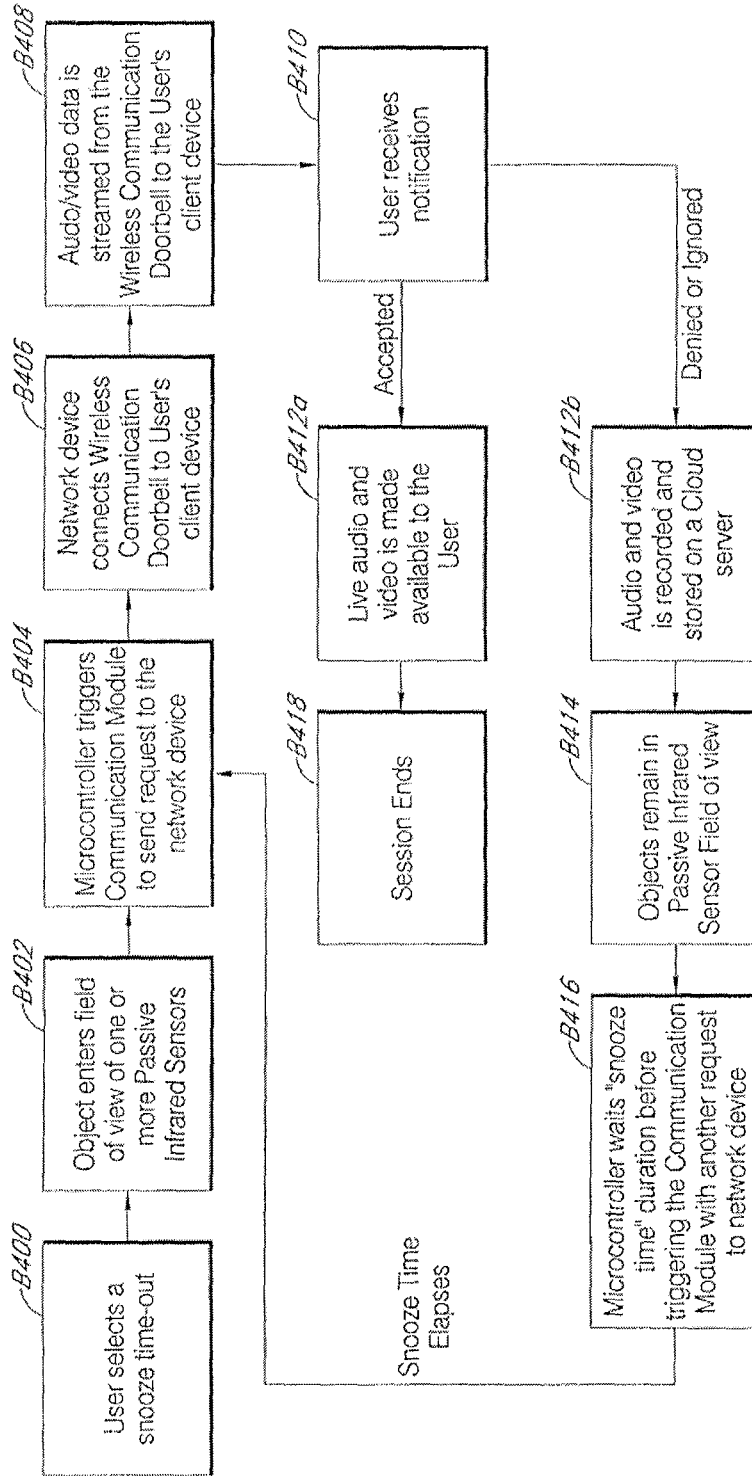

FIG. 15

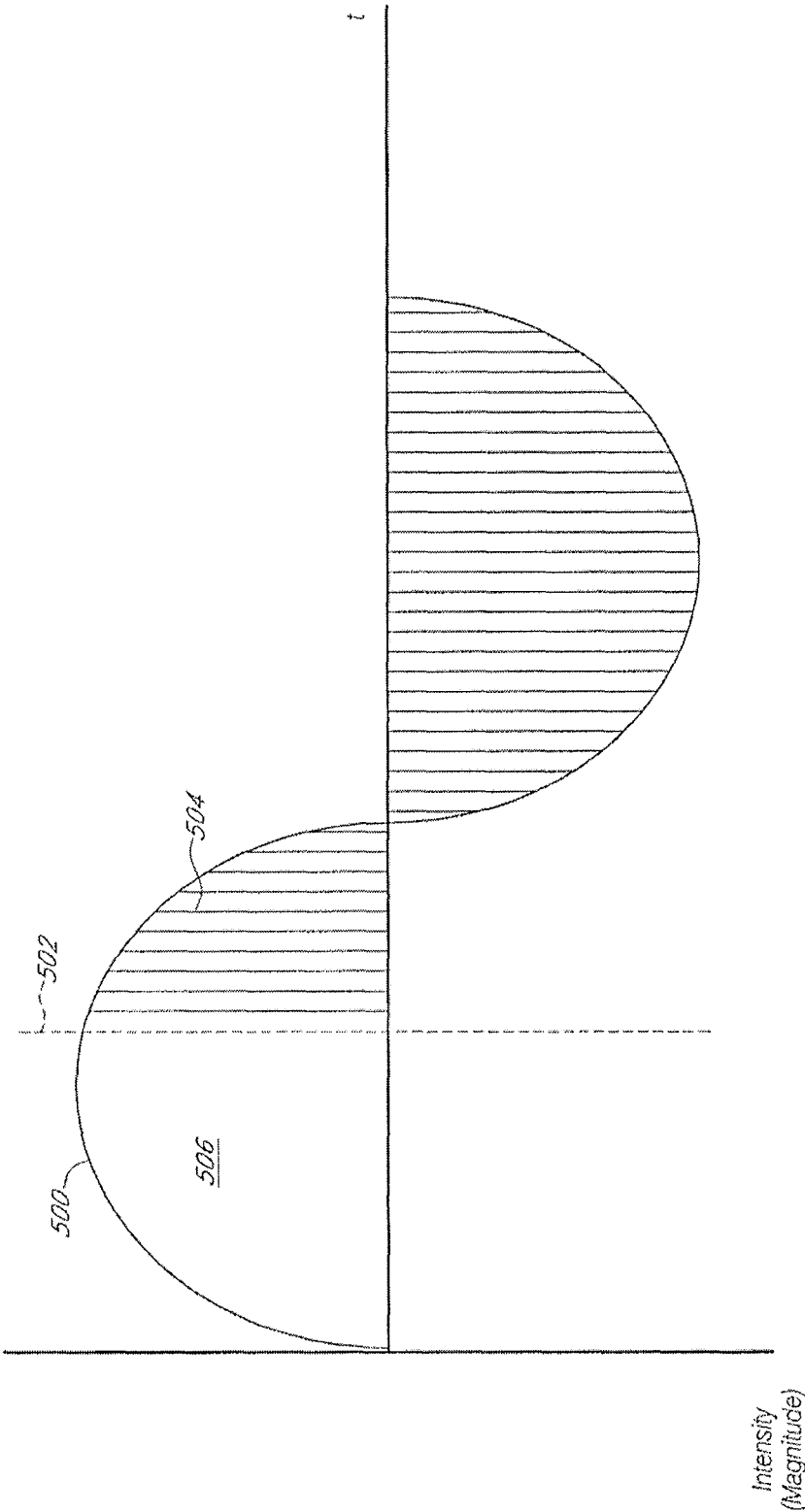

FIG. 16

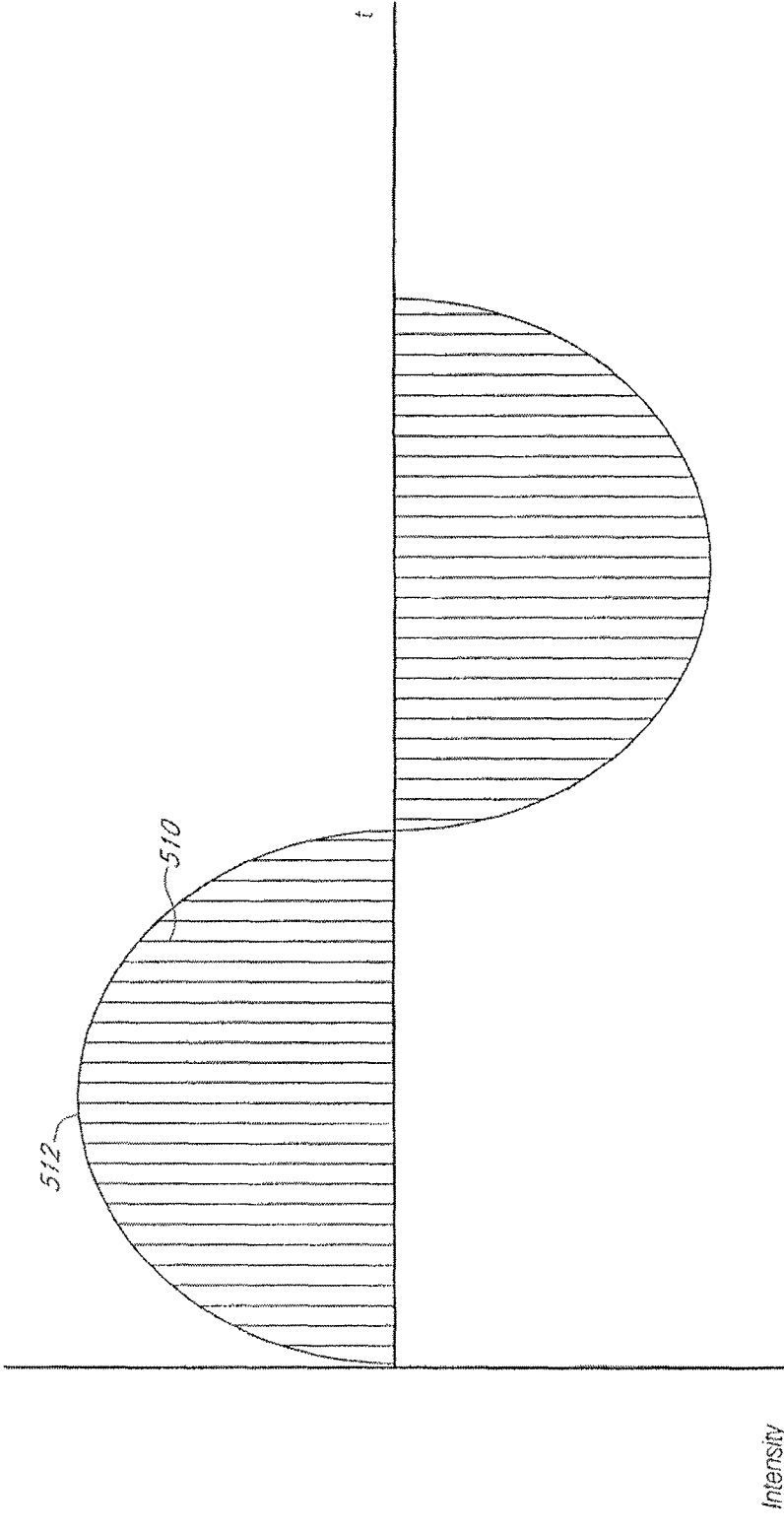

FIG. 17

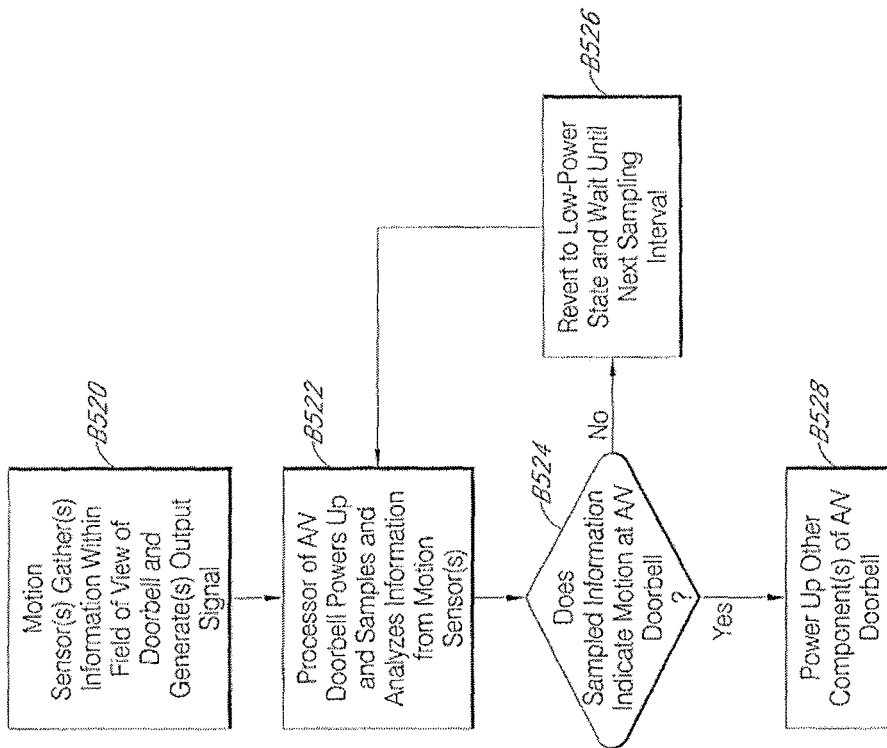

FIG. 18

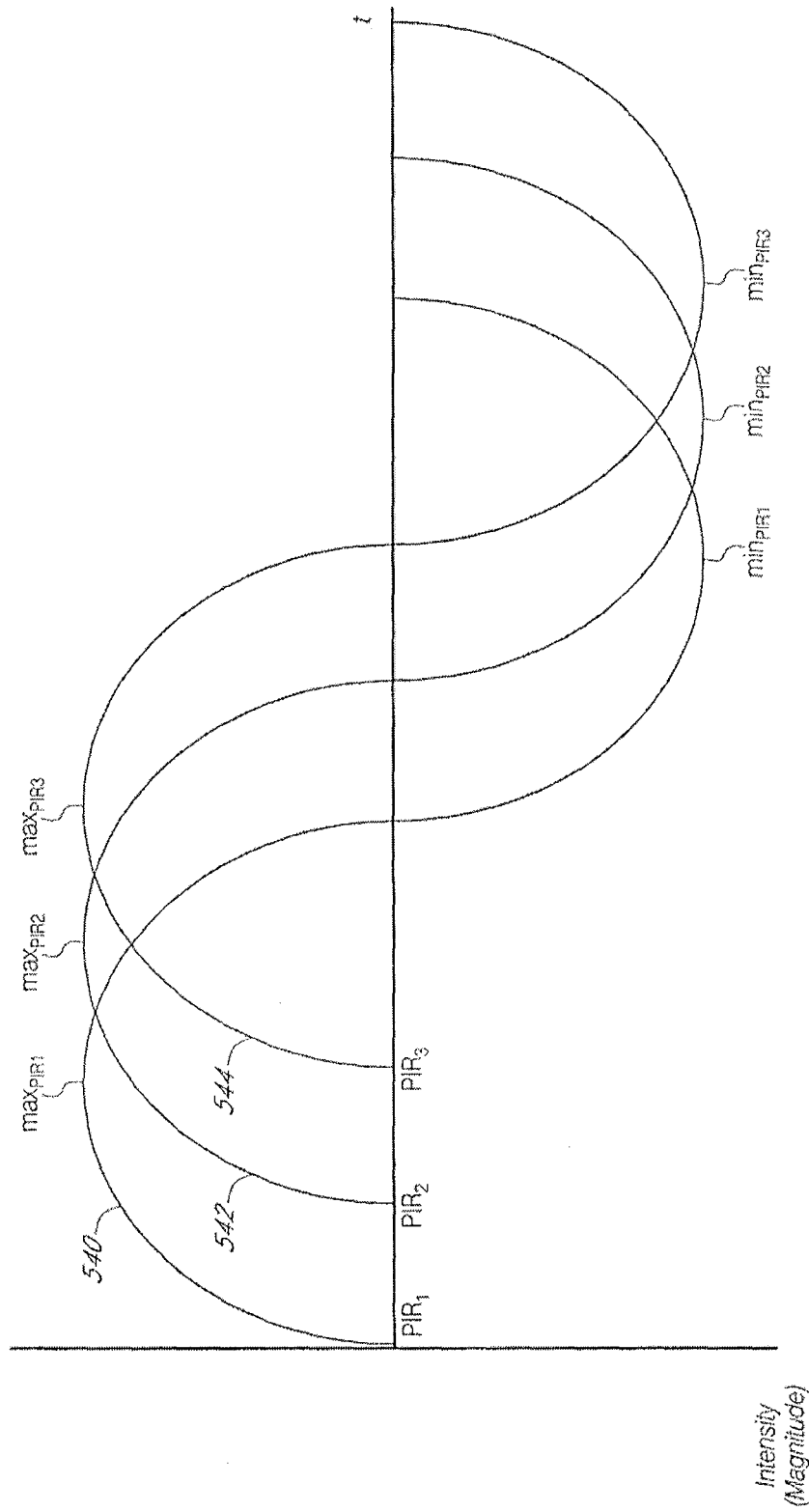

FIG. 19

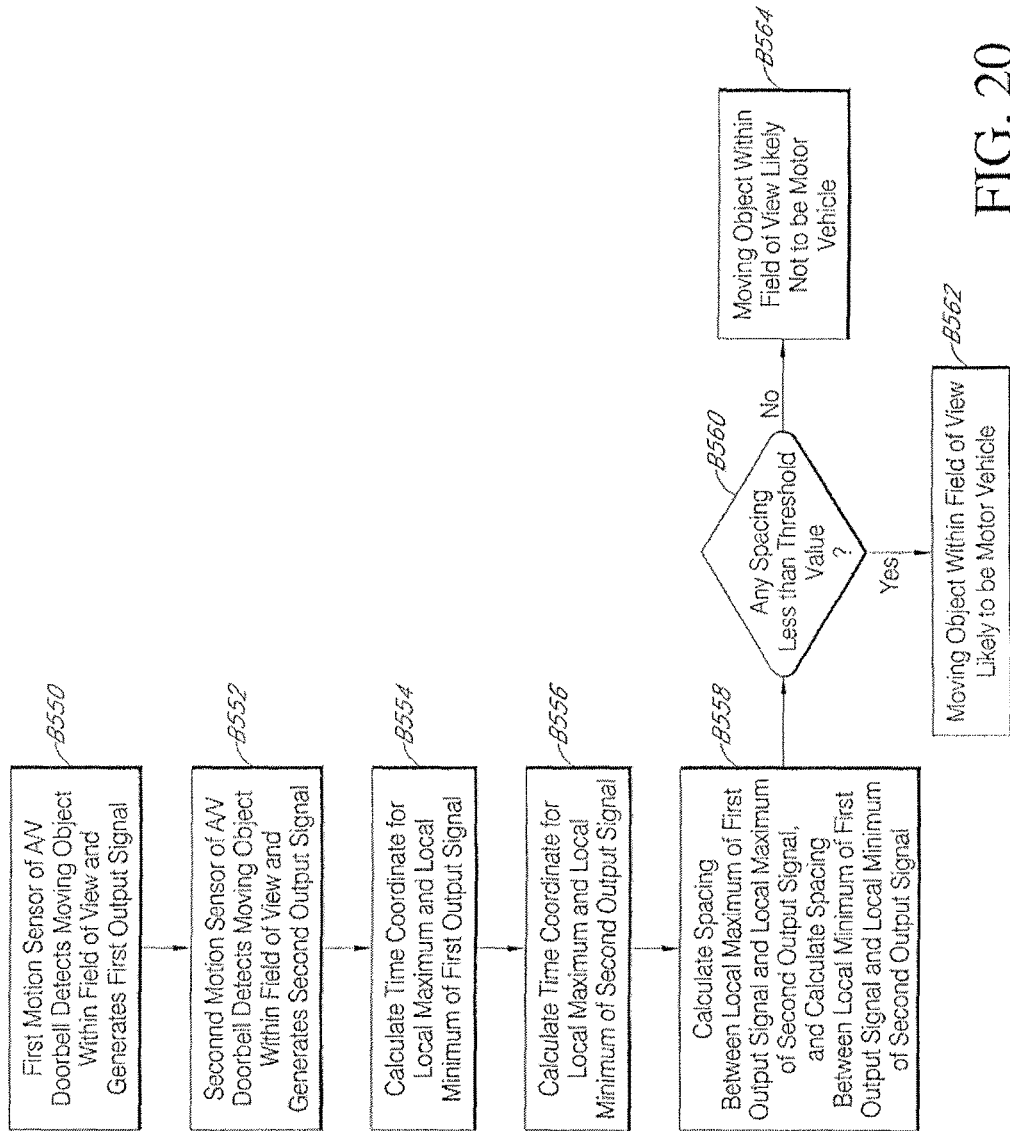

FIG. 20

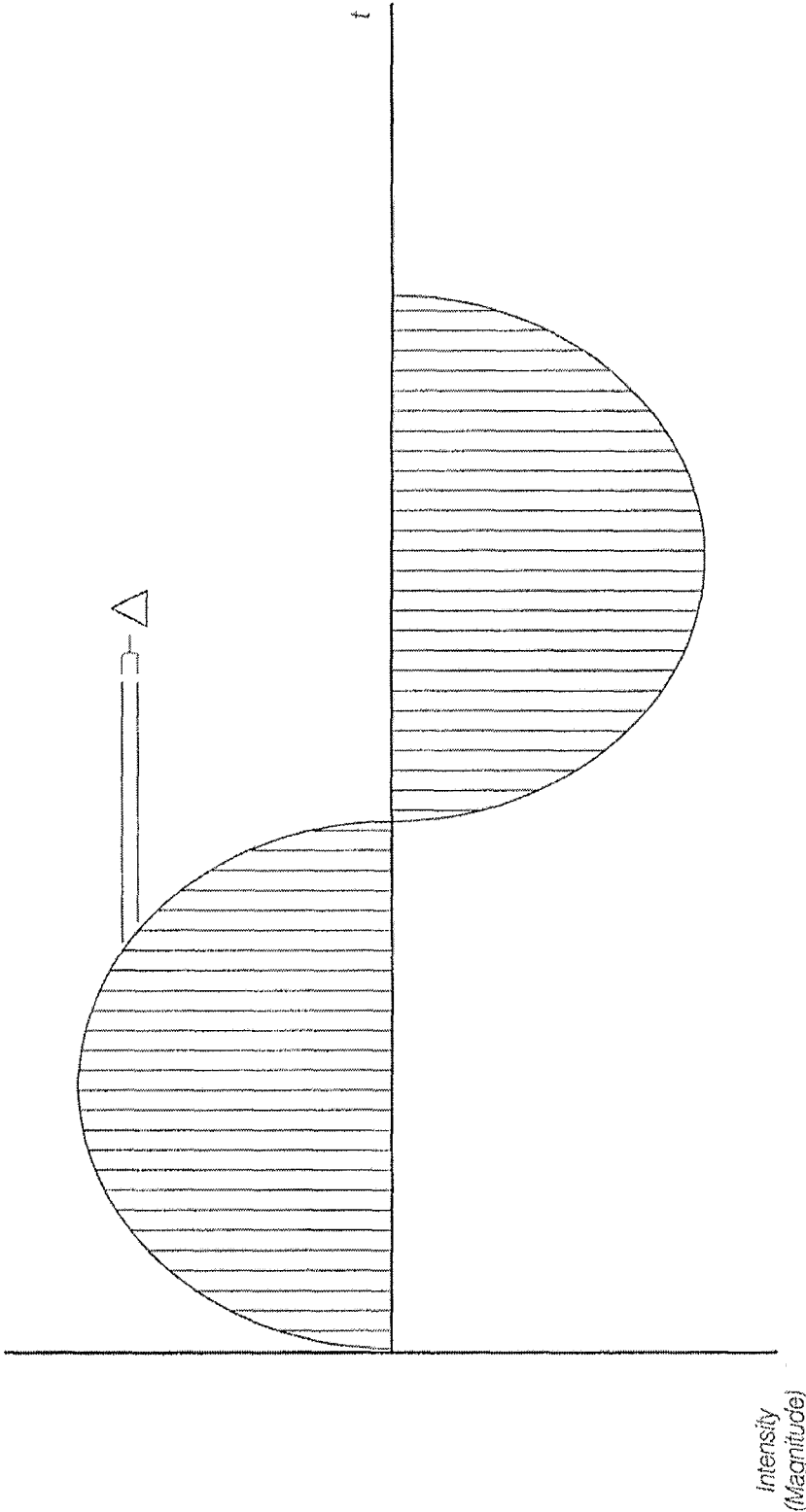

FIG. 21



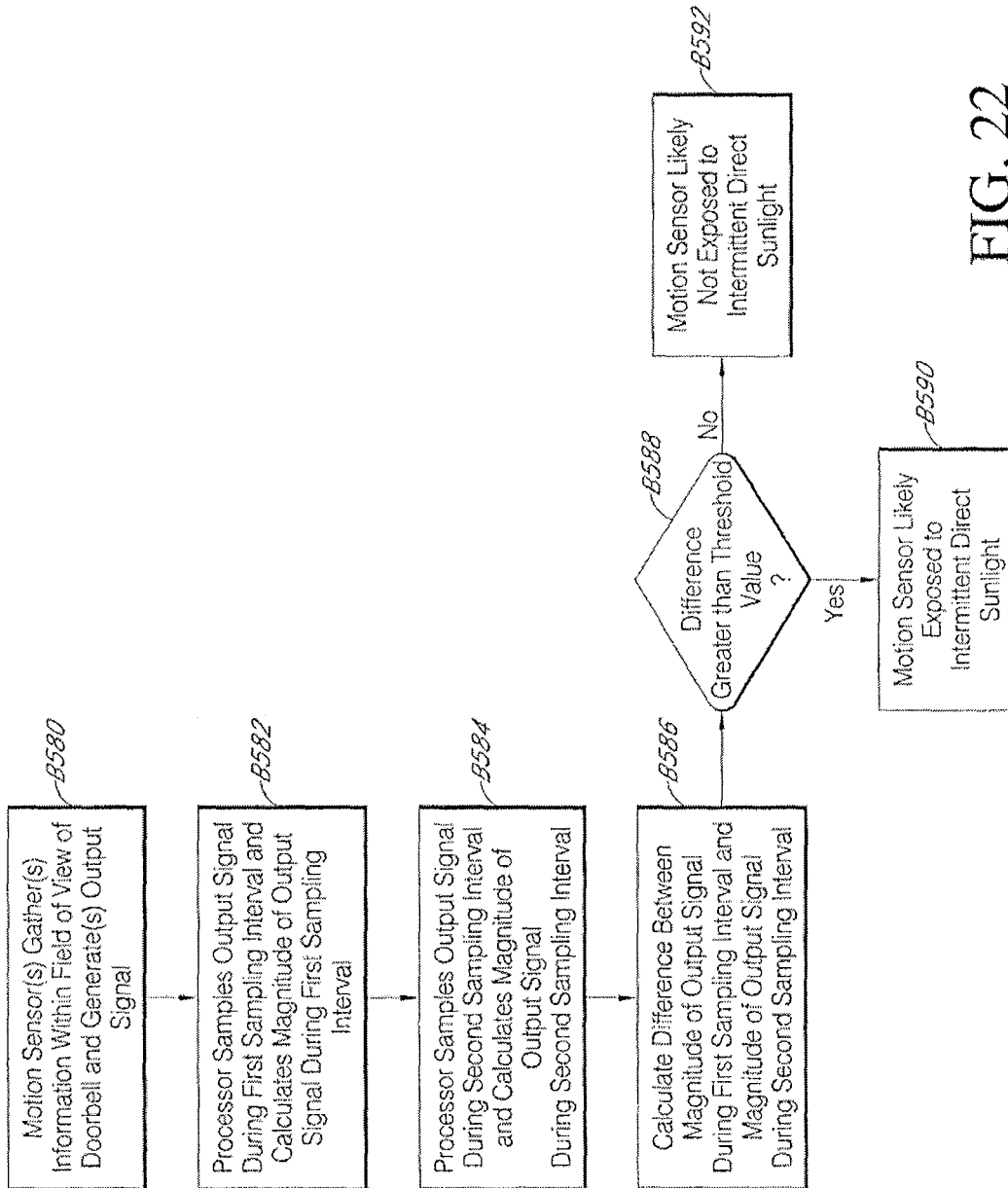

FIG. 22

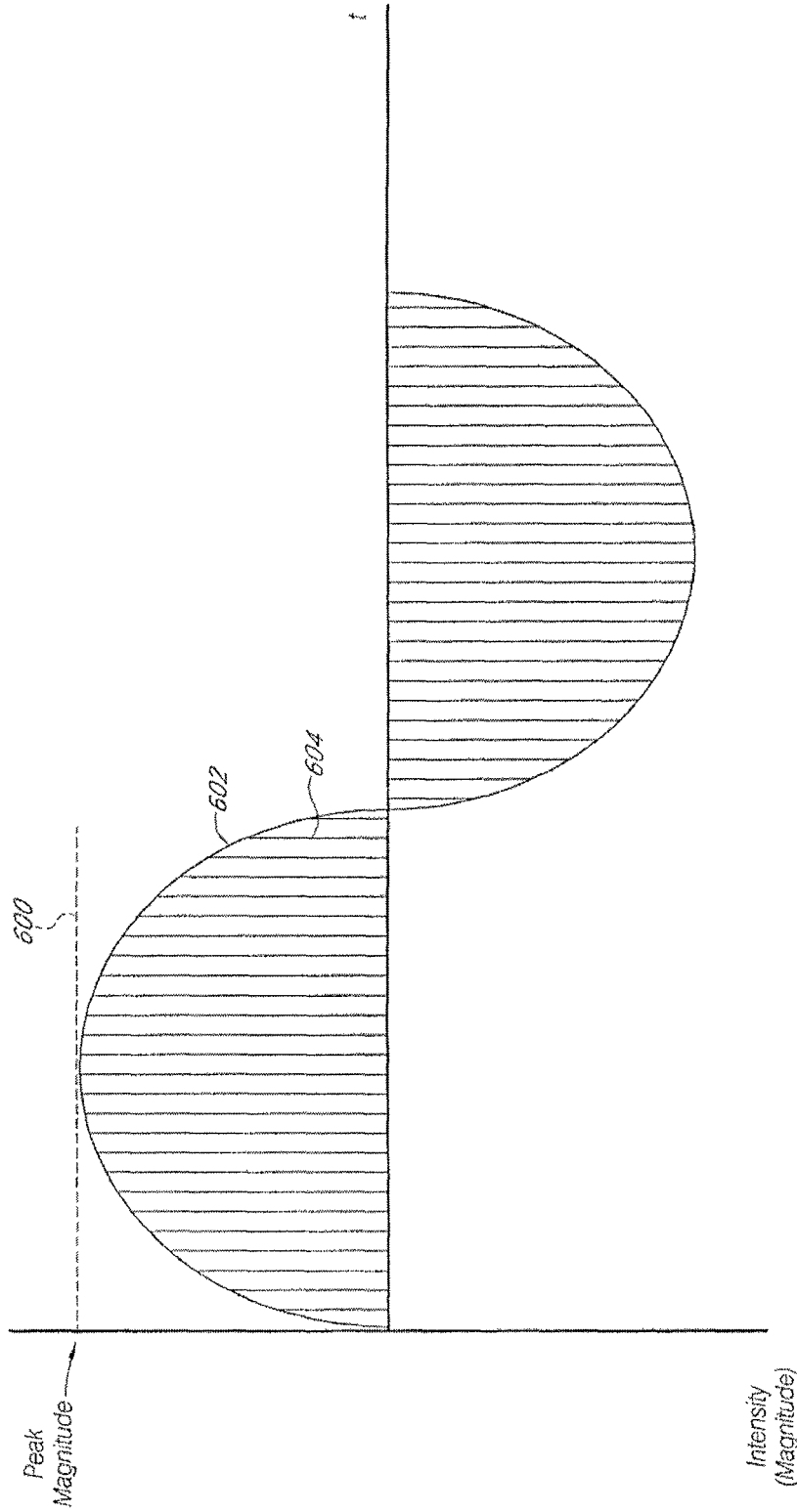

FIG. 23

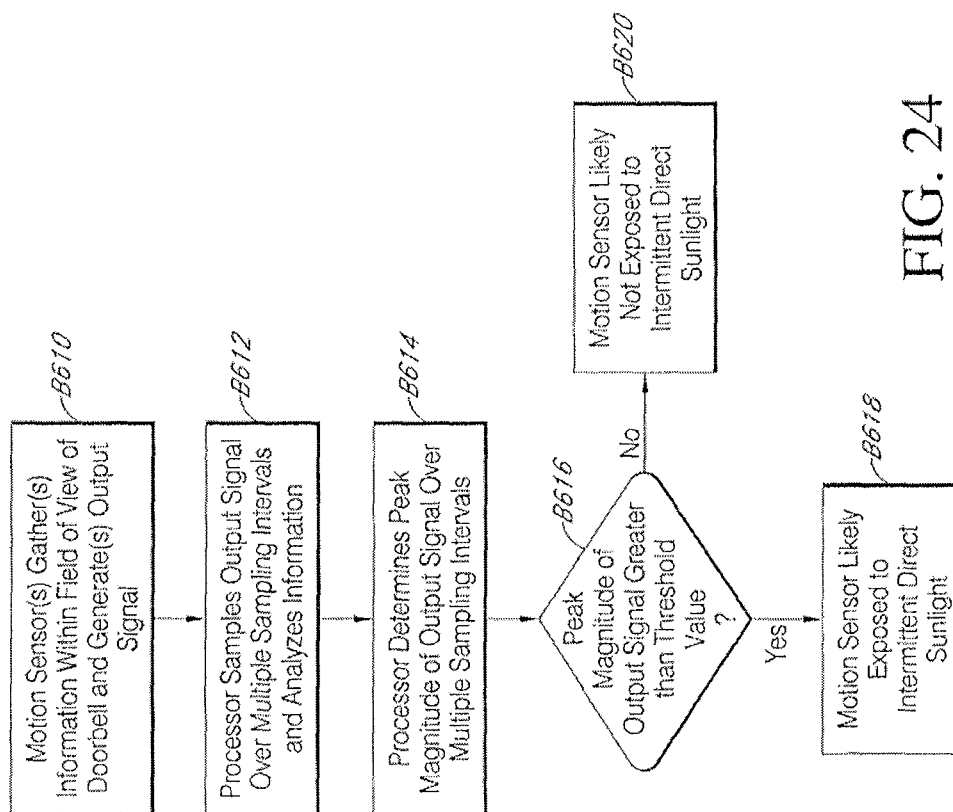

FIG. 24

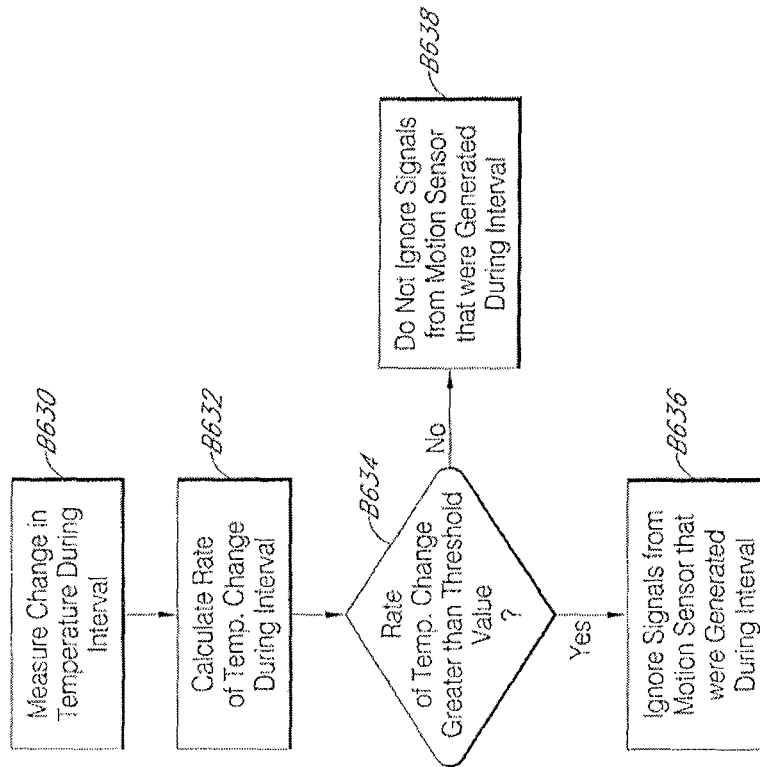

FIG. 25

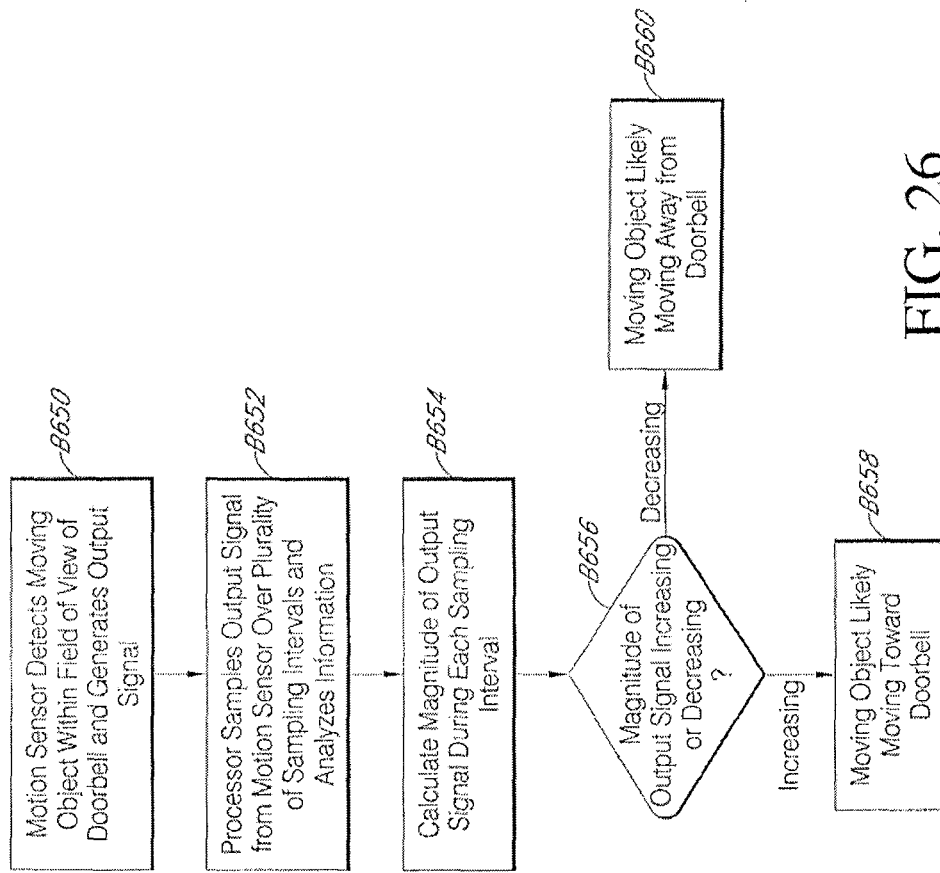

FIG. 26

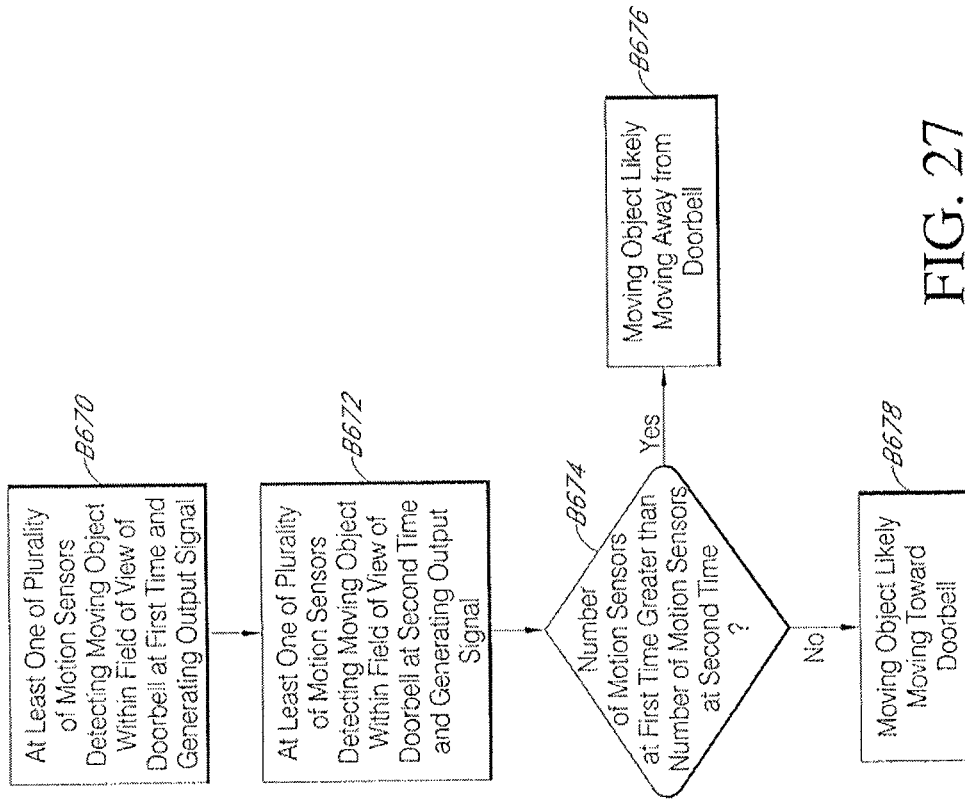

FIG. 27

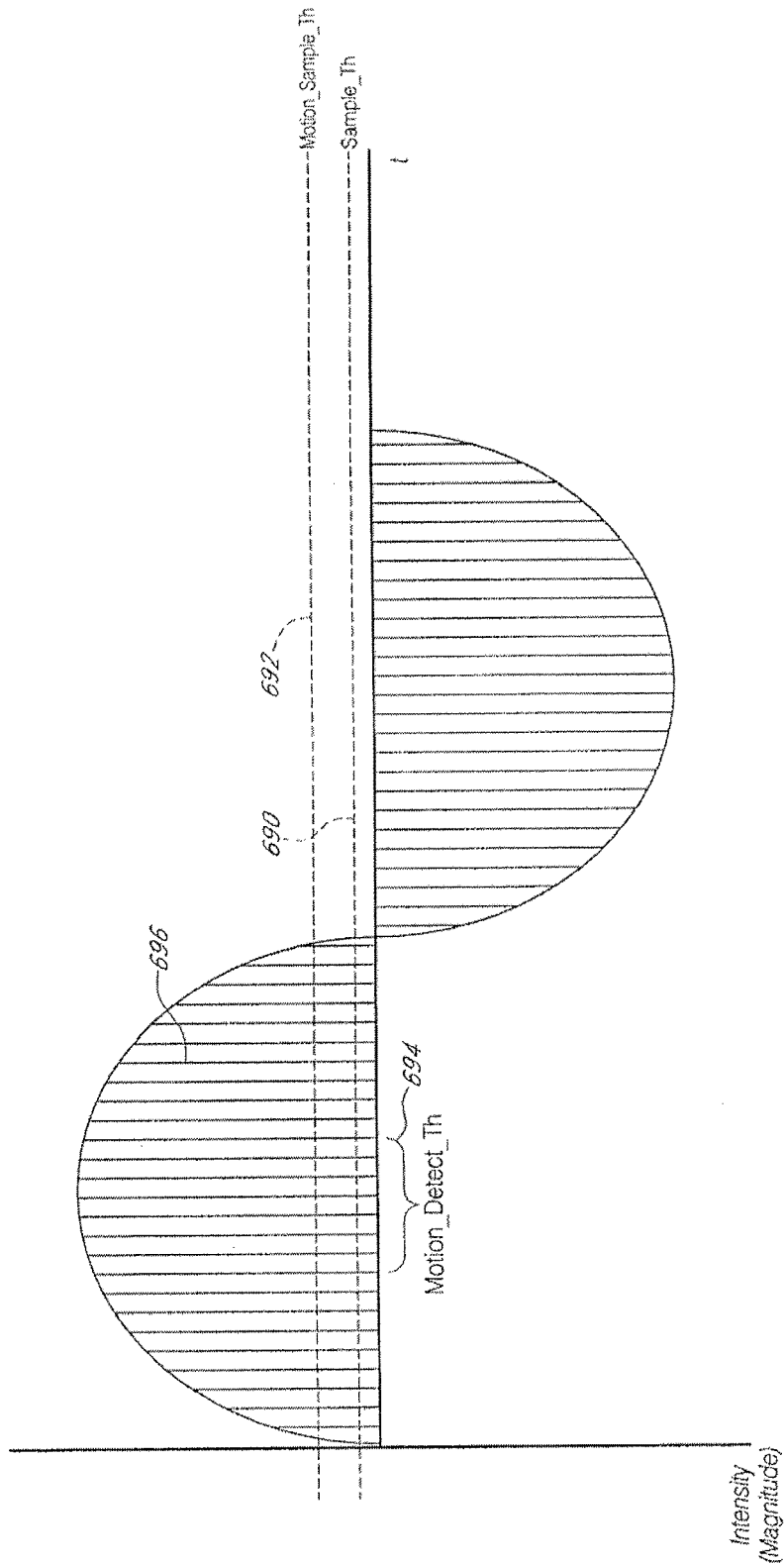

FIG. 28

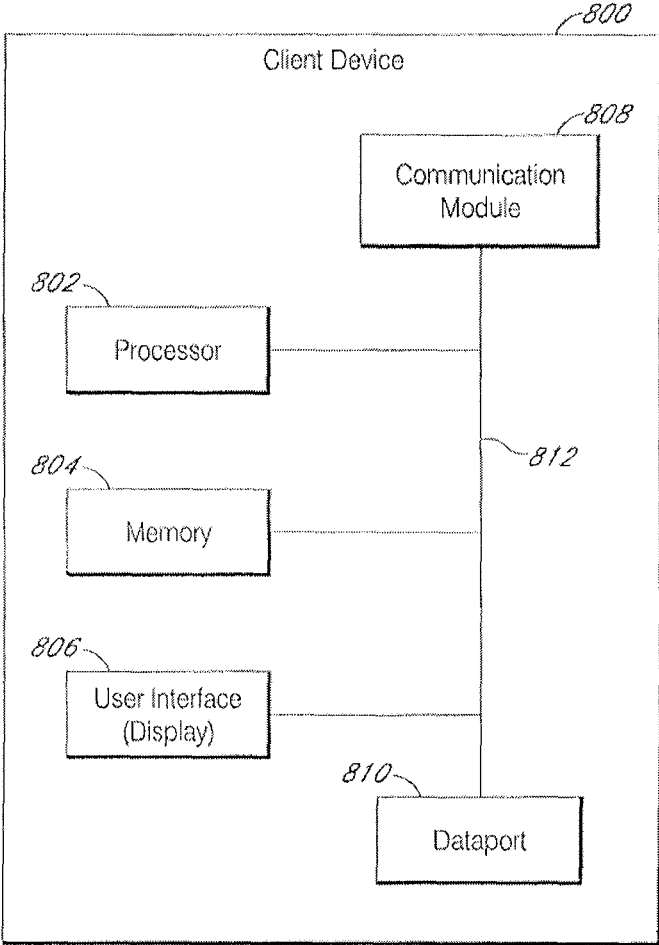

FIG. 29



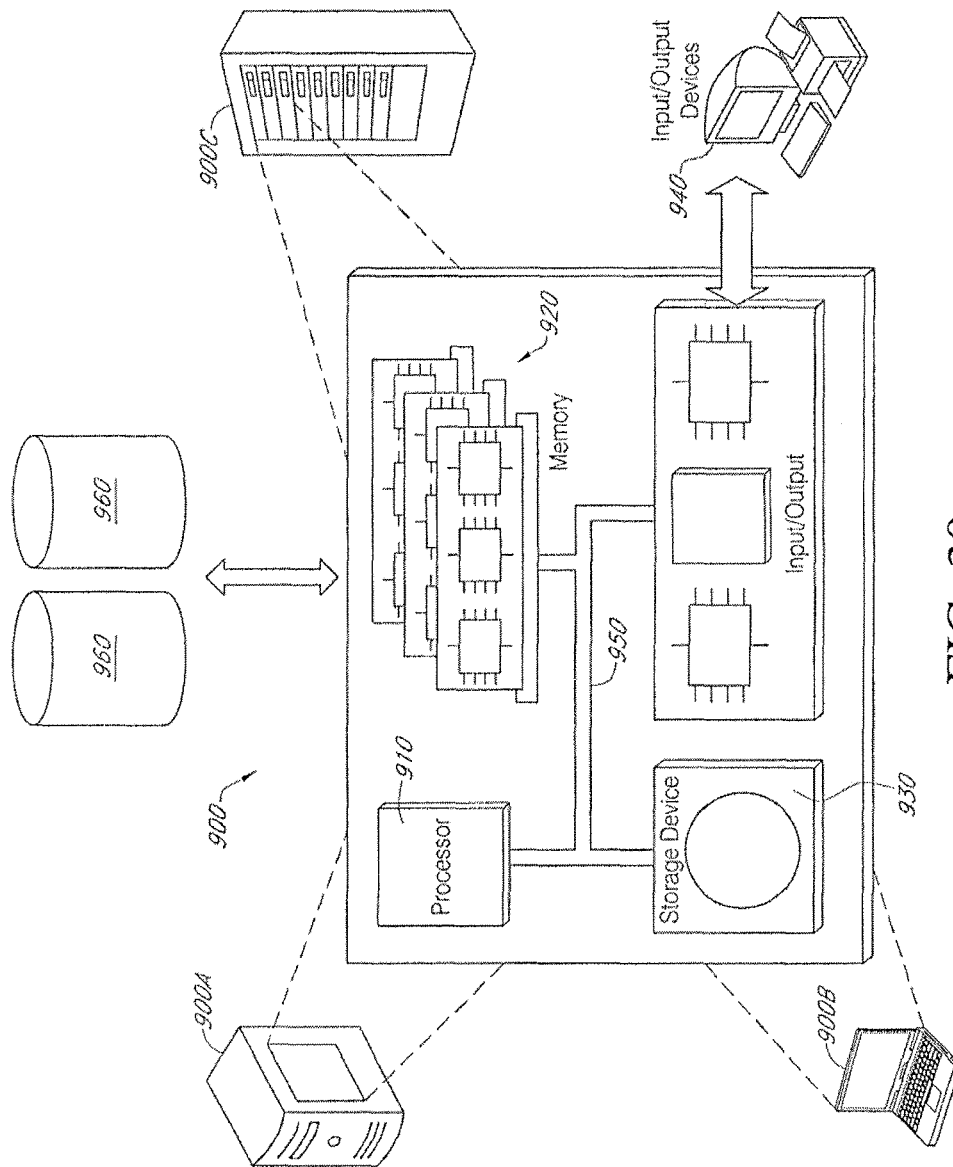

FIG. 30

1

## MOTION DETECTION FOR A/V RECORDING AND COMMUNICATION DEVICES

### CROSS-REFERENCE TO RELATED APPLICATIONS

This application claims priority to provisional application Ser. No. 62/289,072, filed on Jan. 29, 2016, and provisional application Ser. No. 62/263,334, filed on Dec. 4, 2015. The entire contents of the priority applications are hereby incorporated by reference as if fully set forth.

### TECHNICAL FIELD

The present embodiments relate to motion detection in audio/video (A/V) recording and communication devices, including A/V recording and communication doorbells. In particular, the present embodiments relate to improvements in the functionality of A/V recording and communication devices that strengthen the ability of such devices to reduce crime and enhance public safety.

### BACKGROUND

Home safety is a concern for many homeowners and renters. Those seeking to protect or monitor their homes often wish to have video and audio communications with visitors, for example, those visiting an external door or entryway. Audio/Video (A/V) recording and communication devices, such as doorbells, provide this functionality, and can also aid in crime detection and prevention. For example, audio and/or video captured by an A/V recording and communication device can be uploaded to the cloud and recorded on a remote server. Subsequent review of the A/V footage can aid law enforcement in capturing perpetrators of home burglaries and other crimes. Further, the presence of one or more A/V recording and communication devices on the exterior of a home, such as a doorbell unit at the entrance to the home, acts as a powerful deterrent against would-be burglars.

### SUMMARY

The various embodiments of the present apparatus, systems, and methods for motion detection for audio/video (A/V) recording and communication devices have several features, no single one of which is solely responsible for their desirable attributes. Without limiting the scope of the present embodiments as expressed by the claims that follow, their more prominent features now will be discussed briefly. After considering this discussion, and particularly after reading the section entitled "Detailed Description," one will understand how the features of the present embodiments provide the advantages described herein.

In a first aspect, a method for an audio/video (A/V) recording and communication device is provided, wherein the A/V recording and communication device includes a processor, a motion sensor, and a camera, the method comprising the motion sensor gathering information from within a field of view of the A/V recording and communication device and generating an output signal; the processor transitioning, at a beginning of a sampling interval, from a low-power state to an active state and sampling the output signal from the motion sensor; the processor analyzing the sampled output signal to determine whether motion is indicated within the field of view of the A/V recording and

2

communication device; if no motion is indicated within the field of view of the A/V recording and communication device, then the processor reverting to the low-power state; and if motion is indicated within the field of view of the A/V recording and communication device, then at least one other component of the A/V recording and communication device powering up.

In an embodiment of the first aspect, the if the processor reverts to the low-power state, then the processor waits until a next sampling interval and again transitions from the low-power state to the active state, at a beginning of the next sampling interval, and again samples the output signal from the motion sensor. Also in an embodiment of the first aspect, the at least one other component of the A/V recording and communication device comprises at least one of a Wi-Fi chip, a camera processor, and an image sensor.

In a second aspect, a method for an audio/video (A/V) recording and communication device is provided, wherein the A/V recording and communication device includes a processor, a motion sensor, and a camera, the method comprising the motion sensor gathering information from within a field of view of the A/V recording and communication device and generating an output signal; the processor continually sampling the output signal from the motion sensor at regular sampling intervals; the processor analyzing the sampled output signal to determine whether motion is indicated within the field of view of the A/V recording and communication device; and if motion is indicated within the field of view of the motion sensor, then at least one other component of the A/V recording and communication device powering up.

In an embodiment of the second aspect, the processor is in a low-power state between the sampling intervals. Also in an embodiment of the second aspect, the sampling intervals occur every 15.625 ms. Also in an embodiment of the second aspect, the at least one other component of the A/V recording and communication device comprises at least one of a Wi-Fi chip, a camera processor, and an image sensor.

In a third aspect, an audio/video (A/V) recording and communication device is provided, the A/V recording and communication device comprising a processor; a motion sensor; and a camera; wherein the motion sensor is configured to gather information from within a field of view of the A/V recording and communication device and to generate an output signal based on the gathered information; wherein the processor is configured to transition, at a beginning of a sampling interval, from a low-power state to an active state, and to sample the output signal from the motion sensor; and wherein the processor is further configured to analyze the sampled output signal to determine whether motion is indicated within the field of view of the A/V recording and communication device, and if no motion is indicated within the field of view of the A/V recording and communication device, then the processor is configured to revert to the low-power state, and if motion is indicated within the field of view of the A/V recording and communication device, then at least one other component of the A/V recording and communication device is configured to power up.

In a fourth aspect, an audio/video (A/V) recording and communication device is provided, the A/V recording and communication device comprising a processor; a motion sensor; and a camera; wherein the motion sensor is configured to gather information from within a field of view of the A/V recording and communication device and to generate an output signal based on the gathered information; wherein the processor is configured to continually sample the output signal from the motion sensor at regular sampling intervals;

3

and wherein the processor is further configured to analyze the sampled output signal to determine whether motion is indicated within the field of view of the A/V recording and communication device, and if motion is indicated within the field of view of the motion sensor, then at least one other component of the A/V recording and communication device is configured to power up.

In a fifth aspect, a method for an audio/video (A/V) recording and communication device is provided, wherein the A/V recording and communication device includes at least a first and a second motion sensor, the method comprising the first motion sensor detecting a moving object within a field of view of the A/V recording and communication device and generating a first output signal; the second motion sensor detecting the moving object within the field of view of the A/V recording and communication device and generating a second output signal; calculating a time coordinate for a maximum of the first output signal; calculating a time coordinate for a maximum of the second output signal; calculating a spacing between the maximum of the first output signal and the maximum of the second output signal; comparing the spacing between the maximum of the first output signal and the maximum of the second output signal to a threshold value; and if the spacing is less than the threshold value, then determining that the moving object within the field of view of the A/V recording and communication device is likely to be a motor vehicle.

In an embodiment of the fifth aspect, the A/V recording and communication device further includes a processor, and wherein the calculating steps and the comparing step are performed by the processor.

In another embodiment of the fifth aspect, the first motion sensor comprises at least a first passive infrared (PIR) sensor and the second motion sensor comprises at least a second PIR sensor.

In another embodiment of the fifth aspect, the first motion sensor comprises a first field of view and the second motion sensor comprises a second field of view.

In another embodiment of the fifth aspect, the first field of view includes a first portion that does not overlap with the second field of view.

In another embodiment of the fifth aspect, the second field of view includes a second portion that does not overlap with the first field of view.

In a sixth aspect, a method for an audio/video (A/V) recording and communication device is provided, wherein the A/V recording and communication device includes at least a first and a second motion sensor, the method comprising the first motion sensor detecting a moving object within a field of view of the A/V recording and communication device and generating a first output signal; the second motion sensor detecting the moving object within the field of view of the A/V recording and communication device and generating a second output signal; calculating a time coordinate for a maximum of the first output signal; calculating a time coordinate for a maximum of the second output signal; calculating a spacing between the maximum of the first output signal and the maximum of the second output signal; comparing the spacing between the maximum of the first output signal and the maximum of the second output signal to a threshold value; calculating a time coordinate for a minimum of the first output signal; calculating a time coordinate for a minimum of the second output signal; calculating a spacing between the minimum of the first output signal and the minimum of the second output signal; comparing the spacing between the minimum of the first output signal and the minimum of the second output signal

4

to the threshold value; and if either the spacing between the maximum of the first output signal and the maximum of the second output signal or the spacing between the minimum of the first output signal and the minimum of the second output signal is less than the threshold value, then determining that the moving object within the field of view of the A/V recording and communication device is likely to be a motor vehicle.

In a seventh aspect, an audio/video (A/V) recording and communication device is provided, the A/V recording and communication device comprising a processor; at least a first motion sensor; and at least a second motion sensor; wherein the first motion sensor is configured to detect a moving object within a field of view of the A/V recording and communication device and to generate a first output signal; wherein the second motion sensor is configured to detect the moving object within the field of view of the A/V recording and communication device and to generate a second output signal; wherein the processor is configured to calculate a time coordinate for a maximum of the first output signal; wherein the processor is further configured to calculate a time coordinate for a maximum of the second output signal; wherein the processor is further configured to calculate a spacing between the maximum of the first output signal and the maximum of the second output signal; and wherein the processor is further configured to compare the spacing between the maximum of the first output signal and the maximum of the second output signal to a threshold value, and if the spacing is less than the threshold value, then the processor is further configured to determine that the moving object within the field of view of the A/V recording and communication device is likely to be a motor vehicle.

In an embodiment of the seventh aspect, the first motion sensor comprises at least a first passive infrared (PIR) sensor and the second motion sensor comprises at least a second PIR sensor.

In another embodiment of the seventh aspect, the first motion sensor comprises a first field of view and the second motion sensor comprises a second field of view.

In another embodiment of the seventh aspect, the first field of view includes a first portion that does not overlap with the second field of view.

In another embodiment of the seventh aspect, the second field of view includes a second portion that does not overlap with the first field of view.

In an eighth aspect, an audio/video (A/V) recording and communication device is provided, the A/V recording and communication device comprising a processor; at least a first motion sensor; and at least a second motion sensor; wherein the first motion sensor is configured to detect a moving object within a field of view of the A/V recording and communication device and to generate a first output signal; wherein the second motion sensor is configured to detect the moving object within the field of view of the A/V recording and communication device and to generate a second output signal; wherein the processor is configured to calculate a time coordinate for a maximum of the first output signal; wherein the processor is further configured to calculate a time coordinate for a maximum of the second output signal; wherein the processor is further configured to calculate a spacing between the maximum of the first output signal and the maximum of the second output signal; wherein the processor is further configured to compare the spacing between the maximum of the first output signal and the maximum of the second output signal to a threshold value; wherein the processor is further configured to calculate a time coordinate for a minimum of the first output

5

signal; wherein the processor is further configured to calculate a time coordinate for a minimum of the second output signal; wherein the processor is further configured to calculate a spacing between the minimum of the first output signal and the minimum of the second output signal; wherein the processor is further configured to compare the spacing between the minimum of the first output signal and the minimum of the second output signal to a threshold value; and if either the spacing between the maximum of the first output signal and the maximum of the second output signal or the spacing between the minimum of the first output signal and the minimum of the second output signal is less than the threshold value, then the processor is further configured to determine that the moving object within the field of view of the A/V recording and communication device is likely to be a motor vehicle.

In an embodiment of the eighth aspect, the first motion sensor comprises at least a first passive infrared (PIR) sensor and the second motion sensor comprises at least a second PIR sensor.

In another embodiment of the eighth aspect, the first motion sensor comprises a first field of view and the second motion sensor comprises a second field of view.

In another embodiment of the eighth aspect, the first field of view includes a first portion that does not overlap with the second field of view.

In another embodiment of the eighth aspect, the second field of view includes a second portion that does not overlap with the first field of view.

In a ninth aspect, a method for an audio/video (A/V) recording and communication device is provided, wherein the A/V recording and communication device includes a processor and a motion sensor, the method comprising the motion sensor gathering information within a field of view of the A/V recording and communication device and generating an output signal; the processor sampling the output signal from the motion sensor during a first sampling interval; calculating a magnitude of the output signal during the first sampling interval; the processor sampling the output signal from the motion sensor during a second sampling interval; calculating a magnitude of the output signal during the second sampling interval; calculating a difference between the magnitude of the output signal during the first sampling interval and the magnitude of the output signal during the second sampling interval to a threshold value; and if the difference between the magnitude of the output signal during the first sampling interval and the magnitude of the output signal during the second sampling interval is greater than the threshold value, then determining that the motion sensor is likely exposed to intermittent direct sunlight.

In an embodiment of the ninth aspect, the calculating steps and the comparing step are performed by the processor.

In another embodiment of the ninth aspect, the motion sensor comprises at least one passive infrared (PIR) sensor.

In another embodiment of the ninth aspect, calculating the difference between the magnitude of the output signal during the first sampling interval and the magnitude of the output signal during the second sampling interval determines a rate of change of the output signal from the motion sensor.

In another embodiment of the ninth aspect, the threshold value comprises a threshold rate of change.

6

Another embodiment of the ninth aspect further comprises determining a peak magnitude of the output signal and comparing the determined peak magnitude to a threshold peak magnitude.

In a tenth aspect, an audio/video (A/V) recording and communication device is provided, the A/V recording and communication device comprising a processor; and a motion sensor; wherein the motion sensor is configured to gather information from within a field of view of the A/V recording and communication device and to generate an output signal based on the gathered information; wherein the processor is configured to sample the output signal from the motion sensor during a first sampling interval; wherein the processor is further configured to calculate a magnitude of the output signal during the first sampling interval; wherein the processor is further configured to sample the output signal from the motion sensor during a second sampling interval; wherein the processor is further configured to calculate a magnitude of the output signal during the second sampling interval; wherein the processor is further configured to calculate a difference between the magnitude of the output signal during the first sampling interval and the magnitude of the output signal during the second sampling interval; and wherein the processor is further configured to compare the difference between the magnitude of the output signal during the first sampling interval and the magnitude of the output signal during the second sampling interval to a threshold value, and, if the difference between the magnitude of the output signal during the first sampling interval and the magnitude of the output signal during the second sampling interval is greater than the threshold value, then the processor is further configured to determine that the motion sensor is likely exposed to intermittent direct sunlight.

In an embodiment of the tenth aspect, the motion sensor comprises at least one passive infrared (PIR) sensor.

In another embodiment of the tenth aspect, calculating the difference between the magnitude of the output signal during the first sampling interval and the magnitude of the output signal during the second sampling interval determines a rate of change of the output signal from the motion sensor.

In another embodiment of the tenth aspect, the threshold value comprises a threshold rate of change.

In another embodiment of the tenth aspect, the processor is further configured to determine a peak magnitude of the output signal and to compare the determined peak magnitude to a threshold peak magnitude.

In an eleventh aspect, a method for an audio/video (A/V) recording and communication device is provided, wherein the A/V recording and communication device includes a processor and a motion sensor, the method comprising the motion sensor gathering information within a field of view of the A/V recording and communication device and generating an output signal; determining a peak magnitude of the output signal; comparing the peak magnitude of the output signal to a threshold value; and if the peak magnitude of the output signal is greater than the threshold value, then determining that the motion sensor is likely exposed to intermittent direct sunlight.

In an embodiment of the eleventh aspect, the determining step and the comparing step are performed by the processor.

In a twelfth aspect, an audio/video (A/V) recording and communication device is provided, the A/V recording and communication device comprising a processor; and a motion sensor; wherein the motion sensor is configured to gather information within a field of view of the A/V recording and communication device and to generate an output signal based on the gathered information; wherein the processor is

configured to determine a peak magnitude of the output signal; and wherein the processor is further configured to compare the peak magnitude of the output signal to a threshold value, and if the peak magnitude of the output signal is greater than the threshold value, then the processor is further configured to determine that the motion sensor is likely exposed to intermittent direct sunlight.

In an embodiment of the twelfth aspect, the motion sensor comprises at least one passive infrared (PIR) sensor.

In another embodiment of the twelfth aspect, determining the peak magnitude of the output signal comprises the processor sampling the output signal of the motion sensor over multiple sampling intervals.

In another embodiment of the twelfth aspect, the processor is further configured to determine a rate of change of the output signal from the motion sensor and to compare the determined rate of change to a threshold rate of change.

In a thirteenth aspect, a method for an audio/video A/V recording and communication device is provided, wherein the A/V recording and communication device includes a processor, a motion sensor, and a temperature sensor, the method comprising the temperature sensor measuring a change in temperature during an interval; calculating a rate of change in the temperature during the interval; comparing the rate of change in the temperature during the interval to a threshold value; and if the rate of change in the temperature during the interval is greater than the threshold value, then ignoring any signals from the motion sensor that were generated during the interval.

In an embodiment of the thirteenth aspect, the calculating step and the comparing step are performed by the processor.

In another embodiment of the thirteenth aspect, the motion sensor comprises at least one passive infrared (PIR) sensor.

In another embodiment of the thirteenth aspect, the A/V recording and communication device comprises a doorbell.

In another embodiment of the thirteenth aspect, the change in temperature measured by the temperature sensor comprises a change in temperature of a battery of the A/V recording and communication device.

In another embodiment of the thirteenth aspect, the threshold value comprises 1° C./min.

In a fourteenth aspect, an audio/video (A/V) recording and communication device is provided, the A/V recording and communication device comprising a processor; a motion sensor; and a temperature sensor; wherein the temperature sensor is configured to measure a change in temperature during an interval; wherein the processor is configured to calculate a rate of change in the temperature during the interval; and wherein the processor is further configured to compare the rate of change in the temperature during the interval to a threshold value, and if the rate of change in the temperature during the interval is greater than the threshold value, then the processor is further configured to ignore any signals from the motion sensor that were generated during the interval.

In an embodiment of the fourteenth aspect, the motion sensor comprises at least one passive infrared (PIR) sensor.

In another embodiment of the fourteenth aspect, the A/V recording and communication device comprises a doorbell.

In another embodiment of the fourteenth aspect, the change in temperature measured by the temperature sensor comprises a change in temperature of a battery of the A/V recording and communication device.

In another embodiment of the fourteenth aspect, the threshold value comprises 1° C./min.

In a fifteenth aspect, a method for an audio/video (A/V) recording and communication device is provided, wherein the A/V recording and communication device includes a processor and a motion sensor, the method comprising the motion sensor detecting a moving object within a field of view of the A/V recording and communication device and generating an output signal; the processor sampling the output signal from the motion sensor over a plurality of sampling intervals; calculating a magnitude of the output signal during each of the sampling intervals; determining whether the magnitude of the output signal is increasing or decreasing over the plurality of sampling intervals; if the magnitude of the output signal is increasing over the plurality of sampling intervals, then determining that the moving object is likely moving toward the A/V recording and communication device; and if the magnitude of the output signal is decreasing over the plurality of sampling intervals, then determining that the moving object is likely moving away from the A/V recording and communication device.

In an embodiment of the fifteenth aspect, the calculating steps and the determining step are performed by the processor.

In another embodiment of the fifteenth aspect, the motion sensor comprises at least one passive infrared (PIR) sensor.

Another embodiment of the fifteenth aspect further comprises, when it is determined that the moving object is likely moving toward the A/V recording and communication device, then generating a user alert.

Another embodiment of the fifteenth aspect further comprises, when it is determined that the moving object is likely moving away from the A/V recording and communication device, then not generating a user alert.

In a sixteenth aspect, an audio/video (A/V) recording and communication device is provided, the A/V recording and communication device comprising a processor; and a motion sensor; wherein the motion sensor is configured to detect a moving object within a field of view of the A/V recording and communication device and to generate an output signal; wherein the processor is configured to sample the output signal from the motion sensor over a plurality of sampling intervals; wherein the processor is further configured to calculate a magnitude of the output signal during each of the sampling intervals; and wherein the processor is further configured to determine whether the magnitude of the output signal is increasing or decreasing over the plurality of sampling intervals, and if the magnitude of the output signal is increasing over the plurality of sampling intervals, then the processor is further configured to determine that the moving object is likely moving toward the A/V recording and communication device, and if the magnitude of the output signal is decreasing over the plurality of sampling intervals, then the processor is further configured to determine that the moving object is likely moving away from the A/V recording and communication device.

In an embodiment of the sixteenth aspect, the motion sensor comprises at least one passive infrared (PIR) sensor.

In another embodiment of the sixteenth aspect, the processor is further configured to generate a user alert when it is determined that the moving object is likely moving toward the A/V recording and communication device.

In another embodiment of the sixteenth aspect, the processor is further configured to not generate a user alert when it is determined that the moving object is likely moving toward the A/V recording and communication device.

In a seventeenth aspect, a method for an audio/video (A/V) recording and communication device is provided, wherein the A/V recording and communication device

includes a processor and is plurality of motion sensors, the method comprising at least one of the motion sensors detecting, at a first time, a moving object within a field of view of the A/V recording and communication device; at least one of the motion sensors detecting, at a second time, the moving object within the field of view of the A/V recording and communication device; comparing a first number of the motion sensors that detected the moving object within the field of view of the A/V recording and communication device at the first time and a second number of the motion sensors that detected the moving object within the field of view of the A/V recording and communication device at the second time; if the first number is less than the second number, then determining that the moving object is likely moving toward the A/V recording and communication device; and if the first number is greater than the second number, then determining that the moving object is likely moving away from the A/V recording and communication device.

In an embodiment of the seventeenth aspect, the comparing step is performed by the processor.

In an eighteenth aspect, an audio/video (A/V) recording and communication device is provided, the A/V recording and communication device comprising a processor; and a plurality of motion sensors; wherein at least one of the motion sensors is configured to detect, at a first time, a moving object within a field of view of the A/V recording and communication device; wherein at least one of the motion sensors is configured to detect, at a second time, the moving object within the field of view of the A/V recording and communication device; wherein the processor is configured to compare a first number of the motion sensors that detected the moving object within the field of view of the A/V recording and communication device at the first time and a second number of the motion sensors that detected the moving object within the field of view of the A/V recording and communication device at the second time, and if the first number is less than the second number, then the processor is further configured to determine that the moving object is likely moving toward the A/V recording and communication device, and if the first number is greater than the second number, then the processor is further configured to determine that the moving object is likely moving away from the A/V recording and communication device.

In an embodiment of the eighteenth aspect, the motion sensors comprise passive infrared (PIR) sensors.

In another embodiment of the eighteenth aspect, the processor is further configured to generate a user alert when it is determined that the moving object is likely moving toward the A/V recording and communication device.

In another embodiment of the eighteenth aspect, the processor is further configured to not generate a user alert when it is determined that the moving object is likely moving toward the A/V recording and communication device.

In a nineteenth aspect, a method for all audio/video (A/V) recording and communication device is provided, the A/V recording and communication device including a processor, a motion sensor, and a camera, the method comprising the motion sensor gathering information from within a field of view of the motion sensor and generating an output signal, the processor continually sampling the output signal from the motion sensor at regular sampling intervals, wherein the processor is in a low-power state between the sampling intervals, and wherein the processor transitions, at a beginning of each sampling interval, from a low-power state to an active state without receiving an interrupt signal from the

motion sensor, the processor an the sampled output signal to determine whether motion is indicated within the field of view of the motion sensor, and when motion is indicated within the field of view of the motion sensor, then at least one other component of the A/V recording and communication device powering up.

In an embodiment of the nineteenth aspect, the sampling intervals occur every 15.625 ms.

In another embodiment of the nineteenth aspect, the at least one other component of the A/V recording and communication device comprises at least one of a Wi-Fi chip, a camera processor, and an image sensor.

In another embodiment of the nineteenth aspect, the motion sensor comprises at least one passive infrared (PIR) sensor.

In another embodiment of the nineteenth aspect, when motion is indicated within the field of view of the motion sensor, then the processor generates a signal to power up the at least one other component of the A/V recording and communication device, and the at least one other component of the A/V recording and communication device powers up in response to the signal from the processor.

In a twentieth aspect, an audio/video (A/V) recording and communication device is provided, comprising a processor, a motion sensor, and a camera, wherein the motion sensor is configured to gather information from within a field of view of the motion sensor and to generate an output signal based on the gathered information, wherein the processor is configured to continually sample the output signal from the motion sensor at regular sampling intervals, wherein the processor is in a low-power state between the sampling intervals, and wherein the processor transitions, at a beginning of each sampling interval, from a low-power state to an active state without receiving an interrupt signal from the motion sensor, and wherein the processor is further configured to analyze the sampled output signal to determine whether motion is indicated within the field of view of the motion sensor, and when motion is indicated within the field of view of the motion sensor, then at least one other component of the A/V recording and communication device is configured to power up.

In an embodiment of the twentieth aspect, the sampling intervals occur every 15.625 ms.

In another embodiment of the twentieth aspect, the at least one other component of the A/V recording and communication device comprises at least one of a Wi-Fi chip, a camera processor, and an image sensor.

In another embodiment of the twentieth aspect, the motion sensor comprises at least one passive infrared (PIR) sensor.

In another embodiment of the twentieth aspect, when motion is indicated within the field of view of the motion sensor, then the processor is further configured to generate a signal to power up the at least one other component of the A/V recording and communication device, and the at least one other component of the A/V recording and communication device is further configured to power up in response to the signal from the processor.

In a twenty-first aspect, an audio/video (A/V) recording and communication device is provided, comprising a processor, a motion sensor, and a camera, wherein the motion sensor is configured to gather information from within a field of view of the motion sensor and to generate to output signal based on the gathered information wherein the processor is configured to transition, at a beginning of a sampling interval, from a low-power state to an active state without receiving an interrupt signal from the motion sensor,

## 11

and the processor in the active state is configured to sample the output signal from the motion sensor, and wherein the processor is further configured to analyze the sampled output signal to determine whether motion is indicated within the field of view of the motion sensor, and if no motion is indicated within the field of view of the motion sensor, then the processor is configured to revert to the low-power state, and if motion is indicated within the field of view of the motion sensor, then at least one other component of the A/V recording and communication device is configured to power up.

In an embodiment of the twenty-first aspect, if the processor reverts to the low-power state, then the processor is further configured to wait until a next sampling interval and again transition, at a beginning of the next sampling interval, from the low-power state to the active state without receiving an interrupt signal from the motion sensor, and again sample the output signal from the motion sensor.

In another embodiment of the twenty-first aspect, the at least one other component of the A/V recording and communication device comprises at least one of a Wi-Fi chip, a camera processor, and an image sensor.

In another embodiment of the twenty-first aspect, the motion sensor comprises at least one passive infrared (PIR) sensor.

In another embodiment of the twenty-first aspect, when motion is indicated within the field of view of the motion sensor, then the processor is further configured to generate a signal to power up the at least one other component of the A/V recording and communication device, and the at least one other component of the A/V recording and communication device is further configured to power up in response to the signal from the processor.

## BRIEF DESCRIPTION OF THE DRAWINGS

The various embodiments of the present apparatus, systems, and methods for motion detection for A/V recording and communication devices now will be discussed in detail with an emphasis on highlighting the advantageous features. These embodiments depict the novel and non obvious apparatus, systems, and methods for motion detection for A/V recording and communication devices shown in the accompanying drawings, which are for illustrative purposes only. These drawings include the following figures, in which like numerals indicate like parts:

FIG. 1 is a functional block diagram illustrating a system for streaming and storing A/V content captured by an A/V recording and communication device according to the present embodiments;

FIG. 2 is a front view of an A/V recording and communication doorbell according to an aspect of the present disclosure;

FIG. 3 is a rear view of the A/V recording and communication doorbell of FIG. 2;

FIG. 4 is a left side view of the A/V recording and communication doorbell of FIG. 2 attached to a mounting bracket according to an aspect of the present disclosure;

FIG. 5 is cross-sectional right side view of the A/V recording and communication doorbell of FIG. 2;

FIG. 6 is an exploded view of the A/V recording and communication doorbell and the mounting bracket of FIG. 4;

FIG. 7 is a rear view of the mounting bracket of FIG. 4;

FIGS. 8A and 8B are top and bottom views, respectively, of the A/V recording and communication doorbell and the mounting bracket of FIG. 4;

## 12

FIGS. 9A and 9B are top and front views, respectively, of a passive infrared sensor holder of the A/V recording and communication doorbell of FIG. 2;

FIGS. 10A and 10B are top and front views, respectively, of a passive infrared sensor holder assembly of the A/V recording and communication doorbell of FIG. 2;

FIG. 11 is a top view of the passive infrared sensor assembly of FIG. 10A and a field of view thereof according to an aspect of the present disclosure;

FIG. 12 is a functional block diagram of the components of the A/V recording and communication doorbell of FIG. 2;

FIG. 13 is a flowchart illustrating a process for an A/V recording and communication doorbell according to an aspect of the present disclosure;

FIG. 14 is a flowchart illustrating another process for an A/V recording and communication doorbell according to an aspect of the present disclosure;

FIG. 15 is a flowchart illustrating another process for an A/V recording and communication doorbell according to an aspect of the present disclosure;

FIG. 16 is a graph illustrating a process for an A/V recording and communication device according to the present embodiments;

FIG. 17 is a graph illustrating another process for an A/V recording and communication device according to the present embodiments;

FIG. 18 is a flowchart illustrating another process for an A/V recording and communication device according to an aspect of the present disclosure;

FIG. 19 is a graph illustrating another process for an A/V recording and communication device according to the present embodiments;

FIG. 20 is a flowchart illustrating another process for an A/V recording and communication device according to an aspect of the present disclosure;

FIG. 21 is a graph illustrating another process for an A/V recording and communication device according to the present embodiments;

FIG. 22 is a flowchart illustrating another process for an A/V recording and communication device according to an aspect of the present disclosure;

FIG. 23 is a graph illustrating another process for an A/V recording and communication device according to the present embodiments;

FIG. 24 is a flowchart illustrating another process for an A/V recording and communication device according to an aspect of the present disclosure;

FIG. 25 is a flowchart illustrating another process for an A/V recording and communication device according to an aspect of the present disclosure;

FIG. 26 is a flowchart illustrating another process for an A/V recording and communication device according to an aspect of the present disclosure;

FIG. 27 is a flowchart illustrating another process for an A/V recording and communication device according to an aspect of the present disclosure;

FIG. 28 is a graph illustrating another process for an A/V recording and communication device according to the present embodiments;

FIG. 29 is a functional block diagram of a client device on which the present embodiments may be implemented according to various aspects of the present disclosure; and

FIG. 30 is a functional block diagram of a general-purpose computing system on which the present embodiments may be implemented according to various aspects of the present disclosure.

The following detailed description describes the present embodiments with reference to the drawings. In the drawings, reference numbers label elements of the present 5  
embodiments. These reference numbers are reproduced below in connection with the discussion of the corresponding drawing features.

The embodiments of the present apparatus, systems, and methods for motion detection for A/V recording and communication devices are described below with reference to 10  
the figures. These figures, and their written descriptions, indicate that certain components of the apparatus are formed integrally, and certain other components are formed as separate pieces. Those of ordinary skill in the art will appreciate that components shown and described herein as being formed integrally may in alternative embodiments be formed as separate pieces. Those of ordinary skill in the art will further appreciate that components shown and described herein as being formed as separate pieces may in alternative 15  
embodiments be formed integrally. Further, as used herein the term integral describes a single unitary piece.

With reference to FIG. 1, the present embodiments include an audio/video (A/V) doorbell. While the present disclosure provides numerous examples of methods and systems including A/V recording and communication doorbells, the present embodiments are equally applicable for A/V recording and communication devices other than doorbells. For example, the present embodiments may include one or more A/V recording and communication security 20  
cameras instead of, or in addition to, one or more A/V recording and communication doorbells. An example A/V recording and communication security camera may include substantially all of the structure and functionality of the doorbells described herein, but without the front button and related components. 25

The A/V recording and communication doorbell **100** is typically located near the entrance to a structure (not shown), such as a dwelling, a business, a storage facility, etc. The A/V recording and communication doorbell **100** includes a camera **102**, a microphone **104**, and a speaker **106**. The camera **102** may comprise, for example, a high definition (HD) video camera, such as one capable of capturing video images at an image display resolution of 720p or better. While not shown, the A/V recording and communication doorbell **100** may also include other hardware and/or components, such as a housing, one or more motion sensors (and/or other types of sensors), a button, etc. The A/V recording and communication doorbell **100** may further include similar componentry and/or functionality as the wireless communication doorbells described in US Patent Application Publication Nos. 2015/0022620 (U.S. application Ser. No. 14/499,828) and 2015/0022618 (U.S. application Ser. No. 14/334,922), both of which are incorporated herein by reference in their entireties as if fully set forth. 35

With further reference to FIG. 1, the A/V recording and communication device **100** communicates with a user's network **110**, which may be for example a wired and/or wireless network. If the user's network **110** is wireless, or includes a wireless component, the network **110** may be a Wi-Fi network compatible with the IEEE 802.11 standard and/or other wireless communication standard(s). The user's network **110** is connected to another network **112**, which may comprise, for example, the Internet and/or a public switched telephone network (PSTN). As described below, 40  
the A/V recording and communication doorbell **100** may communicate with the user's client device **114** via the

network **110** and the network **112** (Internet/PSTN). The user's client device **114** may comprise, for example, a mobile telephone (may also be referred to as a cellular telephone), such as a smartphone, a personal digital assistant (PDA), or another communication device. The user's client device **114** comprises a display (not shown) and related components capable of displaying streaming and or recorded video images. The user's client device **114** may also comprise a speaker and related components capable of broadcasting streaming and/or recorded audio, and may also comprise a microphone. The A/V recording and communication doorbell **100** may also communicate with one or more remote storage device(s) **116** (may be referred to interchangeably as "cloud storage device(s)") via the network **110** and the network **112** (Internet/PSTN), one or more servers **118**, and/or a backend API (application programming interface) **120** via the user's network **110** and the network **112** (Internet/PSTN). While FIG. 1 illustrates the storage device **116**, the server **118**, and the backend API **120** as components separate from the network **112**, it is to be understood that the storage device **116**, the server **118**, and/or the backend API **120** may be considered to be components of the network **112**. 45

The network **112** may be any wireless network or any wired network, or a combination thereof, configured to operatively couple the above-mentioned modules, devices, and systems as shown in FIG. 1. For example, the network **112** may include one or more of the following: a PSTN (public switched telephone network), the Internet, a local intranet, a PAN (Personal Area Network), a LAN (Local Area Network), a WAN (Wide Area Network), a MAN (Metropolitan Area Network), a virtual private network (VPN), a storage area network (SAN), a frame relay connection, an Advanced Intelligent Network (MN) connection, a synchronous optical network (SONET) connection, a digital T1, T3, E1 or E3 line, a Digital Data Service (DDS) connection, a DSL (Digital Subscriber Line) connection, an Ethernet connection, an ISDN (Integrated Services Digital Network) line, a dial-up port such as a V.90, V.34, or V.34bis analog modem connection, a cable modem, an ATM (Asynchronous Transfer Mode) connection, or an FDDI (Fiber Distributed Data Interface) CDDI (Copper Distributed Data Interface) connection. Furthermore, communications may also include links to any of a variety of wireless networks, including WAP (Wireless Application Protocol), GPRS (General Packet Radio Service), GSM (Global System for Mobile Communication), CDMA (Code Division Multiple Access), TDMA (Time Division Multiple Access), FDMA (Frequency Division Multiple Access), and/or OFDMA (Orthogonal Frequency Division Multiple Access) cellular phone networks, GPS, CDPD (cellular digital packet data), RIM (Research in Motion, Limited) duplex paging network, Bluetooth radio, or an IEEE 802.11 -based radio frequency network. The network can further include or interface with any one or more of the following: RS-232 serial connection, IEEE-1394 (Firewire) connection, Fibre Channel connection, IrDA (infrared) port, SCSI (Small Computer Systems Interface) connection, USB (Universal Serial Bus) connection, or other wired or wireless, digital or analog, interface or connection, mesh or Digi® networking. 50

According to one or more aspects of the present embodiments, when a person (may be referred to interchangeably as "visitor") arrives at the A/V recording and communication doorbell **100**, the A/V recording and communication doorbell **100** detects the visitor's presence and begins capturing video images within a field of view of the camera **102**. The A/V recording and communication doorbell **100** may also 55



15

capture audio through the microphone **104**. The A/V recording and communication doorbell **100** may detect the visitor's presence using a motion sensor, and/or by detecting that the visitor has depressed the button on the A/V recording and communication doorbell **100**.

In response to the detection of the visitor, the A/V recording and communication doorbell **100** sends an alert to the user's client device **114** (FIG. 1) via the user's network **110** and the network **112**. The A/V recording and communication doorbell **100** also sends streaming video, and may also send streaming audio, to the user's client device **114**. The user answers the alert, two-way audio communication may then occur between the visitor and the user through the A/V recording and communication doorbell **100** and the users client device **114**. The user may view the visitor throughout the duration of the call, but the visitor cannot see the user (unless the A/V recording and communication doorbell **100** includes a display, which it may in some embodiments).

The video images captured by the camera **102** of the A/V recording and communication doorbell **100** (and the audio captured by the microphone **104**) may be uploaded to the cloud and recorded on the remote storage device **116** (FIG. 1) and/of the server **118**. In some embodiments, the video and/or audio may be recorded on the remote storage device **116** and/or the server **118** even if the user chooses to ignore the alert sent to his or her client device **114**.

The server **118** may comprise a computer program and/or a machine that waits for requests from other machines or software (clients) and responds to them. A server typically processes data. One purpose of a server is to share data and/or hardware and/or software resources among clients. This architecture is called the client-server model. The clients may run on the same computer or may connect to the server over a network. Examples of computing servers include database servers, file servers, mail servers, print servers, web servers, game servers, and application servers. The term server may be construed broadly to include any computerized process that shares a resource to one or more client processes. In another example, the network device to which the request is sent may be an API such as the backend API **120**, which is described below.

With further reference to FIG. 1, the system may further comprise a backend API **120** including one or more components. A backend API (application programming interface) may comprise, for example, a server (e.g. a real server, or a virtual machine, or a machine running in as cloud infrastructure as a service), or multiple servers networked together, exposing at least one API to client(s) accessing it. These servers may include components such as application servers (e.g. software servers), depending upon what other components are included, such as a caching layer, or database layers, or other components. A backend API may, for example, comprise many such applications, each of which communicate with one another using their public APIs. In some embodiments, the API backend may hold the bulk of the user data and offer the user management capabilities, leaving the clients to have very limited state.

The backend API **120** illustrated FIG. 1 may include one or more APIs. An API is a set of routines, protocols, and tools for building software and applications. An API expresses a software component in terms of its operations, inputs, outputs, and underlying types, defining functionalities that are independent of their respective implementations, which allows definitions and implementations to vary without compromising the interface. Advantageously, an API may provide a programmer with access to an applica-

16

tion's functionality without the programmer needing to modify the application itself, or even understand how the application works. An API may be for a web-based system, an operating system, or a database system, and it provides facilities to develop applications for that system using a given programming language. In addition to accessing databases or computer hardware like hard disk drives or video cards, an API can ease the work of programming GUI components. For example, an API can facilitate integration of new features into existing applications (a so-called "plug-in API"). An API can also assist otherwise distinct applications with sharing data, which can help to integrate and enhance the functionalities of the applications.

The backend API **120** illustrated in FIG. 1 may further include one or more services (also referred to as network services). A network service is an application that provides data storage, manipulation, presentation, communication, and/or other capability. Network services are often implemented using a client-server architecture based on application layer network protocols. Each service may be provided by a server component running on one or more computers (such as a dedicated server computer offering multiple services) and accessed via a network by client components running on other devices. However, the client and server components can both be run on the same machine. Clients and servers may have a user interface, and sometimes other hardware associated with them.

FIGS. 2-4 illustrate an audio/video (A/V) communication doorbell **130** according to an aspect of the present embodiments. FIG. 2 is a front view, FIG. 3 is a rear view, and FIG. 4 is a left side view of the doorbell **130** coupled with a mounting bracket **137**. The doorbell **130** includes a faceplate **135** mounted to a back plate **139** (FIG. 3). With reference to FIG. 4, the faceplate **135** has a substantially flat profile. The faceplate **135** may comprise any suitable material, including, without limitation, metals, such as brushed aluminum or stainless steel, metal alloys, or plastics. The faceplate **135** protects the internal contents of the doorbell **130** and serves as an exterior front surface of the doorbell **130**.

With reference to FIG. 2, the faceplate **135** includes a button **133** and a light pipe **136**. The button **133** and the light pipe **136** may have various profiles that may or may not match the profile of the faceplate **135**. The light pipe **136** may comprise any suitable material, including, without limitation, transparent plastic, that is capable of allowing light produced within the doorbell **130** to pass through. The light may be produced by one or more light-emitting components, such as light emitting diodes (LED's), contained within the doorbell **130**, as further described below. The button **133** may make contact with a button actuator (not shown) located within the doorbell **130** when the button **133** is pressed by a visitor. When pressed, the button **133** may trigger one or more functions of the doorbell **130**, as further described below.

With reference to FIGS. 2 and 4, the doorbell **130** further includes an enclosure **131** that engages the faceplate **135**. In the illustrated embodiment, the enclosure **131** abuts an upper edge **135T** (FIG. 2) of the faceplate **135**, but in alternative embodiments one or more gaps between the enclosure **131** and the faceplate **135** may facilitate the passage of sound and/or light through the doorbell **130**. The enclosure **131** may comprise any suitable material, but in some embodiments the material of the enclosure **131** preferably permits infrared light to pass through from inside the doorbell **130** to the environment and vice versa. The doorbell **130** further includes a lens **132**. In some embodiments, the lens may comprise a Fresnel lens, which may be patterned to deflect

17

incoming light into one or more infrared sensors located within the doorbell 130. The doorbell 130 further in a camera 134, which captures video data when activated, as described below.

FIG. 3 is a rear view of the doorbell 130, according to an aspect of the present embodiments. As illustrated, the enclosure 131 may extend from the front of the doorbell 130 around to the back thereof and may fit snugly around a lip of the back plate 139. The back plate 139 may comprise any suitable material, including, without limitation, metals, such as brushed aluminum or stainless steel, metal alloys, or plastics. The back plate 139 protects the internal contents of the doorbell 130 and serves as an exterior rear surface of the doorbell 130. The faceplate 135 may extend from the front of the doorbell 130 and at least partially wrap around the back plate 139, thereby allowing a coupled connection between the faceplate 135 and the back plate 139. The back plate 139 may have indentations in its structure to facilitate the coupling.

With further reference to FIG. 3, spring contacts 140 may provide power to the doorbell 130 when mated with other conductive contacts connected to a power source. The spring contacts 140 may comprise any suitable conductive material, including, without limitation, copper, and may be capable of deflecting when contacted by an inward force, for example the insertion of a mating element. The doorbell 130 further comprises a connector 160, such as a micro-USB or other connector, whereby power and/or data may be supplied to and from the components within the doorbell 130. A reset button 159 may be located on the back plate 139, and may make contact with a button actuator (not shown) located within the doorbell 130 when the reset button 159 is pressed. When the reset button 159 is pressed, it may trigger one or more functions, as described below.

FIG. 4 is a left side profile view of the doorbell 130 coupled to the mounting bracket 137, according to an aspect of the present embodiments. The mounting bracket 137 facilitates mounting the doorbell 130 to a surface, such as the exterior of a building, such as a home or office. As illustrated in FIG. 4, the faceplate 135 may extend from the bottom of the doorbell 130 up to just below the camera 134, and connect to the back plate 139 as described above. The lens 132 may extend and curl partially around the side of the doorbell 130. The enclosure 131 may extend and curl around the side and top of the doorbell 130, and may be coupled to the back plate 139 as described above. The camera 134 may protrude slightly through the enclosure 131, thereby giving it a wider field of view. The mounting bracket 137 may couple with the back plate 139 such that they contact each other at various points in a common plane of contact, thereby creating an assembly including the doorbell 130 and the mounting bracket 137. The couplings described in this paragraph, and elsewhere, may be secured by, for example and without limitation, screws, interference fittings, adhesives, or other fasteners. Interference fittings may refer to a type of connection where a material relies on pressure and/or gravity coupled with the material's physical strength to support a connection to a different element.

FIG. 5 is a side cross-sectional view of the doorbell 130 without the mounting bracket 137. In the illustrated embodiment, the lens 132 is substantially coplanar with the front surface 131F of the enclosure 131. In alternative embodiments, the lens 132 may be recessed within the enclosure 131 or may protrude outward from the enclosure 131. The camera 134 is coupled to a camera printed circuit board (PCB) 147, and a lens 134a of the camera 134 protrudes through an opening in the enclosure 131. The camera lens

18

134a may be a lens capable of focusing light into the camera 134 so that clear images may be taken.

The camera PCB 147 may be secured within the doorbell with any suitable fasteners, such as screws, or interference connections, adhesives, etc. The camera PCB 147 comprises various components that enable the functionality of the camera 134 of the doorbell 130, as described below. Infrared light-emitting components, such as infrared LED's 168, are coupled to the camera PCB 147 and may be triggered to activate when a light sensor detects a low level of ambient light. When activated, the infrared LED's 168 may emit infrared light through the enclosure 131 and/or the camera 134 out into the ambient environment. The camera 134, which may be configured to detect infrared light, may then capture the light emitted by the infrared LED's 168 as it reflects off objects within the camera's 134 field of view, so that the doorbell 130 can clearly capture images at night (may be referred to as "night vision").

With continued reference to FIG. 5, the doorbell 130 further comprises a front PCB 146, which in the illustrated embodiment resides in a lower portion of the doorbell 130 adjacent a battery 166. The front PCB 146 may be secured within the doorbell 130 with any suitable fasteners, such as screws, or interference connections, adhesives, etc. The front PCB 146 comprises various components that enable the functionality of the audio and light components, as further described below. The battery 166 may provide power to the doorbell 130 components while receiving power from the spring contacts 140, thereby engaging in a trickle-charge method of power consumption and supply. Alternatively, the doorbell 130 may draw power directly from the spring contacts 140 while relying on the battery 166 only when the spring contacts 140 are not providing the power necessary for all functions.

With continued reference to FIG. 5, the doorbell 130 further comprises a power PCB 148, which in the illustrated embodiment resides behind the camera PCB 147. The power PCB 148 may be secured within the doorbell 130 with any suitable fasteners, such as screws, or interference connections, adhesives, etc. The power PCB 148 comprises various components that enable the functionality of the power and device-control components, as further described below.

With continued reference to FIG. 5, the doorbell 130 further comprises a communication module 164 coupled to the power PCB 148. The communication module 164 facilitates communication with client devices in one or more remote locations, as further described below. The connector 160 may protrude outward from the power PCB 148 and extend through a hole in the back plate 139. The doorbell 130 further comprises passive infrared (PIR) sensors 144, which are secured on or within a PIR sensor holder 143, and the assembly resides behind the lens 132. The PIR sensor holder 143 may be secured to the doorbell 130 with any suitable fasteners, such as screws, or interference connections, adhesives, etc. The PIR sensors 144 may be any type of sensor capable of detecting and communicating the presence of a heat source within their field of view. Further, alternative embodiments may comprise one or more motion sensors either in place of or in addition to the PIR sensors 144. The motion sensors may be configured to detect motion using any methodology, such as a methodology that does not rely on detecting the presence of a heat source within a field of view.

FIG. 6 is an exploded view of the doorbell 130 and the mounting bracket 137 according to an aspect of the present embodiments. The mounting bracket 137 is configured to be mounted to a mounting surface (not shown) of a structure,

such as a home or an office. FIG. 6 shows the front side 137F of the mounting bracket 137. The mounting bracket 137 is configured to be mounted to the mounting surface such that the back side 137B thereof faces the mounting surface. In certain embodiments the mounting bracket 137 may be mounted to surfaces of various composition, including, without limitation, wood, concrete, stucco, brick, vinyl siding, aluminum siding, etc., with any suitable fasteners, such as screws, or interference connections, adhesives, etc. The doorbell 130 may be coupled to the mounting bracket 137 with any suitable fasteners, such as screws, or interference connections, adhesives, etc.

With continued reference to FIG. 6, the illustrated embodiment of the mounting bracket 137 includes the terminal screws 138. The terminal screws 138 are configured to receive electrical wires adjacent the mounting surface of the structure upon which the mounting bracket 137 is mounted, so that the doorbell 130 may receive electrical power from the structure's electrical system. The terminal screws 138 are electrically connected to electrical contacts 177 of the mounting bracket. If power is supplied to the terminal screws 138, then the electrical contacts 177 also receive power through the terminal screws 138. The electrical contacts 177 may comprise any suitable conductive material, including, without limitation, copper, and may protrude slightly from the face of the mounting bracket 137 so that they may mate with the spring contacts 140 located on the back plate 139.

With reference to FIGS. 6 and 7 (which is a rear view of the mounting bracket 137), the mounting bracket 137 further comprises a bracket PCB 149. With reference to FIG. 7, the bracket PCB 149 is situated outside the doorbell 130, and is therefore configured for various sensors that measure ambient conditions, such as an accelerometer 150, a barometer 151, a humidity sensor 152, and a temperature sensor 153. The functions of these components are discussed in more detail below. The bracket PCB 149 may be secured to the mounting bracket 137 with any suitable fasteners, such as screws, or interference connections, adhesives, etc.

FIGS. 8A and 8B are top and bottom views, respectively, of the doorbell 130. As described above, the enclosure 131 may extend from the front face 131F of the doorbell 130 to the back, where it contacts and snugly surrounds the back plate 139. The camera 134 may protrude slightly beyond the front face 131F of the enclosure 131, thereby giving the camera 134 a wider field of view. The mounting bracket 137 may include a substantially flat rear surface 137R, such that the doorbell 130 and the mounting bracket 137 assembly may sit flush against the surface to which they are mounted. With reference to FIG. 8B, the lower end of the enclosure 131 may include security screw apertures 141 configured to receive screws or other fasteners.

FIG. 9A is a top view of the PIR sensor holder 143. The PIR sensor holder 143 may comprise any suitable material, including, without limitation, metals, metal alloys or plastics. The PIR sensor holder 143 is configured to mount the PIR sensors 144 behind the lens 132 such that the PIR sensors 144 face out through die lens 132 at varying angles, thereby creating a wide field of view for the PIR sensors 144, and dividing the field of view into zones, as further described below. With further reference to FIG. 9A, the PIR sensor holder 143 includes one or more faces 178 within or on which the PIR sensors 144 may be mounted. In the illustrated embodiment, the PIR sensor holder 143 includes three faces 178, with each of two outer faces 178 angled at 55° with respect to a center one of the faces 178. In alternative embodiments, the angle formed by adjacent ones

of the faces 178 may be increased or decreased as desired to alter the field of view of the PIR sensors 144.

FIG. 9B is a front view of the PIR sensor holder 143. In the illustrated embodiment, each of the faces 178 includes a through hole 180 in which the PIR sensors 144 may be mounted. First and second brackets 182, spaced from one another, extend transversely across the PIR sensor holder 143. Each of the brackets 182 includes notches 184 at either end. The brackets 182 may be used to secure the PIR sensor holder 143 within the doorbell 130. In alternative embodiments, the through holes 180 in the faces 178 may be omitted. For example, the PIR sensors 144 may be mounted directly to the faces 178 without the through holes 180. Generally, the faces 178 may be comprise any structure configured to locate and secure the PIR sensors 144 in place.

FIGS. 10A and 10B are top and front views, respectively, of a PIR sensor assembly 179, including the PIR sensor holder 143, the lens 132, and a flexible power circuit 145. The PIR sensor holder 143 may be secured to a rear face 132R of the lens 132, as shown, with the brackets 182 abutting the rear face 132R of the lens 132. The flexible power circuit 145, which may be any material or component capable of delivering power and/or data to and from the PIR sensors 144, is secured to a rear face 143R of the PIR sensor holder 143, and may be contoured to match the angular shape of the PIR sensor holder 143. The flexible power circuit 145 may connect to, draw power from, and/or transmit data to and/or from, the power PCB 148 (FIG. 5).

FIG. 11 is a top view of the PIR sensor assembly 179 illustrating the fields of view of the PIR sensors 144. Each PIR sensor 144 in a field of view, referred to as a "zone," that traces an angle extending outward from the respective PIR sensor 144. Zone 1 is the area that is visible only to Passive Infrared Sensor 144-1. Zone 2 is the area that is visible only to the PIR sensors 144-1 and 144-2. Zone 3 is the area that is visible only to Passive Infrared Sensor 144-2. Zone 4 is the area that is visible only to the PIR sensors 144-2 and 144-3. Zone 5 is the area that is visible only to Passive Infrared Sensor 144-3. The doorbell 130 may be capable of determining the direction that an object is moving based upon which zones are triggered in a time sequence. In the illustrated embodiment, each zone extends across an angle of 110°. In alternative embodiments, each zone may extend across a different angle, such as one greater than or less than 110°.

FIG. 12 is a functional block diagram of the components within or in communication with the doorbell 130, according to an aspect of the present embodiments. As described above, the bracket PCB 149 may comprise an accelerometer 150, a barometer 151, a humidity sensor 152, and a temperature sensor 153. The accelerometer 150 may be one or more sensors capable of sensing motion and/or acceleration. The barometer 151 may be one or more sensors capable of determining the atmospheric pressure of the surrounding environment in which the bracket PCB 149 may be located. The humidity sensor 152 may be one or more sensors capable of determining the amount of moisture present in the atmospheric environment in which the bracket PCB 149 may be located. The temperature sensor 153 may be one or more sensors capable of determining the temperature of the ambient environment in which the bracket PCB 149 may be located. As described above, the bracket PCB 149 may be located outside the housing of the doorbell 130 so as to reduce interference from heat, pressure, moisture, and/or other stimuli generated by the internal components of the doorbell 130.

21

With further reference to FIG. 12, the bracket PCB 149 may further comprise terminal screw inserts 154, which may be configured to receive the terminal screws 138 and transmit power to the electrical contacts 177 on the mounting bracket 137 (FIG. 6). The bracket PCB 149 may be electrically and/or mechanically coupled to the power PCB 148 through the terminal screws 138, the terminal screw inserts 154, the spring contacts 140, and the electrical contacts 177. The terminal screws 138 may receive electrical wires located at the surface to which the doorbell 130 is mounted, such as the wall of a building, so that the doorbell can receive electrical power from the building's electrical system. Upon the terminal screws 138 being secured within the terminal screw inserts 154, power may be transferred to the bracket PCB 149, and to all of the components associated therewith, including the electrical contacts 177. The electrical contacts 177 may transfer electrical power to the power PCB 148 by mating with the spring contacts 140.

With further reference to FIG. 12, the front PCB 146 may comprise a light sensor 155, one or more light-emitting components, such as LED's 156, one or more speakers 157, and a microphone 158. The light sensor 155 may be one or more sensors capable of detecting the level of ambient light of the surrounding environment in which the doorbell 130 may be located. LED's 156 may be one or more light-emitting diodes capable of producing visible light when supplied with power. The speakers 157 may be any electro-mechanical device capable of producing sound in response to an electrical signal input. The microphone 158 may be an acoustic-to-electric transducer or sensor capable of converting sound waves into an electrical signal. When activated, the LED's 156 may illuminate the light pipe 136 (FIG. 2). The front PCB 146 and all components thereof may be electrically coupled to the power PCB 148, thereby allowing data and/or power to be transferred to and from the power PCB 148 and the front PCB 146.

The speakers 157 and the microphone 158 may be coupled to the camera processor 170 through an audio CODEC 161. For example, the transfer of digital audio from the user's client device 114 and the speakers 157 and the microphone 158 may be compressed and decompressed using the audio CODEC 161, coupled to the camera processor 170. Once compressed by audio CODEC 161, digital audio data may be sent through the communication module 164 to the network 112, routed by one or more servers (not shown), and delivered to the user's client device 114. When the user speaks, after being transferred through the network 112, digital audio data is decompressed by audio CODEC 161 and emitted to the visitor via the speakers 157.

With further reference to FIG. 12, the power PCB 148 may comprise a power management module 162, a microcontroller 163, the communication module 164, and power PCB non-volatile memory 165. In certain embodiments, the power management module 162 may comprise an integrated circuit capable of arbitrating between multiple voltage rails, thereby selecting the source of power for the doorbell 130. The battery 166, the spring contacts 140, and/or the connector 160 may each provide power to the power management module 162. The power management module 162 may have separate power rails dedicated to the battery 166, the spring contacts 140, and the connector 160. In one aspect of the present disclosure, the power management module 162 may continuously draw power from the battery 166 to power the doorbell 130, while at the same time routing power from the spring contacts 140 and/or the connector 160 to the battery 166, thereby allowing the battery 166 to maintain a substantially constant level of charge. Alternatively, the

22

power management module 162 may continuously draw power from the spring contacts 140 and/or the connector 160 to power the doorbell 130, while only drawing from the battery 166 when the power from the spring contacts 140 and/or the connector 160 is low or insufficient. The power management module 162 may also serve as a conduit for data between the connector 160 and the microcontroller 163.

With further reference to FIG. 12, in certain embodiments the microcontroller 163 may comprise an integrated circuit including a processor core, memory, and programmable input/output peripherals. The microcontroller 163 may receive input signals, such as data and/or power, from the PIR sensors 144, the bracket PCB 149, the power management module 162, the light sensor 155, the microphone 158, and/or the communication module 164, and may perform various functions as further described below. When the microcontroller 163 is triggered by the PIR sensors 144, the microcontroller 163 may be triggered to perform one or more functions, such as those described below with reference to FIG. 14. When the light sensor 155 detects a low level of ambient light, the light sensor 155 may trigger the microcontroller 163 to enable "night vision," as further described below. The microcontroller 163 may also act as a conduit for data communicated between various components and the communication module 164.

With further reference to FIG. 12, the communication module 164 may comprise an integrated circuit including a processor core, memory, and programmable input/output peripherals. The communication module 164 may also be configured to transmit data wirelessly (and/or over a wired connection) to a remote network device, and may include one or more transceivers (not shown). The wireless communication may comprise one or more wireless networks, such as, without limitation, Wi-Fi, cellular, Bluetooth, and/or satellite networks. The communication module 164 may receive inputs, such as power and/or data, from the camera PCB 147, the microcontroller 163, the button 133, the reset button 159, and/or the power PCB non-volatile memory 165. When the button 133 is pressed, the communication module 164 may be triggered to perform one or more functions, such as those described below with reference to FIG. 13. When the reset button 159 is pressed, the communication module 164 may be triggered to erase any data stored at the power PCB non-volatile memory 165 and/or at the camera PCB memory 169. The communication module 164 may also act as a conduit for data communicated between various components and the microcontroller 163. The power PCB non-volatile memory 165 may comprise flash memory configured to store and/or transmit data. For example, in certain embodiments the power PCB non-volatile memory 165 may comprise serial peripheral interface (SPI) flash memory.

With further reference to FIG. 12, the camera PCB 147 may comprise components that facilitate the operation of the camera 134. For example, an imager 171 may comprise a video recording sensor and/or a camera chip. In one aspect of the present disclosure, the imager 171 may comprise a complementary metal-oxide semiconductor (CMOS) array, and may be capable of recording high definition (720p or better) video files. A camera processor 170 may comprise an encoding and compression chip. In some embodiments, the camera processor 170 may comprise a bridge processor. The camera processor 170 may process video recorded by the imager 171 and audio recorded by the microphone 158, and may transform this data into a form suitable for wireless transfer by the communication module 164 to a network. The camera PCB memory 169 may comprise volatile memory that may be used when data is being buffered or

encoded by the camera processor 170. For example, in certain embodiments the camera PCB memory 169 may comprise synchronous dynamic random access memory (SD RAM). IR LED's 168 may comprise light-emitting diodes capable of radiating infrared light. IR cut filter 167 may comprise a system that, when triggered, configures the imager 171 to see primarily infrared light as opposed to visible light. When the light sensor 155 detects a low level of ambient light (which may comprise a level that impedes the performance of the imager 171 in the visible spectrum), the IR LED's 168 may shine infrared light through the doorbell 130 enclosure out to the environment, and the IR cut filter 167 may enable the imager 171 to see this infrared light as it is reflected or refracted off of objects within the field of view of the doorbell. This process may provide the doorbell 130 with the "night vision" function mentioned above.

FIG. 13 is a flowchart illustrating one embodiment of a process according to an aspect of the present disclosure. At block B200, a visitor presses the button 133 on the doorbell 130. At block B202, the communication module 164 sends a request to a network device. Once the network device receives the request, at block B204 the network device may connect the doorbell 130 to the user's client device 114 through the user's network 110 and the network 112. In block B206, the doorbell 130 may record available audio and/or video data using the camera 134, the microphone 158, and/or any other sensor available. At block B208, the audio and/or video data is transmitted to the user's client device 114. At block B210, the user may receive a notification on his or her client device 114 prompting him or her to either accept or deny. If the user denies the notification, then the process advances to block B214 where the audio and/or video data is recorded and stored at a cloud server. The session then ends at block B216 and the connection between the doorbell 130 and the user's client device 114 is terminated. If, however, the user elects to accept the notification, then at block B212 the user communicates with the visitor through the user's client device 114 while being provided audio and/or video data captured by the camera 134, the microphone 158, and/or other sensors. At the end of the call, the user may terminate the connection between the user's client device 114 and the doorbell 130 and the session ends at block B216. In some embodiments, the audio and/or video data may be recorded and stored at a cloud server even if the user accepts the notification and communicates with the visitor through the user's client device 114.

FIG. 14 is a flowchart illustrating another embodiment of a process according to an aspect of the present disclosure. At block B300, an object may move into the field of view of one or more of the PIR sensors 144. At block B302, the PIR sensors 144 may trigger the microcontroller 163, which may then trigger the communication module 164 to send a request to a network device. At block B304, the network device may connect the doorbell 130 to the user's client device 114 through the user's network 110 and the network 112. At block B306, the doorbell 130 may record available audio and/or video data using the camera 134, the microphone 158, and/or any other available sensor, and stream the data to the user's client device 114. At block B308, the user may receive a notification prompting the user to either accept or deny the notification. If the notification is accepted, then at block B310a the live audio/video data may be displayed on the user's client device 114, thereby allowing the user surveillance from the perspective of the doorbell 130. When the user is satisfied with this function, the user may sever the connection at block B312, whereby the

session ends. If, however, at block B308 the user denies the notification, or ignores the notification and a specified time interval elapses, then the connection between the doorbell 130 and the user's client device 114 is terminated and the audio/video data is recorded and stored at a cloud server at block B310b, such that the user may view the audio/video data later at their convenience. The doorbell 130 may be configured to record for a specified period of time in the event the notification in block B308 is denied or ignored. If such a time period is set, the doorbell 130 may record data for that period of time before ceasing operation at block B312 thereby ending the session.

FIG. 15 is a flowchart illustrating another embodiment of a process according to an aspect of the present disclosure. At block B400, the user may select a "snooze time-out," which is a time period during which the doorbell 130 may deactivate or otherwise not respond to stimuli (such as light, sound, or heat signatures) after an operation is performed, e.g. a notification is either accepted or denied/ignored. For example, the user may set a snooze time-out of 15 minutes. At block B402, an object moves into the field of view of one or more of the PIR sensors 144. At block B404, the microcontroller 163 may trigger the communication module 164 to send a request to a network device. In block B406, the network device may connect the doorbell 130 to the user's client device 114 through the user's network 110 and the network 112. At block B408, audio/video data captured by the doorbell 130 may be streamed to the user's client device 114. At block B410, the user may receive a notification prompting the user to either accept or deny ignore the request. If the request is denied or ignored, then at block B412b audio/video data may be recorded and stored at a cloud server. After the doorbell 130 finishes recording, the objects may remain in the PIR sensor 144 field of view at block B414. In block B416, the microcontroller 163 waits for the "snooze time" to elapse, e.g. 15 minutes, before triggering the communication module 164 to submit another request to the network device. After the snooze time, e.g. 15 minutes, elapses, the process moves back to block B404 and progresses as described above. The cycle may continue like this until the user accepts the notification request at block B410. The process then moves to block B412a, where live audio and/or video data is displayed on the user's client device 114, thereby allowing the user surveillance from the perspective of the doorbell 130. At the user's request, the connection may be severed and the session ends at block B418. At this point the user may elect for the process to revert back to block B416, whereby there may be no further response until the snooze time, e.g. 15 minutes, has elapsed from the end of the previous session, or the user may elect for the process to return to block B402 and receive a notification the next time an object is perceived by one or more of the PIR sensors 144.

#### Continual Information Sampling at Regular Intervals

As described above, the present embodiments leverage the capabilities of audio/video (A/V) recording and communication devices, thereby providing enhanced functionality to such devices to reduce crime and increase public safety. One aspect of the present embodiments includes the realization that some methods for detecting motion with an A/V recording and communication device include undesirable latency. For example, in some methods a processor may not sample or analyze any information from motion sensors until it receives an interrupt. The processor then must gather at least a threshold number of information samples, which requires waiting at least a threshold number of sampling intervals, in order to gather enough information to confirm

25

(or disconfirm) that motion is indicated. The time spent sampling information from the motion sensors after the interrupt thus creates latency. As further described below, processes according to the present embodiments solve this latency problem by enabling the processor to continually sample information from the motion sensors at regular intervals. Thus, in some embodiments, as soon as the sampled information indicates motion, the processor may immediately signal other components of the A/V recording and communication device to power up, thus eliminating the latency problem described above.

FIGS. 16 and 17 are graphs illustrating two processes for detecting motion with an A/V recording and communication device, according to the present embodiments. With reference to FIG. 16, the curve 500 represents the output signal from the PIR sensors 144. The curve 500 is plotted on horizontal and vertical axes representing time and intensity (or magnitude), respectively. For simplicity and clarity, only one curve 500 is illustrated in FIG. 16, even though each of the three PIR sensors 144 may produce a separate output signal.

As long as the PIR sensors 144 are powered on, they continually gather information from the field of view of the doorbell 130. For the PIR sensors 144, gathering information may comprise receiving IR radiation from one or more objects in the field of view of the doorbell 130. However, in some embodiments the doorbell 130 is configured to conserve power during periods of little or no activity in the vicinity of the doorbell 130. Thus, many, if not most or substantially all, of the components of the doorbell 130 may be in a low-power state (may also be referred to as a sleep state or a hibernation state) during periods of little or no activity in the field of view of the doorbell 130. For example, the microcontroller 143 (FIG. 12) may be in a low-power state until “woken up” by the PIR sensors 144. When the PIR sensors 144 detect motion (or possible motion) in the field of view of the doorbell 130, the PIR sensors 144 generate an interrupt 502 for the microcontroller 163, represented by the vertical dashed line in FIG. 16. In response to the interrupt 502, the microcontroller 163 powers up to an active state and commences sampling information from the PIR sensors 144 at regularly spaced sampling intervals 504, as represented by the vertical solid lines under the curve in FIG. 16. The sampling intervals 504 may have any time spacing, but in one example embodiment the microcontroller 143 may sample the information from the PIR sensors 144 at 64 Hz (one sample every 15.625 ms).

The microcontroller 163 analyzes the information in each sample, and continues sampling and analyzing the information from the PIR sensors 144 until enough information has been sampled and analyzed for the microcontroller 163 to determine whether there is actually motion in the field of view of the doorbell 130. In some embodiments, a number of sampling intervals 504 may be a preset number, or may be whatever number of samples is needed to make a positive determination that there is motion within the field of view of the doorbell 130. If the sampled information indicates motion, then the microcontroller 163 generates a signal to power up other components of the doorbell 130. For example, at least one of the communication module 164 (FIG. 12), the camera processor 170, and the imager 171 may power up in response to the signal from the microcontroller 163. The doorbell 130 may then begin streaming video and/or audio content to the user’s client device 114, in accordance with the streaming process described above. If, however, the sampled information does not indicate motion,

26

then the processor may revert to the low-power state until it receives another interrupt 502 from the PIR sensors 144.

In the process described above with reference to FIG. 16, the microcontroller 163 does not sample or analyze any information from the PIR sensors 144 until it receives the interrupt 502, as indicated by the blank area 506 under the curve 500 to the left of the dashed vertical line 502. The process of FIG. 16 thus includes undesirable latency. The process illustrated in FIGS. 17 and 18 solves this latency problem by enabling the microcontroller 163 to continually sample information from the PIR sensors 144 at regular intervals.

With reference to FIG. 17, the microcontroller 163 continually samples information from the PIR sensors 144 at regular sampling intervals 510, as represented by the vertical solid lines under the curve 512 in FIG. 17. Between sampling intervals 510, the microcontroller 163 is in the low-power state, as represented by the spaces between the vertical solid lines 510 under the curve 512 in FIG. 17. At each sampling interval 510, the microcontroller 163 powers up to the active state, analyzes the information in the sample, and then immediately reverts to the low-power state until the next sampling interval 510, unless a threshold number of consecutive samples and respective magnitudes indicate that motion is happening in the field of view of the doorbell 130. If a threshold number of consecutive samples and respective magnitudes indicate that motion is happening in the field of view of the doorbell 130, then the microcontroller 163 generates a signal to power up other components of the doorbell 130, such as at least one of the communication module 164 (FIG. 12), the camera processor 170, and the imager 171. In some embodiments, the threshold number of consecutive samples may be a preset number, or may be whatever number of samples is needed to make a positive determination that there motion within the field of view of the doorbell 130.

FIG. 18 illustrates the foregoing process in further detail. At block B520, the PIR sensors 144 gather information from the area in the field of view of the doorbell 130 and generate an output signal 512 (FIG. 17). Then, at block B522 at a sampling interval 510 (FIG. 17), the microcontroller 163 powers up to the active state, and samples and analyzes the information from the PIR sensors 144. The process then moves to block B524, where the microcontroller 163 determines whether the sampled information indicates motion in the field of view of the doorbell 130. If not, then the process moves to block B526, where the microcontroller 163 reverts to the low-power state and waits until the next sampling interval, at which time the process reverts to block B522 and repeats blocks B522 and B524. If, however, the microcontroller 163 determines at block B524 that the sampled information indicates motion in the field of view of the doorbell 130, then the process moves to block B528, where the microcontroller 163 generates a signal to power up other components of the doorbell 130. While not shown in FIG. 18, after block B528 the doorbell 130 streams audio and/or video content to the user’s client device 114.

In certain embodiments, the determination at block B524 (whether the sampled information indicates motion in the field of view of the doorbell 130) is based on sampling and analysis of a threshold number of samples, where the threshold number is an integer greater than 1. Thus, the process of FIG. 18 may loop through blocks B522-B526 until the threshold number of samples is reached, after which the process moves to block B528, unless no motion is indicated by the threshold number of samples, in which case the process will continue to loop through blocks B522-

B526. The threshold number of samples is discussed in further detail below with reference to FIG. 28.

The process of FIGS. 17 and 18 advantageously decreases latency compared to the process of FIG. 16. In the process of FIG. 16, the microcontroller 163 doesn't begin to sample information from the PIR sensors 144 until it receives an interrupt. The microcontroller 163 then must gather at least a threshold number of information samples, which requires waiting at least a threshold number of sampling intervals, in order to gather enough information to confirm (or disconfirm) that motion is indicated in the field of view of the doorbell 130. The time spent sampling information from the PIR sensors 144 thus creates latency. By contrast, in the process of FIGS. 17 and 18 the microcontroller 163 is continually sampling information from the PIR sensors 144 at regular intervals. Thus, as soon as the sampled information indicates motion, the microcontroller 163 immediately signals the other components of the doorbell 130 to power up, thus eliminating the latency of the process of FIG. 16.

The process of FIGS. 17 and 18 does not create a severe power drain on the battery 166, at least in part because the microcontroller 163 is in the low-power state between sampling intervals. Further, the process of FIGS. 17 and 18 may be executed with a microcontroller 163 having a relatively slow processor clock, for example 4 MHz. The relatively slow processor clock enables the microcontroller 163 to consume relatively little power, so that the battery 166 does not drain too quickly.

#### Filters

Another aspect of the present embodiments includes the realization that a motion sensor will generally detect a vehicle passing through its field of view, but a user will generally not want to be bothered by alerts generated in response to vehicles. As further described below, processes according to the present embodiments solve this problem by filtering out motion of vehicles in order to reduce false positive signals. Another aspect of the present embodiments includes the realization that false positive signals are sometimes generated by direct sunlight impinging on motion sensors, such as PIR sensors, and/or by rapid temperature changes within the A/V recording and communication device. As further described below, processes according to the present embodiments solve this problem by filtering out these stimuli in order to reduce false positive signals.

#### Vehicle Filter

FIGS. 19 and 20 illustrate a process for filtering out motion of vehicles, according to the present embodiments. With reference to FIG. 19, three curves 540, 542, 544 represent the output signals from the three PIR sensors 144, respectively labeled PIR<sub>1</sub>, PIR<sub>2</sub>, and PIR<sub>3</sub>. With reference to FIG. 11, as an object moves across the field of view of the doorbell 130 (from left to right or right to left), it passes through, consecutively, the fields of view of the individual PIR sensors 144-1, 144-2, 144-3. Thus, the discrete output signals PIR<sub>1</sub>, PIR<sub>2</sub>, PIR<sub>3</sub> generated by each of the PIR sensors 144-1, 144-2, 144-3 are spaced from one another along the x-axis in FIG. 19. If the object is moving quickly across the field of view of the doorbell 130, the output signals PIR<sub>1</sub>, PIR<sub>2</sub>, PIR<sub>3</sub> will be closely spaced along the x-axis. Conversely, if the object is moving slowly across the field of view of the doorbell 130, the output signals PIR<sub>1</sub>, PIR<sub>2</sub>, PIR<sub>3</sub> will be spaced far apart along the x-axis. Since vehicles generally move faster than people, vehicles can be filtered out by comparing the spacing of the output signals PIR<sub>1</sub>, PIR<sub>2</sub>, PIR<sub>3</sub> with a threshold value and, if the spacing is less than the threshold value, it can be assumed that the motion indicates a vehicle.

One advantageous way to measure the spacing between the output signals PIR<sub>1</sub>, PIR<sub>2</sub>, PIR<sub>3</sub> is to calculate local maxima and minima for each of the curves 540, 542, 544, and to calculate the spacing between the local maxima and minima. For example, with continued reference to FIG. 19, the first output signal PIR<sub>1</sub> includes a local maximum  $\max_{PIR_1}$  and a local minimum  $\min_{PIR_1}$ . Likewise, the second output signal PIR<sub>2</sub> includes a local maximum  $\max_{PIR_2}$  and a local minimum  $\min_{PIR_2}$ , and the third output signal PIR<sub>3</sub> includes a local maximum  $\max_{PIR_3}$  and a local minimum  $\min_{PIR_3}$ . After calculating the locations of each of  $\max_{PIR_1}$ ,  $\max_{PIR_2}$ ,  $\max_{PIR_3}$ ,  $\min_{PIR_1}$ ,  $\min_{PIR_2}$ , and  $\min_{PIR_3}$ , the spacing between each pair of local maxima and each pair of local minima is calculated by subtracting the time coordinates of each pair ( $\max_{PIR_2} - \max_{PIR_1}$ ,  $\max_{PIR_3} - \max_{PIR_2}$ ,  $\max_{PIR_3} - \max_{PIR_1}$ ;  $\min_{PIR_2} - \min_{PIR_1}$ ,  $\min_{PIR_3} - \min_{PIR_2}$ ,  $\min_{PIR_3} - \min_{PIR_1}$ ). The result of each subtraction operation is then compared with a threshold value. If any of the results of the subtraction operations is less than the threshold value, it is likely that the motion indicates a vehicle, because faster moving objects cause the PIR sensors 144 to generate output signals that are closer to one another in time. Output signals from the PIR sensors 144 that are likely to have been caused by a vehicle can be filtered out (ignored) for purposes of determining when to send an alert signal to the user's client device 114. The present process thus advantageously results in fewer alert signals by filtering out those motions that are generated by vehicles, because the user is not likely to be interested in being notified about these types of motions.

FIG. 20 illustrates the foregoing process in further detail. At block B550, a first one of the PIR sensors 144 detects a moving object within its field of view and generates a first output signal. The first one of the PIR sensors 144 to generate the first output signal may be any of the PIR sensors 144-1, 144-2, 144-3, depending upon the location and/or direction of movement of the object. Then, at block B552, a second one of the PIR sensors 144 detects the moving object within its field of view and generates a second output signal. Again, the second one of the PIR sensors 144 to generate the second output signal may be any of the PIR sensors 144-1, 144-2, 144-3, depending upon the location and/or direction of movement of the object.

At block B554, the time coordinates for a local maximum and a local minimum of the first output signal are calculated, and at block B556 the time coordinates for a local maximum and a local minimum of the second output signal are calculated. At block B558, the spacing between the local maximum of the first output signal and the local maximum of the second output signal is calculated, and the spacing between the local minimum of the first output signal and the local minimum of the second output signal is calculated. At block B560, the spacings calculated at block B558 are compared with a threshold value. If any of the spacings is less than the threshold value, then at block B562 it is determined that the moving object is likely to be a motor vehicle. If, however, none of the spacings is less than the threshold value, then at block B564 it is determined that the moving object is likely not to be a motor vehicle. At any of blocks B554-B564, the microcontroller 163 may perform any or all of the steps of calculating, comparing, and/or determining.

The foregoing process advantageously filters out signals from the PIR sensors 144 that are likely to have been caused by a vehicle. This process thus advantageously results in fewer alert signals being sent to the user, thereby reducing the frequency of false positive alerts.

In another embodiment of a process for filtering out motion of vehicles, the magnitude of the output signal from one or more of the PIR sensors 144 may be compared to a threshold value to determine if the output signal is likely to be indicative of a motor vehicle. As described above, motor vehicles generally move more quickly than pedestrians, and faster moving objects generally produce output signals of greater magnitude from motion sensors, as compared to slower moving objects. Thus, if the magnitude of a given output signal from one or more of the PIR sensors 144 is greater than the threshold value, it can be determined that the moving object is likely to be a motor vehicle. Such output signals can be filtered out to reduce the number of false positive alerts to the user's client device 114.

In certain embodiments, the magnitude of the output signal from one or more of the PIR sensors 144 may be used as a check on the process of FIG. 20, and vice versa. For example, if it is determined that any of the spacings between local maxima and minima is less than a threshold value, which is indicative of vehicle motion, then it may also be determined whether the magnitude of the output signal from the PIR sensors 144 is greater than a threshold value, which it should be if the PIR sensors 144 are in fact detecting vehicle motion. Conversely, if it is determined that the magnitude of the output signal from the PIR sensors 144 is greater than a threshold value, which is indicative of vehicle motion, then it may also be determined whether any of the spacings between local maxima and minima is less than a threshold value, which it should be if the PIR sensors 144 are in fact detecting vehicle motion. If, in either case, the determinations (spacings vs. magnitude of output signal) contradict one another, the process may loop back and repeat one or more steps before making a final determination whether the PIR sensors 144 are detecting vehicle motion.

#### Sunlight Filter

FIGS. 21 and 22 illustrate a process for reducing false positive signals that might be generated by direct sunlight impinging on the PIR sensors 144, according to the present embodiments. Direct sunlight impinging on the PIR sensors 144 can generate a false positive detection of movement, because the PIR sensors 144 are sensitive to heat signatures of objects, and the radiative heat of direct sunlight can be falsely interpreted by the PIR sensors 144 to be an object within the field of view of the PIR sensors 144. This effect of sunlight on the PIR sensors 144 can be especially problematic when the sunlight falling on the PIR sensors 144 is intermittent, as can happen when the PIR sensors 144 are in the shade of a tree or another type of object that tends to sway in the wind. The present embodiments are configured to filter out these types of false positives.

With reference to FIG. 21, one embodiment of a sunlight filter uses the rate of change of the output signal from the PIR sensors 144 to determine whether it is likely that the output signal is result of direct sunlight impinging on the PIR sensors 144. Direct sunlight falling on the PIR sensors 144 tends to produce output signals that change rapidly, especially when the sunlight falling on the PIR sensors 144 is intermittent, because of the rapid changes in temperature that can occur when the PIR sensors 144 are alternately receiving direct sun and shade. Thus, the present embodiment calculates the rate of change (represented by " $\Delta$ " in FIG. 21) of the output signal 570 from the PIR sensors 144 by calculating the difference in the magnitude of the output signal 570 at a first sampling interval 572 and at a second sampling interval 574. The calculated rate of change is then compared to a threshold value, and if the rate of change is

greater than the threshold value, it is determined that the signal is likely caused by intermittent direct sunlight.

In FIG. 21, the first and second sampling intervals 572, 574 are illustrated as being consecutive, but in certain embodiments they may not be consecutive. Further, for simplicity and clarity, only one output signal 570 is shown in FIG. 21, even though each of the three PIR sensors 144 may produce a separate output signal.

FIG. 22 illustrates the foregoing process in further detail. At block B580, the PIR sensors 144 gather information from the area in the field of view of the doorbell 130 and generate an output signal 570 (FIG. 21). Then, at block B582, at a first sampling interval 572 (FIG. 21), the microcontroller 163 samples and analyzes the information from the PIR sensors 144 and calculates the magnitude of the output signal 570 during the first sampling interval 572. Then, at block B584, at a second sampling interval 574 (FIG. 21), the microcontroller 163 samples and analyzes the information from the PIR sensors 144 and calculates the magnitude of the output signal 570 during the second sampling interval 574. At block B586, microcontroller 163 calculates the difference between the magnitudes of the output signal 570 during the first and second sampling intervals 572, 574. At block B588, the difference calculated at block B586 is compared with a threshold value. If the difference is greater than the threshold value, then at block B590 it is determined that the PIR sensors 144 are likely exposed to intermittent direct sunlight. If, however, the difference is not greater than the threshold value, then at block B592 it is determined that the PIR sensors 144 are likely not exposed to intermittent direct sunlight.

The foregoing process advantageously filters out signals from the PIR sensors 144 that are likely to have been caused by intermittent direct sunlight. This process thus advantageously results in fewer alert signals being sent to the user, thereby reducing the frequency of false positive alerts.

With reference to FIG. 23, another embodiment of a sunlight filter uses the peak magnitude 600 of the output signal 602 from the PIR sensors 144 to determine whether it is likely that the output signal 602 is the result of direct sunlight falling on the PIR sensors 144. Direct sunlight falling on the PIR sensors 144 tends to produce output signals having large magnitudes, especially when the sunlight falling on the PIR sensors 144 is intermittent, because of the rapid changes in temperature that can occur when the PIR sensors 144 are alternately receiving direct sun and shade. Thus, in the present embodiment the microcontroller 163 samples the output signal 602 over multiple sampling intervals 604 and calculates the peak magnitude 600 of the output signal 602 during those sampling intervals 604. The calculated peak magnitude 600 is then compared to a threshold value, and if the peak magnitude 600 is greater than the threshold value, it is determined that the signal is likely caused by intermittent direct sunlight. In FIG. 23, for simplicity and clarity, only one output signal 602 is shown, even though each of the three PIR sensors 144 may produce a separate output signal.

FIG. 24 illustrates the foregoing process in further detail. At block B610, the PIR sensors 144 gather information from the area in the field of view of the doorbell 130 and generate an output signal 602 (FIG. 23). Then, at block B612, the microcontroller 163 samples the output signal 602 over multiple sampling intervals 604 and analyzes the information in the output signal 602 at each sampling interval 604. Then, at block B614, the microcontroller 163 determines the peak magnitude 600 of the output signal 602 over the multiple sampling intervals 604. At block B616, the peak



magnitude **600** of the output signal **602** is compared with a threshold value. If the peak magnitude **600** is greater than the threshold value, then at block **B618** it is determined that the PIR sensors **144** are likely exposed to intermittent direct sunlight. If, however, the peak magnitude **600** is not greater than the threshold value, then at block **B620** it is determined that the PIR sensors **144** are likely not exposed to intermittent direct sunlight.

The foregoing process advantageously filters out signals from the PIR sensors **144** that are likely to have been caused by intermittent direct sunlight. This process thus advantageously results in fewer alert signals being sent to the user, thereby reducing the frequency of false positive alerts.

In certain embodiments, the processes of FIGS. **22** and **24** may be combined in order to increase the accuracy of the determination of whether the PIR sensors **144** are exposed to intermittent direct sunlight. For example, if it is determined that the rate of change of the output signal from the PIR sensors **144** is greater than a threshold value, which is indicative of the PIR sensors **144** being exposed to intermittent direct sunlight, then it may also be determined whether the magnitude of the output signal from the PIR sensors **144** is also greater than a threshold value, which it should be if the PIR sensors **144** are in that exposed to intermittent direct sunlight. Conversely, if it is determined that the magnitude of the output signal from the PIR sensors **144** is greater than a threshold value, which is indicative of the PIR sensors **144** being exposed to intermittent direct sunlight, then it may also be determined whether the rate of change of the output signal from the PIR sensors **144** is also greater than a threshold value, which it should be if the PIR sensors **144** are in fact exposed to intermittent direct sunlight. If, in either case, the determinations (rate of change of output signal vs. magnitude of output signal) contradict one another, the process may loop back and repeat one or more steps before making a final determination whether the PIR sensors **144** are exposed to intermittent direct sunlight.

#### Temperature Filter

FIG. **25** illustrates a process for reducing false positive signals that might be generated by rapid temperature changes within the doorbell **130**, according to the present embodiments. In cold climates, the temperature within the doorbell **130** may change rapidly when one or more components of the doorbell **130** transition from a low-power state to an active state, and/or when one or more components of the doorbell **130** transition from a powered-off state to a powered-on state. This effect results from the fact that many of the components of the doorbell **130** generate their own heat when they are in an active state or a powered-on state. The heat generated by these components can cause a rapid temperature change within the doorbell **130** when the doorbell **130** is located in a region where the ambient temperature is cold. Such a rapid temperature change can cause the PIR sensors **144** to become unstable, which can result in unpredictable signal outputs from the PIR sensors **144**. The process of FIG. **25** filters out the signal outputs from the PIR sensors **144** that occur during periods of rapid temperature change within the doorbell **130**, thereby advantageously reducing the frequency of false positive alerts.

With reference to FIG. **25**, at block **B630** a temperature change within and/or near the doorbell **130** during an interval is measured. The temperature change may be measured with rate or more temperature sensors, such as a temperature sensor (not shown) associated with the battery **166**, and/or the temperature sensor **153** of the bracket PCB **149**. Then, at block **B632**, the rate of temperature change during the measured interval is calculated. In some embodi-

ments, the microcontroller **163** may calculate the rate of temperature change. Then, at block **B634**, the calculated rate of temperature change is compared with a threshold value. In some embodiments, the microcontroller **163** may make the comparison. In one non-limiting example, the threshold value used in the comparison may be  $1^{\circ}$  C./min. If the calculated rate of temperature change is greater than the threshold value, then at block **B636**, any output signals from the PIR sensors **144** that occurred during the measured interval are ignored because they are likely to be unreliable. If, however, the calculated rate of temperature change is not greater than the threshold value, then at block **B638** any output signals from the PIR sensors **144** that occurred during the measured interval are not ignored.

The foregoing process advantageously filters out signals from the PIR sensors **144** that are likely to be unreliable because they occurred during periods of rapid temperature change within the doorbell **130** when the PIR sensors **144** may have been unstable. This process thus advantageously results in fewer alert signals being sent to the user, thereby reducing the frequency of false positive alerts.

#### Visitor Approaching vs. Visitor Departing

Another aspect of the present embodiments includes the realization that unwanted alert signals may be generated by an A/V recording and communication device, such as a doorbell, when a home occupant walks out the front door. As further described below, processes according to the present embodiments solve this problem by determining whether a moving object is moving toward or away from the doorbell (or other A/V recording and communication device), and generating alerts only in those instances when it is determined that the moving object is moving toward the doorbell, thereby reducing the frequency of unwanted alerts to the user.

FIG. **26** illustrates a process for determining whether a visitor within the field of view of the doorbell **130** is moving toward, or away from the doorbell **130**, according to the present embodiments. Generally, if a visitor is moving toward the doorbell **130**, the magnitude of the output signal generated by the PIR sensors **144** increase as the visitor moves closer and closer to the doorbell **130**. Conversely, if a visitor is moving away from the doorbell **130**, the magnitude of the output signal generated by the sensors **144** will decrease as the visitor moves farther and farther away from the doorbell **130**. Determining whether a visitor is moving toward or away from the doorbell **130** can reduce unwanted alert signals to the user. For example, a user may not want to receive an alert when a home occupant walks out the front door. Thus, if it can be determined that a moving object is moving away from the doorbell **130**, then an alert may not be generated in those instances, thereby reducing the frequency of unwanted alerts to the user.

With reference to FIG. **26**, at block **B650**, one or more of the PIR sensors **144** detects a moving object within the field of view of the doorbell **130** and generates an output signal. At block **B652**, the microcontroller **163** samples the output signal over a plurality of sampling intervals and analyzes the information in each of the samples. The number of sampling intervals may be a preset number, or may be whatever number of samples is needed to make a positive determination that there is motion within the field of view of the doorbell **130**. At block **B654**, the microcontroller **163** calculates the magnitude of the output signal during each of the sampling intervals. Then, at block **B656**, the microcontroller **163** determines if the magnitude of the output signal is increasing or decreasing over the course of the sampling intervals. If the magnitude of the output signal is increasing,

then, at block B658, the microcontroller 163 determines that the moving object is moving toward the doorbell 130. If, however, the magnitude of the output signal is decreasing, then, at block B660, the microcontroller 163 determines that the moving object is moving away from the doorbell 130. While not shown in FIG. 26, if it is determined that the moving object is moving away from the doorbell 130, in some embodiments the doorbell 130 may not generate an alert for the user.

FIG. 27 illustrates another process for determining whether a visitor within the field of view of the doorbell 130 is moving toward or away from the doorbell 130, according to the present embodiments. Generally, if a visitor is moving, toward the doorbell 130, the number of the PIR sensors 144 that detect the visitor will increase over time as the visitor moves closer and closer to the doorbell 130. Conversely, if a visitor is moving away from the doorbell 130, the number of the PIR sensors 144 that detect the visitor will decrease over time as the visitor moves farther and farther away from the doorbell 130. For example, with reference to FIG. 11, a visitor approaching from just outside one of the Zones 1-5 will first be detected by just one of the PIR sensors 144-1, 144-2, 144-3, but by the time the visitor reaches the doorbell 130 he or she will be detected by all three of the PIR sensors 144-1, 144-2, 144-3. Conversely, if a visitor begins from a point very close to the doorbell 130 and moves away from the doorbell 130, he or she will first be detected by all three of the PIR sensors 144-1, 144-2, 144-3, and then by fewer and fewer of the PIR sensors 144-1, 144-2, 144-3 as he or she moves farther and farther away. Determining whether a visitor is moving toward or away from the doorbell 130 can reduce unwanted alert signals to the user. For example, a user may not want to receive an alert when a home occupant walks out the front door. Thus, if it can be determined that a moving object is moving away from the doorbell 130, then an alert may not be generated in those instances, thereby reducing the frequency of unwanted alerts to the user.

With reference to FIG. 27, at block B670, at least one of the PIR sensors 144 detects, at a first time, a moving object within the field of view of the doorbell 130 and generates an output signal. At block B672, at least one of the PIR sensors 144 detects, at a second time, the moving object within the field of view of the doorbell 130, and generates an output signal. At block B674, the microcontroller 163 determines whether the number of PIR sensors 144 that detected the moving object at the first time is greater than or less than the number of PIR sensors 144 that detected the moving object at the second time. If the number of PIR sensors 144 that detected the moving object at to first time is greater than the number of PIR sensors 144 that detected the moving object at the second time, then, at block B676, the microcontroller 163 determines that the moving object is moving away from the doorbell 130. If, however, the number of PIR sensors 144 that detected the moving object at the first time is less than the number of PIR sensors 144 that detected the moving object at the second time, then, at block B678, the microcontroller 163 determines that the moving object is moving toward the doorbell 130. While not shown in FIG. 27, if it is determined that the moving object is moving away from the doorbell 130, in some embodiments the doorbell 130 may not generate an alert for the user.

In certain embodiments, the processes of FIGS. 26 and 27 may be combined in order to increase the accuracy of the determination of whether the moving object is moving toward or away from the doorbell 130. For example, if it is determined that the magnitude of the output signal from the

PIR sensors 144 is increasing, which is indicative of the moving object moving toward the doorbell 130, then it may also be determined whether the number of the PIR sensors 144 that detect the moving object is increasing, which it should be if the moving object is in fact moving toward the doorbell 130. Conversely, if it is determined that the number of the PIR sensors 144 that detect the moving object is increasing, which is indicative of the moving object moving toward the doorbell 130, then it may also be determined whether the magnitude of the output signal from the PIR sensors 144 is increasing, which it should be if the moving object is in fact moving toward the doorbell 130. If, in either case, the determinations (magnitude of output signal vs. number of PIR sensors) contradict one another, the process may loop back and repeat one or more steps before making a final determination whether the moving object is moving toward or away from the doorbell 130.

FIG. 28 illustrates three different thresholds that may be used in one or more motion detection algorithms, according to various aspects of the present disclosure. One threshold, which is labeled Sample\_Th in FIG. 28 and represented by the lower dashed line 690, is a minimum magnitude that an output signal from the PIR sensors 144 must measure in order to be considered in any of the motion detection algorithms of the present embodiments. In other words, the present motion detection algorithms may ignore any output signals from the PIR sensors 144 that are below the Sample\_Th threshold.

Another threshold, which is labeled Motion\_Sample\_Th in FIG. 28 and represented by the upper dashed line 692, is a minimum magnitude that an output signal from the PIR sensors 144 must measure in order to be considered indicative of motion. In other words, output signals from the PIR sensors 144 that are above the Sample\_Th threshold, but below the Motion\_Sample\_Th threshold, are considered by the motion detection algorithms of the present embodiments to be not necessarily indicative of motion, whereas output signals from the PIR sensors 144 that are above the Motion\_Sample\_Th threshold are considered by the motion detection algorithms of the present embodiments to be indicative of motion.

Another threshold, which is labeled Motion\_Detect\_Th in FIG. 28 and represented by the bracket 694, is a minimum number of sampling intervals 696 of the output signal from the PIR sensors 144 in a given window of time that must be indicative of motion in order to determine that motion is actually present in the field of view of the doorbell 130. For example, if a time window of 2 seconds is considered, and if the value of Motion\_Detect\_Th is set to 12, then the microcontroller 163 will generate a motion alert if at least 12 sampling intervals 696 during the 2 second window are above the Motion\_Sample\_Th threshold. In some embodiments, the value of Motion\_Detect\_Th may be preset.

In certain embodiments, samples of the output signal from the PIR sensors 144 that fall between the Sample\_Th threshold and the Motion\_Sample\_Th threshold may be considered in determining whether motion is actually happening in the field of view of the doorbell 130. For example, some moving objects, such as objects that are moving very slowly, may only generate output signals from the PIR sensors 144 that are above the Motion\_Sample\_Th threshold for a short time. If these output signals remain above the Motion\_Sample\_Th threshold for such a short time that not enough samples can be taken to meet the Motion\_Detect\_Th threshold, then the output signals above the Motion\_Sample\_Th threshold may not be counted as actual motion, even though motion is actually happening in the field of view of

the doorbell **130**. In such situations, some of the present embodiments may consider the output signals from the PIR sensors **144** that fall between the Sample\_Th threshold and the Motion\_Sample\_Th threshold in determining whether motion is actually happening in the field of view of the doorbell **130**.

The present embodiments have been described with reference to the doorbell **130** illustrated in FIGS. **2-12**. It should be understood, however, that the present embodiments are equally applicable to any A/V recording, and communication device that is capable of recording video footage and/or audio and transmitting the recorded video footage and/or audio via a wireless and/or wired connection. In certain embodiments, for example, the A/V recording and communication device may not be a doorbell, but may be, for example, a wireless A/V recording and communication security camera. An example A/V recording and communication security camera may include substantially all of the structure and functionality of the doorbell **130**, but without the front button **133**, the button actuator, and/or the light pipe **136**. An example A/V recording and communication security camera may further omit other components, such as, for example, the bracket PCB **149** and its components.

FIG. **29** is a functional block diagram of a client device **850** on which the present embodiments may be implemented according to various aspects of the present disclosure. The user's client device **114** described with reference to FIG. **1** may include some or all of the components and/or functionality of the client device **850**. The client device **850** may comprise, for example, a smartphone.

With reference to FIG. **29**, the client device **850** includes a processor **852**, a memory **854**, a user interface **856**, a communication module **858**, and a dataport **860**. These components are communicatively coupled together by an interconnect bus **862**. The processor **852** may include any processor used in smartphones and/or portable computing devices, such as an ARM processor (a processor based on the RISC (reduced instruction set computer) architecture developed by Advanced RISC Machines (ARM)). In some embodiments, the processor **852** may include one or more other processors, such as one or more conventional microprocessors, and/or one or more supplementary co-processors, such as math co-processors.

The memory **854** may include both operating memory, such as random access memory (RAM), as well as data storage, such as read-only memory (ROM), hard drives, flash memory, or any other suitable memory/storage element. The memory **854** may include removable memory elements, such as a CompactFlash card, a MultiMediaCard (MMC), and/or a Secure Digital (SD) card. In some embodiments, the memory **854** may comprise a combination of magnetic, optical, and/or semiconductor memory, and may include, for example, RAM, ROM, flash drive, and/or a hard disk or drive. The processor **852** and the memory **854** each may be, for example, located entirely within a single device, or may be connected to each other by a communication medium, such as a USB port, a serial port cable, a coaxial cable, an Ethernet-type cable, a telephone line, a radio frequency transceiver, or other similar wireless or wired medium or combination of the foregoing. For example, the processor **852** may be connected to the memory **854** via the dataport **860**.

The user interface **856** may include any user interface or presentation elements suitable for a smartphone and/or a portable computing device, such as a keypad, a display screen, a touchscreen, a microphone, and a speaker. The communication module **858** is configured to handle com-

munication links between the client device **850** and other, external devices or receivers, and to route incoming/outgoing data appropriately. For example, inbound data from the dataport **860** may be routed through the communication module **858** before being directed to the processor **852**, and outbound data from the processor **852** may be routed through the communication module **858** before being directed to the dataport **860**. The communication module **858** may include one or more transceiver modules capable of transmitting and receiving data, and using, for example, one or more protocols and/or technologies, such as GSM, UMTS (3GSM), IS-95 (CDMA one), IS-2000 (CDMA 2000), LTE, FDMA, TDMA, W-CDMA, CDMA, OFDMA, Wi-Fi, WiMAX, or any other protocol and/or technology.

The dataport **860** may be any type of connector used for physically interfacing with a smartphone and/or a portable computing device, such as a mini-USB port or an IPHONE®/IPOD® 30-pin connector or LIGHTNING® connector. In other embodiments, the dataport **860** may include multiple communication channels for simultaneous communication with, for example, other processors, servers, and/or client terminals.

The memory **854** may store instructions for communicating with other systems, such as a computer. The memory **854** may store, for example, a program (e.g., computer program code) adapted to direct the processor **852** in accordance with the present embodiments. The instructions also may include program elements, such as an operating system. While execution of sequences of instructions in the program causes the processor **852** to perform the process steps described herein, hard wired circuitry may be used in place of, or in combination with, software/firmware instructions for implementation of the processes of the present embodiments. Thus, the present embodiments are not limited to any specific combination of hardware and software.

FIG. **30** is a functional block diagram of a general-purpose computing system on which the present embodiments may be implemented according to various aspects of the present disclosure. The computer system **900** may execute at least some of the operations described above. The computer system **900** may be embodied in at least one of a personal computer (also referred to as a desktop computer) **900A**, a portable computer (also referred to as a laptop or notebook computer) **900B**, and/or a server **900C**. A server is a computer program and/or a machine that waits for requests from other machines or software (clients) and responds to them. A server typically processes data. The purpose of a server is to share data and/or hardware and/or software resources among clients. This architecture is called the client-server model. The clients may run on the same computer or may connect to the server over a network. Examples of computing servers include database servers, file servers, mail servers, print servers, web servers, game servers, and application servers. The term server may be construed broadly to include any computerized process that shares a resource to one or more client processes.

The computer system **900** may include at least one processor **910**, memory **920**, at least one storage device **930**, and input/output (I/O) devices **940**. Some or all of the components **910**, **920**, **930**, **940** may be interconnected via a system bus **950**. The processor **910** may be single- or multi-threaded and may have one or more cores. The processor **910** may execute instructions, such as those stored in the memory **920** and/or in the storage device **930**. Information may be received and output using one or more I/O devices **940**.

The memory 920 may store information, and may be a computer-readable medium, such as volatile or non-volatile memory. The storage device(s) 930 may provide storage for the system 900, and may be a computer-readable medium. In various aspects, the storage device(s) 930 may be a flash

memory device, a hard disk device, an optical disk device, a tape device, or any other type of storage device. The I/O devices 940 may provide input/output operations for the system 900. The I/O devices 940 may include a keyboard, a pointing device, and/or a microphone. The I/O devices 940 may further include a display unit for displaying graphical user interfaces, a speaker, and/or a printer. External data may be stored in one or more accessible external databases 960.

The features of the present embodiments described herein may be implemented in digital electronic circuitry, and/or in computer hardware, firmware, software, and/or in combinations thereof. Features of the present embodiments may be implemented in a computer program product tangibly embodied in an information carrier, such as a machine-readable storage device, and/or in a propagated signal, for execution by a programmable processor. Embodiments of the present method steps may be performed by a programmable processor executing a program of instructions to perform functions of the described implementations by operating on input data and generating output.

The features of the present embodiments described herein may be implemented in one or more computer programs that are executable on a programmable system including at least one programmable processor coupled to receive data and/or instructions from, and to transmit data and/or instructions to, a data storage system, at least one input device, and at least one output device. A computer program may include a set of instructions that may be used, directly or indirectly, in a computer to perform a certain activity or bring about a certain result. A computer program may be written in any form of programming language, including compiled or interpreted languages, and it may be deployed in any form, including as a stand-alone program or as a module, component, subroutine, or other unit suitable for use in a computing environment.

Suitable processors for the execution of a program of instructions may include, for example, both general and special purpose processors, and/or the sole processor or one of multiple processors of any kind of computer. Generally, a processor may receive instructions and/or data from a read only memory (ROM), or a random access memory (RAM), or both. Such a computer may include a processor for executing instructions and one or more memories for storing instructions and/or data.

Generally, a computer may also include, or be operatively coupled to communicate with, one or more mass storage devices for storing data files. Such devices include magnetic disks, such as internal hard disks and/or removable disks, magneto-optical disks, and/or optical disks. Storage devices suitable for tangibly embodying computer program instructions and/or data may include all forms of non-volatile memory, including for example semiconductor memory devices, such as EPROM, EEPROM, and flash memory devices, magnetic disks such as internal hard disks and removable disks, magneto-optical disks, and CD-ROM and DVD-ROM disks. The processor and the memory may be supplemented by, or incorporated in, one or more ASICs (application-specific integrated circuits).

To provide for interaction with a user, the features of the present embodiments may be implemented on a computer having a display device, such as an LCD (liquid crystal

display) monitor, for displaying information to the user. The computer may further include a keyboard, a pointing device, such as a mouse or a trackball, and/or a touchscreen by which the user may provide input to the computer.

The features of the present embodiments may be implemented in a computer system that includes a back-end component, such as a data server, and/or that includes a middleware component, such as an application server or an Internet server, and/or that includes a front-end component, such as a client computer having a graphical user interface (GUI) and/or an Internet browser, or any combination of these. The components of the system may be connected by any form or medium of digital data communication, such as a communication network. Examples of communication networks may include, for example, a LAN (local area network), a WAN (wide area network), and/or the computers and networks forming the Internet.

The computer system may include clients and servers. A client and server may be remote from each other and interact through a network, such as those described herein. The relationship of client and server may arise by virtue of computer programs running on the respective computers and having a client-server relationship to each other.

The above description presents the best mode contemplated for carrying out the present embodiments, and of the manner and process of practicing them, in such full, clear, concise, and exact terms as to enable any person skilled in the art to which they pertain to practice these embodiments. The present embodiments are, however, susceptible to modifications and alternate constructions from those discussed above that are fully equivalent. Consequently, the present invention is not limited to the particular embodiments disclosed. On the contrary, the present invention covers all modifications and alternate constructions coming within the spirit and scope of the present disclosure. For example, the steps in the processes described herein need not be performed in the same order as they have been presented, and may be performed in any order(s). Further, steps that have been presented as being performed separately may in alternative embodiments be performed concurrently. Likewise, steps that have been presented as being performed concurrently may in alternative embodiments be performed separately.

What is claimed is:

1. A method for an audio/video (A/V) recording and communication device, including a motion sensor, the method comprising:

gathering, by the motion sensor, information within a field of view of the A/V recording and communication device and generating an output signal;  
 sampling the output signal from the motion sensor during a first sampling interval;  
 calculating a first magnitude of the output signal during the first sampling interval;  
 sampling the output signal from the motion sensor during a second sampling interval;  
 calculating a second magnitude of the output signal during the second sampling interval;  
 calculating a difference between the first magnitude and the second magnitude;  
 comparing the difference between the first magnitude and the second magnitude to a threshold value; and  
 upon determining that the difference between the first magnitude and the second magnitude is greater than the threshold value, refraining from generating an alert signal.

2. The method of claim 1, wherein the sampling the output signal during the first sampling interval, the calculating the first magnitude, the sampling the output signal during the second sampling interval, the calculating the second magnitude, the calculating the difference, the comparing the difference, and the refraining are performed by one or more processors of the A/V recording and communication device.

3. The method of claim 1, wherein the motion sensor comprises at least one passive infrared (PIR) sensor and the gathering the information within the field of view of the A/V recording and communication device comprises receiving infrared radiation from within the field of view of the A/V recording and communication device.

4. The method of claim 1, wherein the calculating the difference between the first magnitude and the second magnitude determines a rate of change of the output signal from the motion sensor.

5. The method of claim 1, wherein the threshold value comprises a threshold rate of change.

6. The method of claim 1, further comprising determining a peak magnitude of the output signal and comparing the peak magnitude to a threshold peak magnitude.

7. An audio/video (A/V) recording and communication device, comprising:

- one or more processors;
- a motion sensor configured to gather information from within a field of view of the A/V recording and communication device and to generate an output signal based at least in part on the gathered information; and memory storing instructions that, when executed by the one or more processors, cause the one or more processors to perform operations comprising:
  - sampling the output signal from the motion sensor during a first sampling interval;
  - calculating a first magnitude of the output signal during the first sampling interval;
  - sampling the output signal from the motion sensor during a second sampling interval;
  - calculating a second magnitude of the output signal during the second sampling interval;
  - calculating a difference between the first magnitude and the second magnitude;
  - comparing the difference between the first magnitude and the second magnitude to a threshold value; and

suppressing transmission of an alert signal when the difference between the first magnitude and the second magnitude is greater than the threshold value.

8. The A/V recording and communication device of claim 7, wherein the motion sensor comprises at least one passive infrared (PIR) sensor.

9. The A/V recording and communication device of claim 7, wherein the calculating the difference between the first magnitude and the second magnitude determines a rate of change of the output signal from the motion sensor.

10. The A/V recording and communication device of claim 7, wherein the threshold value comprises a threshold rate of change.

11. The A/V recording and communication device of claim 7, wherein the memory further stores instructions that, when executed by the one or more processors, cause the one or more processors to perform operations comprising:
 

- determining a peak magnitude of the output signal; and
- comparing the peak magnitude to a threshold peak magnitude.

12. An audio/video (A/V) recording and communication device, comprising:

- a motion sensor configured to generate an output signal based at least in part on gathering information in a field of view of the A/V recording and communication device; and
- one or more processors configure to:
  - determine a peak magnitude of the output signal;
  - compare the peak magnitude of the output signal to a threshold value; and
  - upon determining that the peak magnitude of the output signal is greater than the threshold value, refrain from transmitting an alert signal.

13. The A/V recording and communication device of claim 12, wherein the motion sensor comprises at least one passive infrared (PIR) sensor.

14. The A/V recording and communication device of claim 12, wherein the determining the peak magnitude of the output signal comprises sampling the output signal of the motion sensor over multiple sampling intervals.

15. The A/V recording and communication device of claim 12, wherein the processor is further configured to:
 

- determine a rate of change of the output signal from the motion sensor; and
- compare the rate of change to a threshold rate of change.

\* \* \* \* \*